



# Valuation

Aswath Damodaran

<http://www.damodaran.com>

For the valuations in this presentation, go to  
Seminars/ Presentations

## Some Initial Thoughts

" One hundred thousand lemmings cannot be wrong"

*Graffiti*

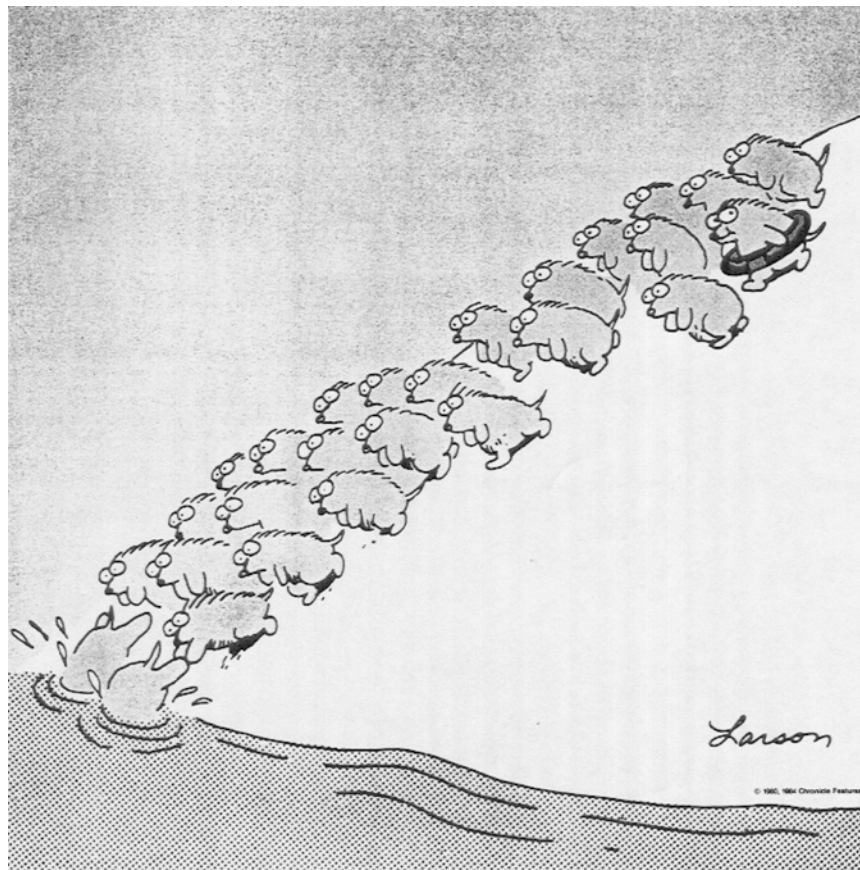

# Misconceptions about Valuation

---

- Myth 1: A valuation is an objective search for “true” value
  - Truth 1.1: All valuations are biased. The only questions are how much and in which direction.
  - Truth 1.2: The direction and magnitude of the bias in your valuation is directly proportional to who pays you and how much you are paid.
- Myth 2.: A good valuation provides a precise estimate of value
  - Truth 2.1: There are no precise valuations
  - Truth 2.2: The payoff to valuation is greatest when valuation is least precise.
- Myth 3: . The more quantitative a model, the better the valuation
  - Truth 3.1: One’s understanding of a valuation model is inversely proportional to the number of inputs required for the model.
  - Truth 3.2: Simpler valuation models do much better than complex ones.

## Approaches to Valuation

---

- **Discounted cashflow valuation**, relates the value of an asset to the present value of expected future cashflows on that asset.
- **Relative valuation**, estimates the value of an asset by looking at the pricing of 'comparable' assets relative to a common variable like earnings, cashflows, book value or sales.
- **Contingent claim valuation**, uses option pricing models to measure the value of assets that share option characteristics.

## Discounted Cash Flow Valuation

---

- **What is it:** In discounted cash flow valuation, the value of an asset is the present value of the expected cash flows on the asset.
- **Philosophical Basis:** Every asset has an intrinsic value that can be estimated, based upon its characteristics in terms of cash flows, growth and risk.
- **Information Needed:** To use discounted cash flow valuation, you need
  - to estimate the life of the asset
  - to estimate the cash flows during the life of the asset
  - to estimate the discount rate to apply to these cash flows to get present value
- **Market Inefficiency:** Markets are assumed to make mistakes in pricing assets across time, and are assumed to correct themselves over time, as new information comes out about assets.

## Discounted Cashflow Valuation: Basis for Approach

---

$$\text{Value of asset} = \frac{CF_1}{(1+r)^1} + \frac{CF_2}{(1+r)^2} + \frac{CF_3}{(1+r)^3} + \frac{CF_4}{(1+r)^4} \dots + \frac{CF_n}{(1+r)^n}$$

where  $CF_t$  is the expected cash flow in period  $t$ ,  $r$  is the discount rate appropriate given the riskiness of the cash flow and  $n$  is the life of the asset.

**Proposition 1: For an asset to have value, the expected cash flows have to be positive some time over the life of the asset.**

**Proposition 2: Assets that generate cash flows early in their life will be worth more than assets that generate cash flows later; the latter may however have greater growth and higher cash flows to compensate.**

# DCF Choices: Equity Valuation versus Firm Valuation

**Firm Valuation:** Value the entire business

Assets		Liabilities	
Existing Investments Generate cashflows today Includes long lived (fixed) and short-lived (working capital) assets	Assets in Place	Debt	Fixed Claim on cash flows Little or No role in management <i>Fixed Maturity</i> <i>Tax Deductible</i>
Expected Value that will be created by future investments	Growth Assets	Equity	Residual Claim on cash flows Significant Role in management <i>Perpetual Lives</i>

**Equity valuation:** Value just the equity claim in the business

# Equity Valuation

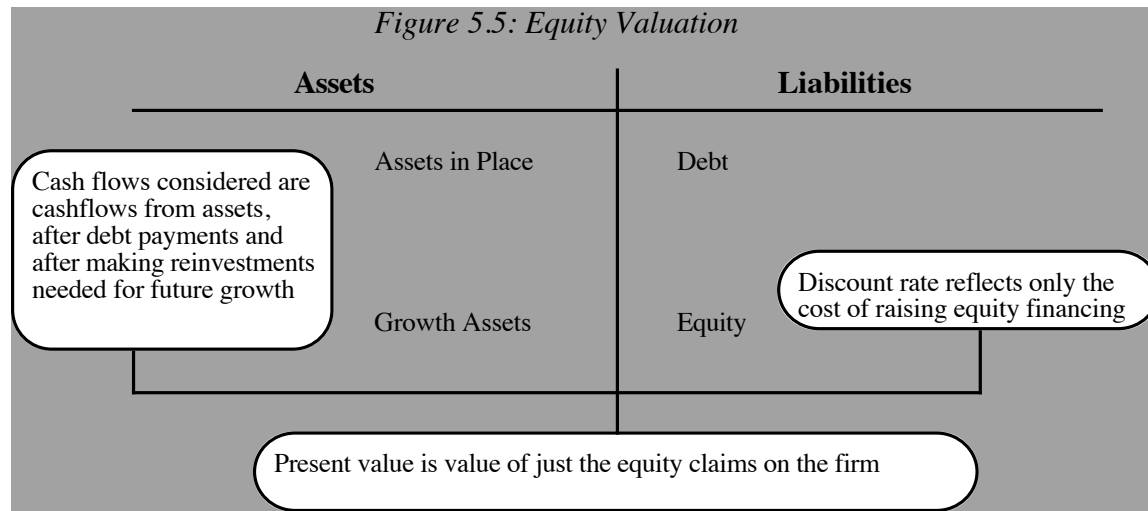



# Firm Valuation

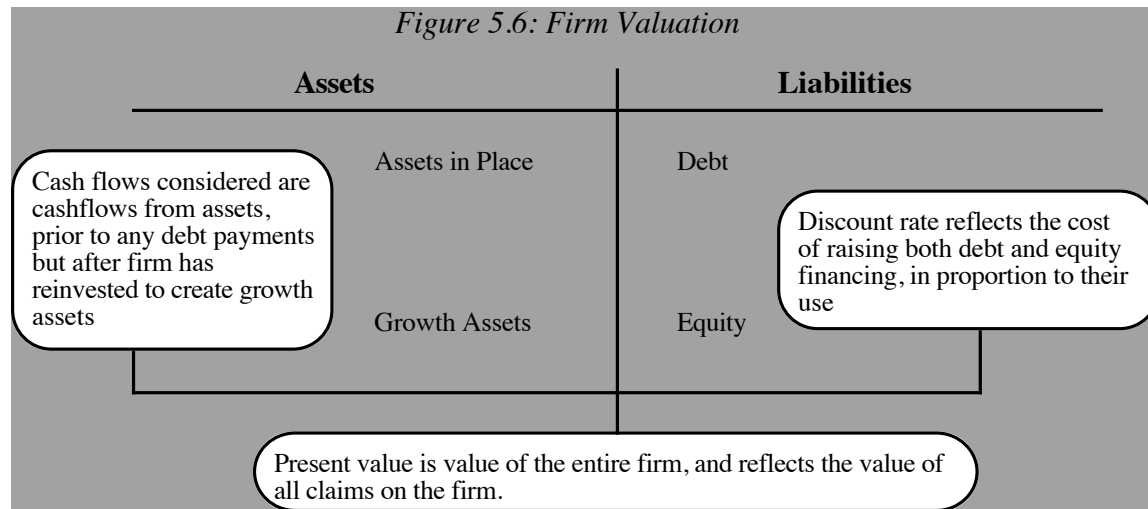

# DISCOUNTED CASHFLOW VALUATION

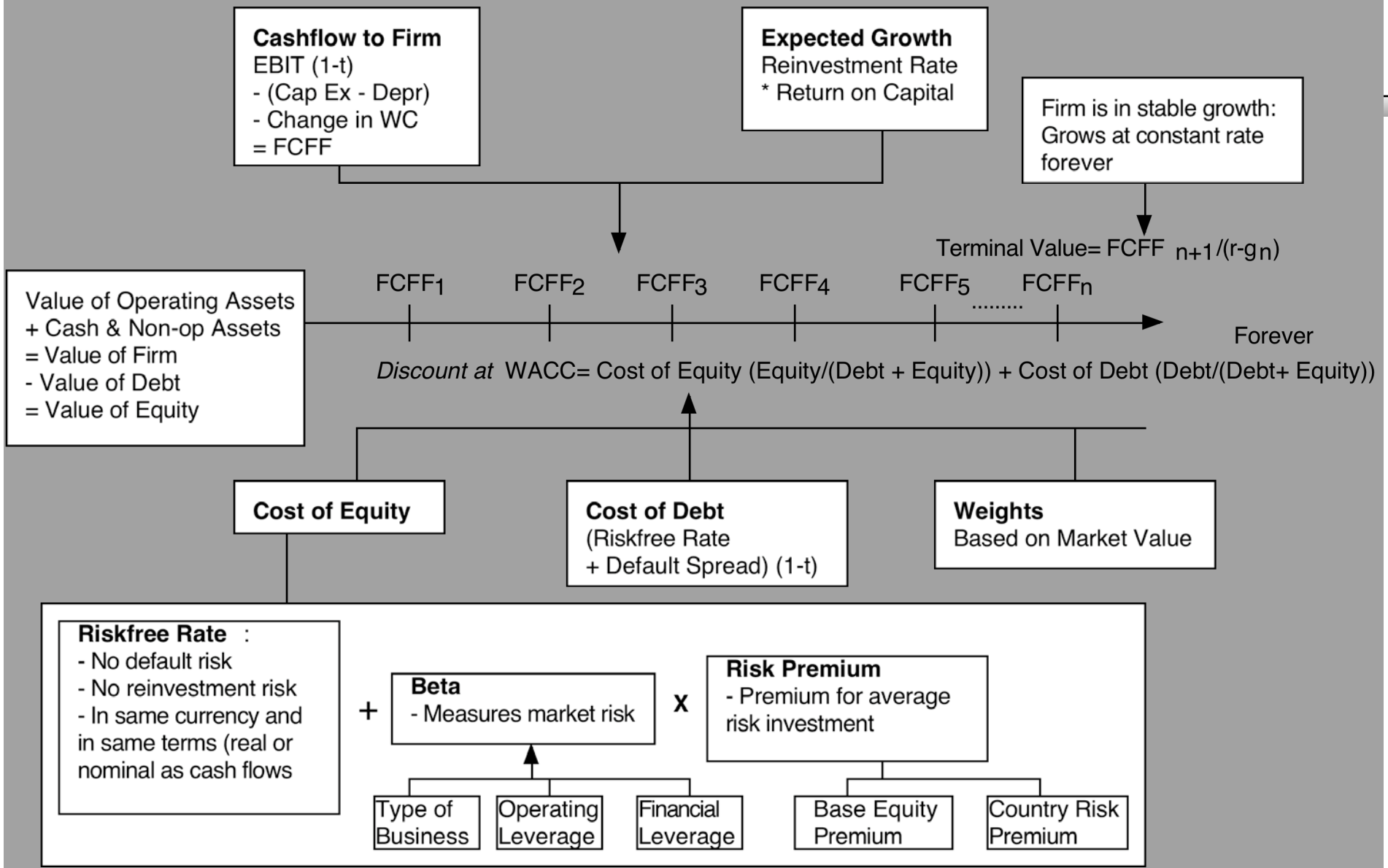

# Hyundai Heavy: Status Quo (Won)

**Current Cashflow to Firm**  
 EBIT(1-t) : 1,269 Billion Won  
 - Nt CpX 519  
 - Chg WC 135  
 = FCFF 615  
 Reinvestment Rate = 654/1269=51.5%  
 Return on capital = 1269/3390 =37.45%

Reinvestment Rate  
50%

Return on Capital  
30%

**Expected Growth in EBIT (1-t)**  
 $.50 \times .30 = .15$   
**15%**

Stable Growth  
 $g = 5\%$ ; Beta = 1.20;  
 Country Premium = 0.8%  
 Cost of capital = 9.42%  
 ROC = 9.42%  
 Reinvestment Rate =  $g/ROC = 5/9.42 = 53.1\%$

Terminal Value<sub>5</sub> =  $1258 \times (.0942 - .05) = 28,471$

Wn Cashflows

Year	1	2	3	4	5
EBIT (1-t)	1,460	1,679	1,931	2,220	2,553
- Reinvestment	730	839	965	1,110	1,277
FCFF	730	839	965	1,110	1,277

Term Yr  
 2,681  
 1,423  
 =1,258

Op. Assets 20,211  
 + Cash: 3,612  
 + Non-Op 3,937  
 - Debt 186  
 =Equity 27,574  
 -Options 0  
 Value/Share 362.82  
 (362,820 Won/Sh)

Discount at \$ Cost of Capital (WACC) = 11.3% (.993) + 4.75% (0.007) = 11.26%

**Cost of Equity**  
**11.30%**

**Cost of Debt**  
 $(5\% + 0.8\% + 0.75\%)(1 - .275)$   
 = 4.75%

**Weights**  
 E = 99.3% D = 0.7%

On June 1, 2008  
 Hyundai Heavy traded at  
 350,000 Won/share.

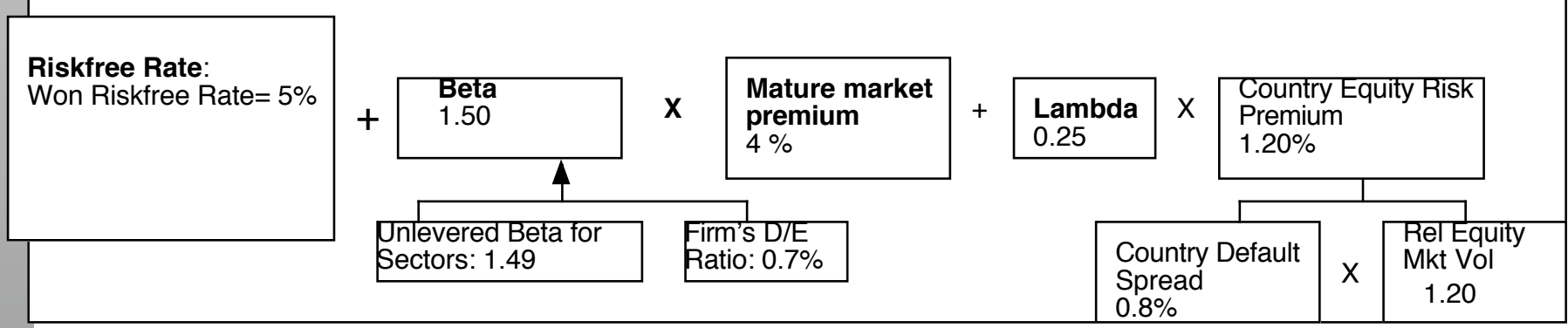

# Kristin's Kandy: Status Quo

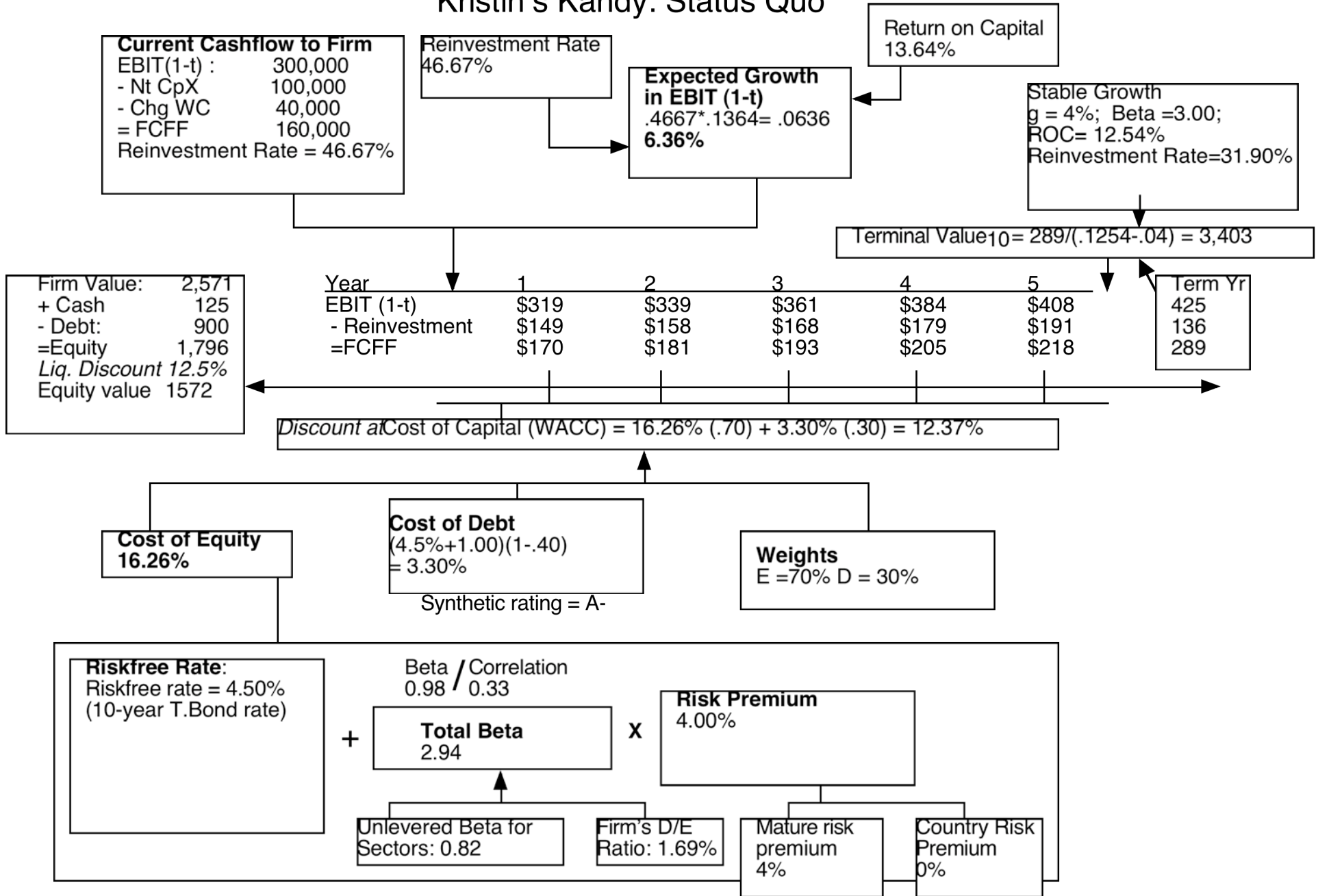

# Wells Fargo: Valuation on October 7, 2008

Assuming that Wells will have to increase its capital base by about 30% to reflect tighter regulatory concerns.  $(.1756/1.3 = .135)$

## Rationale for model

Why dividends? Because FCFE cannot be estimated

Why 2-stage? Because the expected growth rate in near term is higher than stable growth rate.

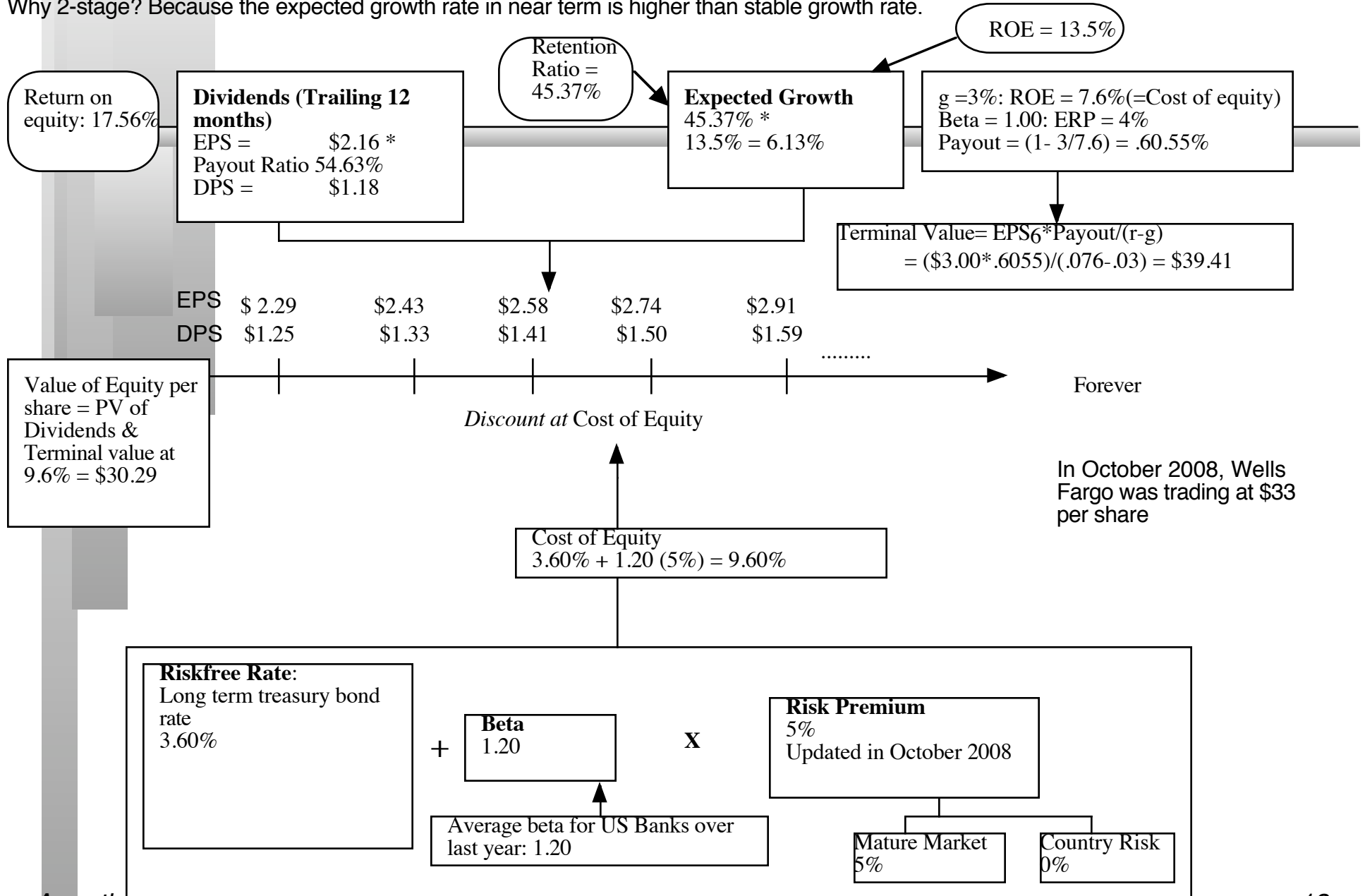

## Discounted Cash Flow Valuation: High Growth with Negative Earnings

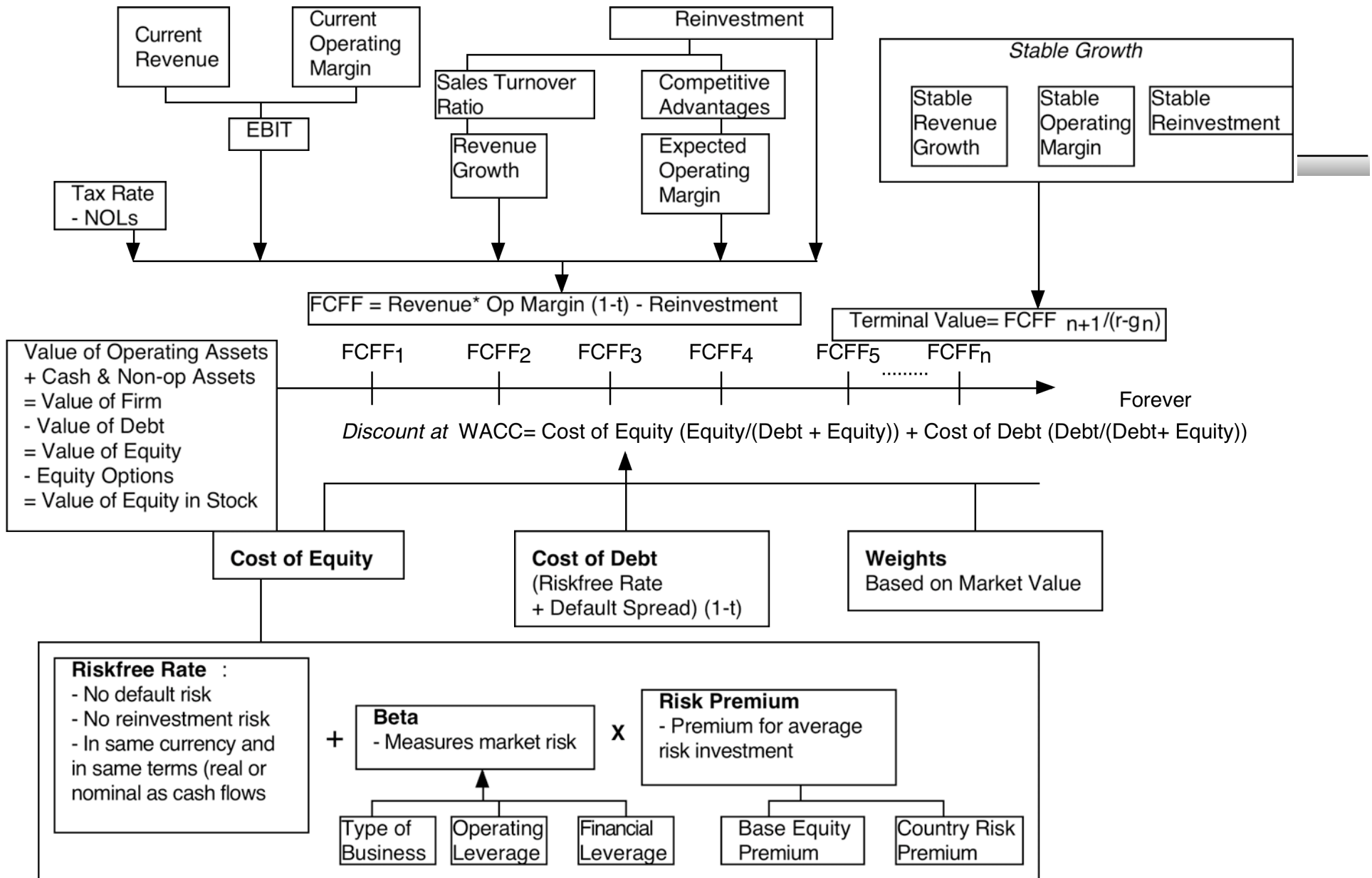

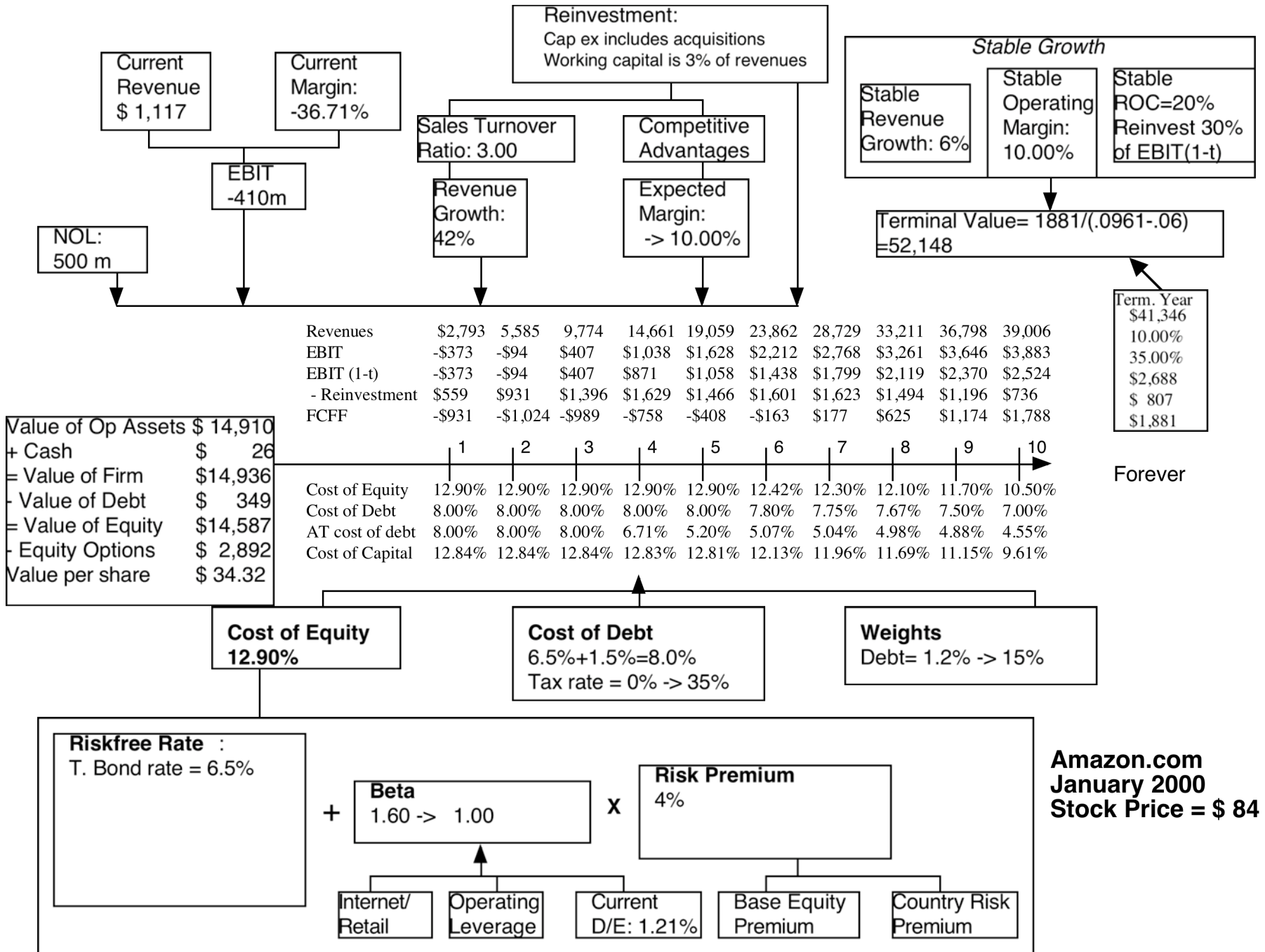



## I. Estimating Discount Rates



# Cost of Equity

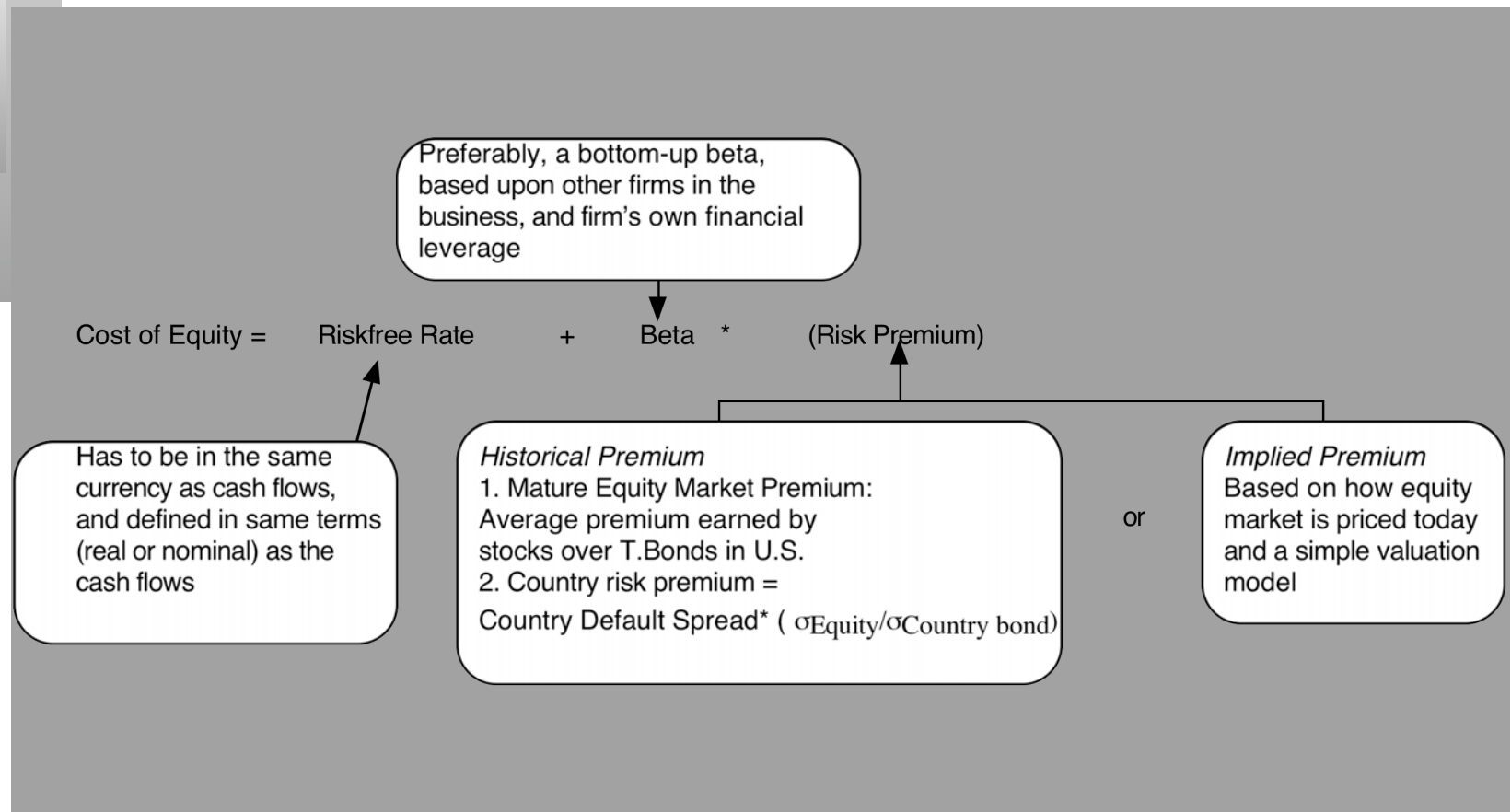

## A Riskfree Rate

---

**For a rate to be riskfree in valuation, it has to be long term, default free and currency matched (to the cash flows)**

■ Assume that you are valuing Hyundai Heavy Industries in Korean Won for a US institutional investor. Which of the following rates would you use as a riskfree rate?

- The rate on the US 10-year treasury bond (3.8%)
- The rate on the Korean (Won) 10-year government bond (5.8%)
- Other

How would your answer change if you were valuing Hyundai in US dollars for a Korean institutional investor?

## Riskfree Rates - Different Currencies

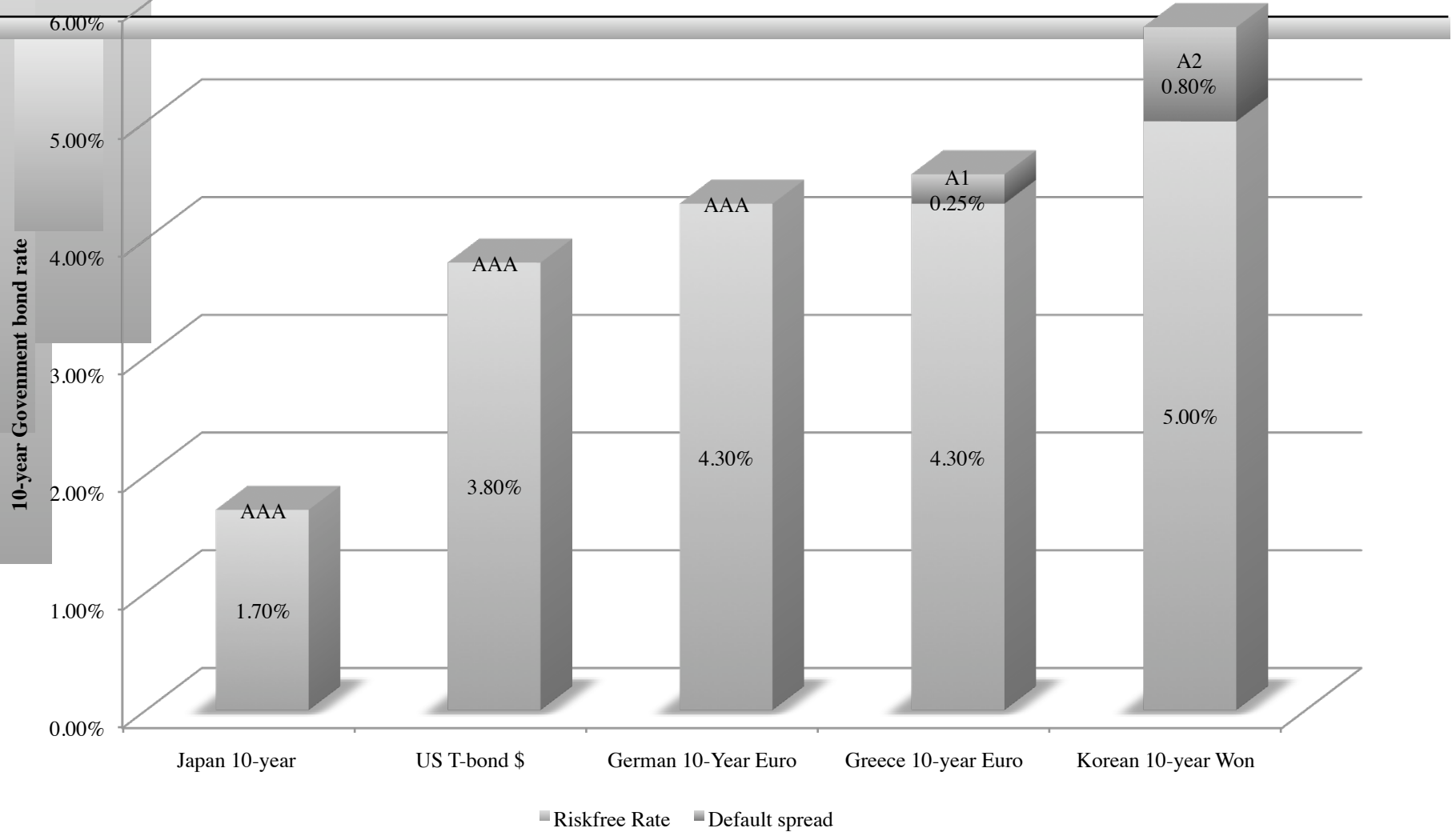

## Everyone uses historical premiums, but..

- The historical premium is the premium that stocks have historically earned over riskless securities.
- Practitioners never seem to agree on the premium; it is sensitive to
  - How far back you go in history...
  - Whether you use T.bill rates or T.Bond rates
  - Whether you use geometric or arithmetic averages.
- For instance, looking at the US:

Historical Period	<i>Arithmetic average</i>		<i>Geometric Average</i>	
	Stocks - T.Bills	Stocks - T.Bonds	Stocks - T.Bills	Stocks - T.Bonds
1928-2007	7.78%	6.42%	5.94%	4.79%
1967-2007	5.94%	4.33%	4.75%	3.50%
1997-2007	5.26%	2.68%	4.69%	2.34%

## Assessing Country Risk Using Currency Ratings: Asia

<i>Country</i>	<i>Local currency rating</i>	<i>Typical default spread</i>
Cambodia	B2	4.00%
China	A1	0.70%
Fiji Islands	Ba2	2.50%
Hong Kong	Aa2	0.50%
India	Ba2	2.50%
Indonesia	Ba3	3.00%
Japan	AAA	0.00%
Korea	A2	0.80%
Macao	Aa3	0.60%
Malaysia	A3	0.85%
Mongolia	B1	3.50%
Pakistan	B1	3.50%
Philippines	B1	3.50%
Singapore	Aaa	0.00%
Taiwan	Aa3	0.60%
Thailand	Baa1	1.00%
Vietnam	Ba3	3.00%

## Using Country Ratings to Estimate Equity Spreads

---

- Country ratings measure default risk. While default risk premiums and equity risk premiums are highly correlated, one would expect equity spreads to be higher than debt spreads.
  - One way to adjust the country spread upwards is to use information from the US market. In the US, the equity risk premium has been roughly twice the default spread on junk bonds.
  - Another is to multiply the bond spread by the relative volatility of stock and bond prices in that market. For example,
    - Standard Deviation in KOSPI = 18%
    - Standard Deviation in Korean government bond = 12%
    - Adjusted Equity Spread = 0.80% (18/12) = 1.20%

## From Country Risk Premiums to Corporate Risk premiums

---

- Approach 1: Assume that every company in the country is equally exposed to country risk. In this case,

$$E(\text{Return}) = \text{Riskfree Rate} + \text{Country ERP} + \text{Beta (US premium)}$$

- Approach 2: Assume that a company's exposure to country risk is similar to its exposure to other market risk.

$$E(\text{Return}) = \text{Riskfree Rate} + \text{Beta (US premium} + \text{Country ERP)}$$

- Approach 3: Treat country risk as a separate risk factor and allow firms to have different exposures to country risk (perhaps based upon the proportion of their revenues come from non-domestic sales)

$$E(\text{Return}) = \text{Riskfree Rate} + \beta (\text{US premium}) + \lambda (\text{Country ERP})$$

Country ERP: Additional country equity risk premium

## Estimating Company Exposure to Country Risk

- Different companies should be exposed to different degrees to country risk. For instance, a Korean firm that generates the bulk of its revenues in Western Europe and the US should be less exposed to country risk than one that generates all its business within Korea.

- The factor “ $\lambda$ ” measures the relative exposure of a firm to country risk. One simplistic solution would be to do the following:

$$\lambda = \% \text{ of revenues domestically}_{\text{firm}} / \% \text{ of revenues domestically}_{\text{avg firm}}$$

Consider two firms – Hyundai Heavy Industries and Megastudy, both Korean companies. The former gets about 20% of its revenues in Korea and the latter gets 100%. The average Korean firm gets about 80% of its revenues in Korea:

$$\lambda_{\text{Hyundai}} = 20\% / 80\% = 0.25$$

$$\lambda_{\text{Megastudy}} = 100\% / 80\% = 1.25$$

- There are two implications
  - A company’s risk exposure is determined by where it does business and not by where it is located
  - Firms might be able to actively manage their country risk exposures



## Estimating E(Return) for Hyundai Heavy Industries

- Assume that the beta for Hyundai Heavy is 1.50, and that the riskfree rate used is 5%. Also assume that the historical premium for the US (4.79%) is a reasonable estimate of a mature market risk premium.

- Approach 1: Assume that every company in the country is equally exposed to country risk. In this case,

$$E(\text{Return}) = 5\% + 1.2\% + 1.5 (4.79\%) = 13.39\%$$

- Approach 2: Assume that a company's exposure to country risk is similar to its exposure to other market risk.

$$E(\text{Return}) = 5\% + 1.5 (4.79\% + 1.2\%) = 13.99\%$$

- Approach 3: Treat country risk as a separate risk factor and allow firms to have different exposures to country risk (perhaps based upon the proportion of their revenues come from non-domestic sales)

$$E(\text{Return}) = 5\% + 1.5(4.79\%) + 0.25 (1.2\%) + 0.50 (2\%) = 13.49\%$$

Reflects revenues in Eastern Europe, China and the Rest of Asia

## An alternate view of ERP: Watch what I pay, not what I say..

- You can back out an equity risk premium from stock prices:

Year	Dividend Yield	Buybacks/Index	Yield
2001	1.37%	1.25%	2.62%
2002	1.81%	1.58%	3.39%
2003	1.61%	1.23%	2.84%
2004	1.57%	1.78%	3.35%
2005	1.79%	3.11%	4.90%
2006	1.77%	3.38%	5.15%
2007	1.89%	4.00%	5.89%
Average yield between 2001-2007 =			4.02%

Between 2001 and 2007 dividends and stock buybacks averaged 4.02% of the index each year.

Analysts expect earnings to grow 5% a year for the next 5 years. We will assume that dividends & buybacks will keep pace..  
Last year's cashflow (59.03) growing at 5% a year

After year 5, we will assume that earnings on the index will grow at 4.02%, the same rate as the entire economy (= riskfree rate).

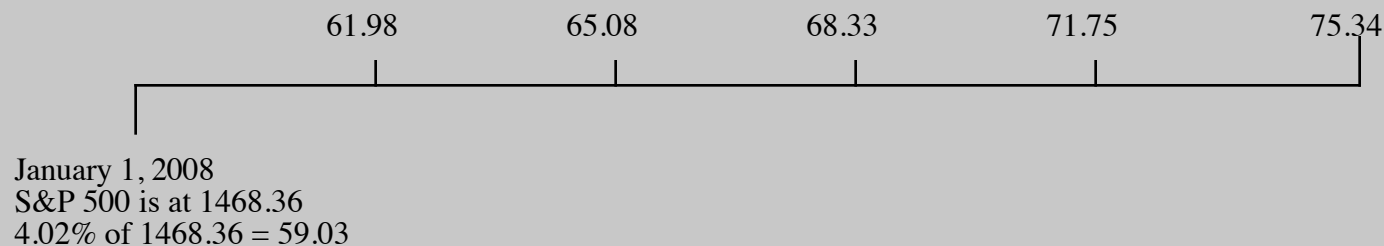

## Solving for the implied premium...

- If we know what investors paid for equities at the beginning of 2007 and we can estimate the expected cash flows from equities, we can solve for the rate of return that they expect to make (IRR):

$$1468.36 = \frac{61.98}{(1+r)} + \frac{65.08}{(1+r)^2} + \frac{68.33}{(1+r)^3} + \frac{71.75}{(1+r)^4} + \frac{75.34}{(1+r)^5} + \frac{75.35(1.0402)}{(r - .0402)(1+r)^5}$$

- Expected Return on Stocks = 8.39%
- Implied Equity Risk Premium = Expected Return on Stocks - T.Bond Rate  
= 8.39% - 4.02% = 4.37%

# Implied Premiums in the US

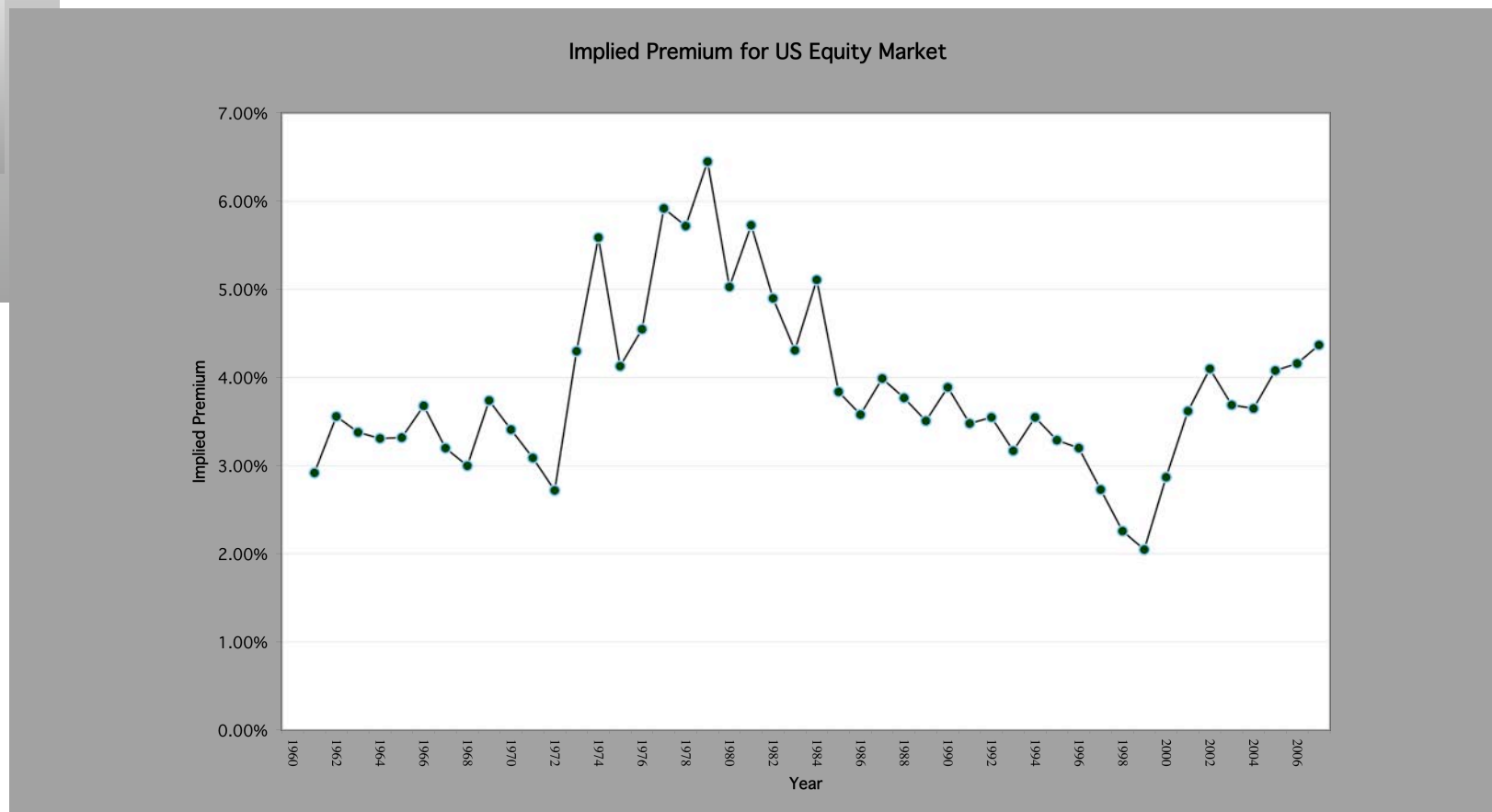

# Equity Risk Premiums in a Financial Crisis: ERP from 9/12 to 10/3

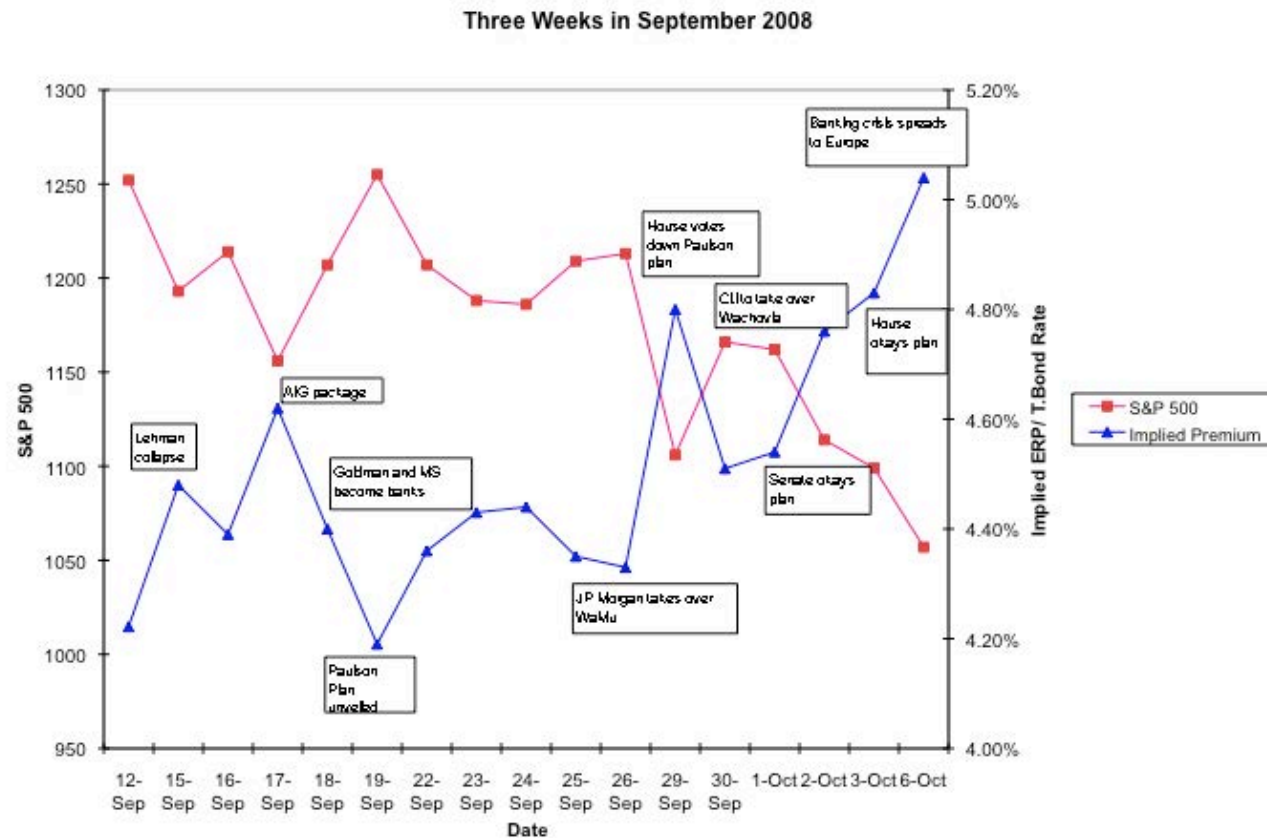

# Implied Premium versus RiskFree Rate

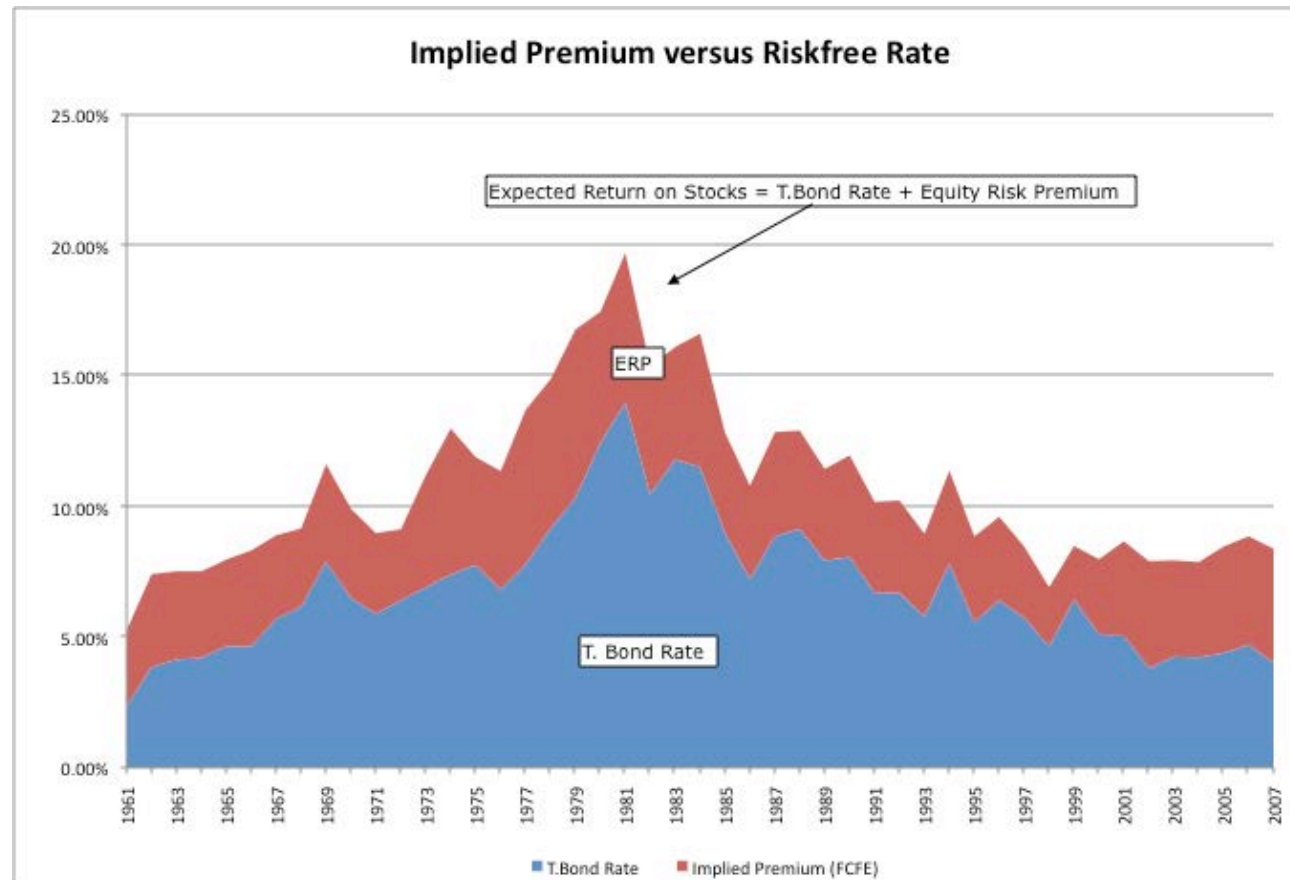

# Equity Risk Premiums and Bond Default Spreads

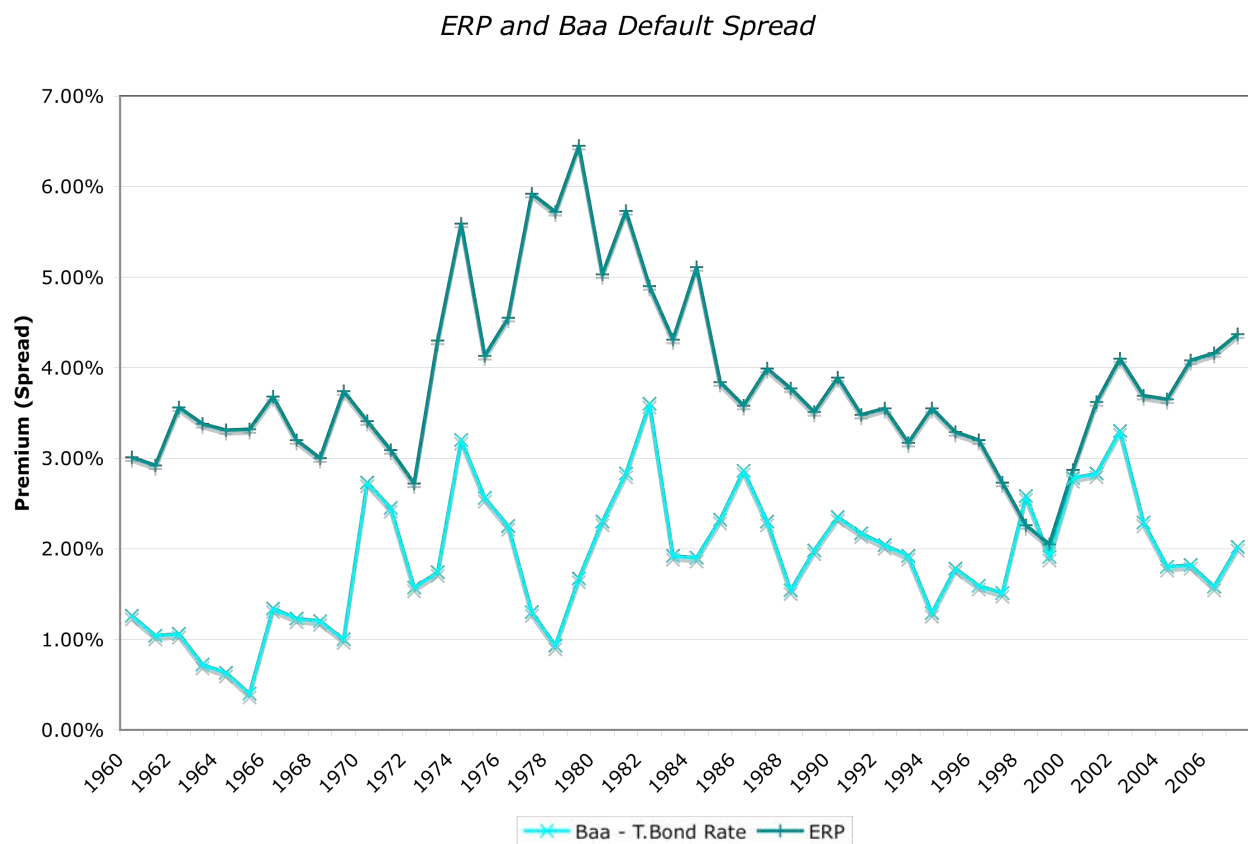

## Which equity risk premium should you use for the US?

---

- *Historical Risk Premium:* When you use the historical risk premium, you are assuming that premiums will revert back to a historical norm and that the time period that you are using is the right norm.
- *Current Implied Equity Risk premium:* You are assuming that the market is correct in the aggregate but makes mistakes on individual stocks. If you are required to be market neutral, this is the premium you should use. (What types of valuations require market neutrality?)
- *Average Implied Equity Risk premium:* The average implied equity risk premium between 1960-2007 in the United States is about 4%. You are assuming that the market is correct on average but not necessarily at a point in time.



## Implied Premium for KOSPI: May 30, 2008

---

- Level of the Index = 1825
- FCFE on the Index = 3.75% (Estimated FCFE for companies in index as % of market value of equity)
- Other parameters
  - Riskfree Rate = 5% (Won)
  - Expected Growth (in Won)
    - Next 5 years = 7.5% (Used expected growth rate in Earnings)
    - After year 5 = 5%
- Solving for the expected return:
  - Expected return on Equity = 9.39%
  - Implied Equity premium = 9.39% - 5% = 4.39%
- Effect on valuation
  - Hyundai's value @ historical premium (4%) + country (1.2%) : 350,000 Wn /share
  - Hyundai's value @ implied premium: 352,000 Wn/ share

## Estimating Beta

---

- The standard procedure for estimating betas is to regress stock returns ( $R_j$ ) against market returns ( $R_m$ ) -

$$R_j = a + b R_m$$

- where  $a$  is the intercept and  $b$  is the slope of the regression.
- The slope of the regression corresponds to the beta of the stock, and measures the riskiness of the stock.
- This beta has three problems:
  - It has high standard error
  - It reflects the firm's business mix over the period of the regression, not the current mix
  - It reflects the firm's average financial leverage over the period rather than the current leverage.

# Beta Estimation: Amazon

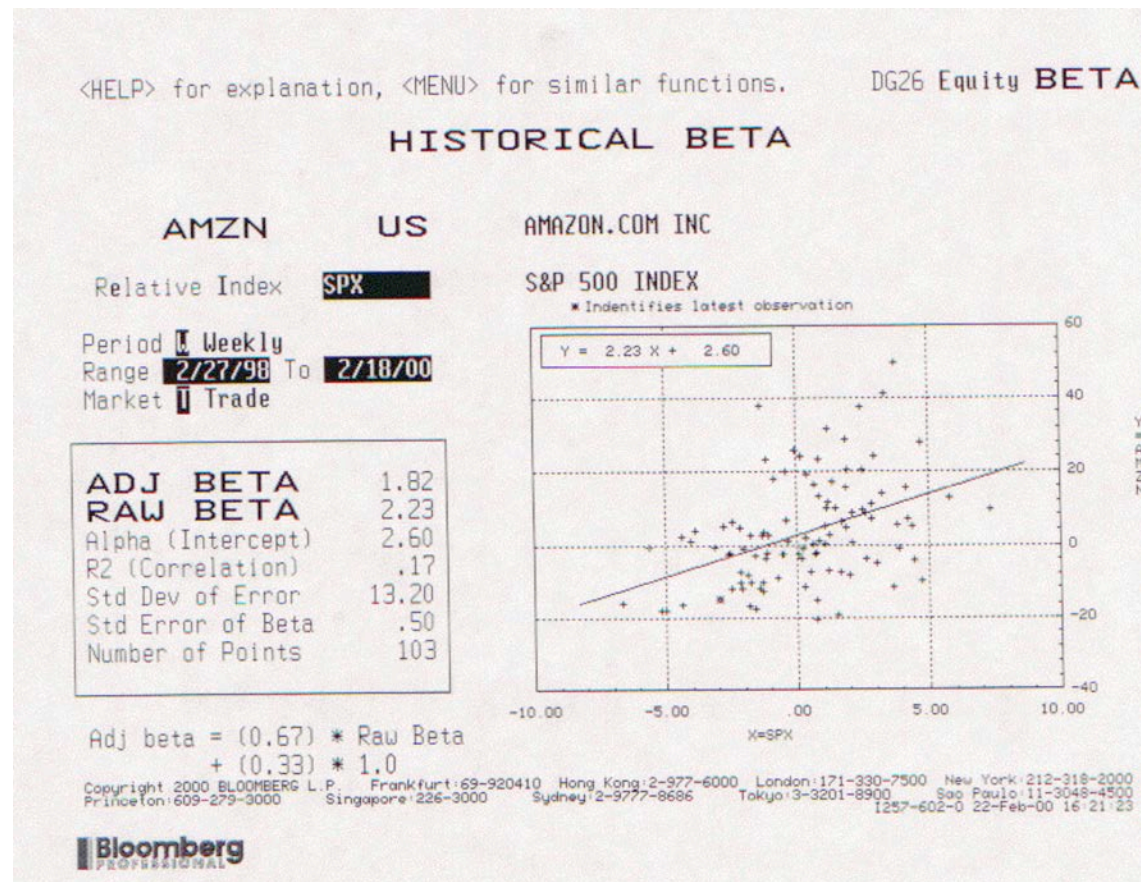

# Beta Estimation for Hyundai Heavy: The Index Effect

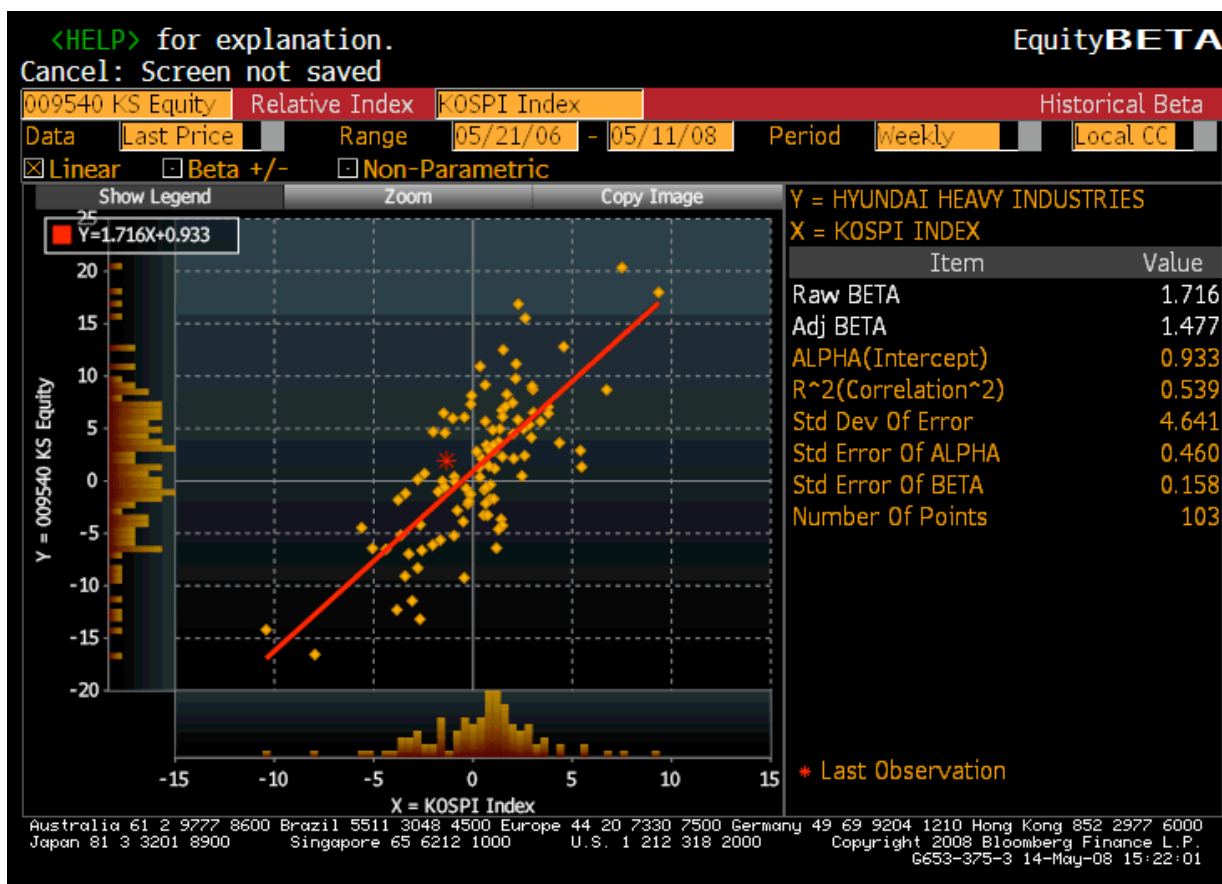

# Determinants of Betas

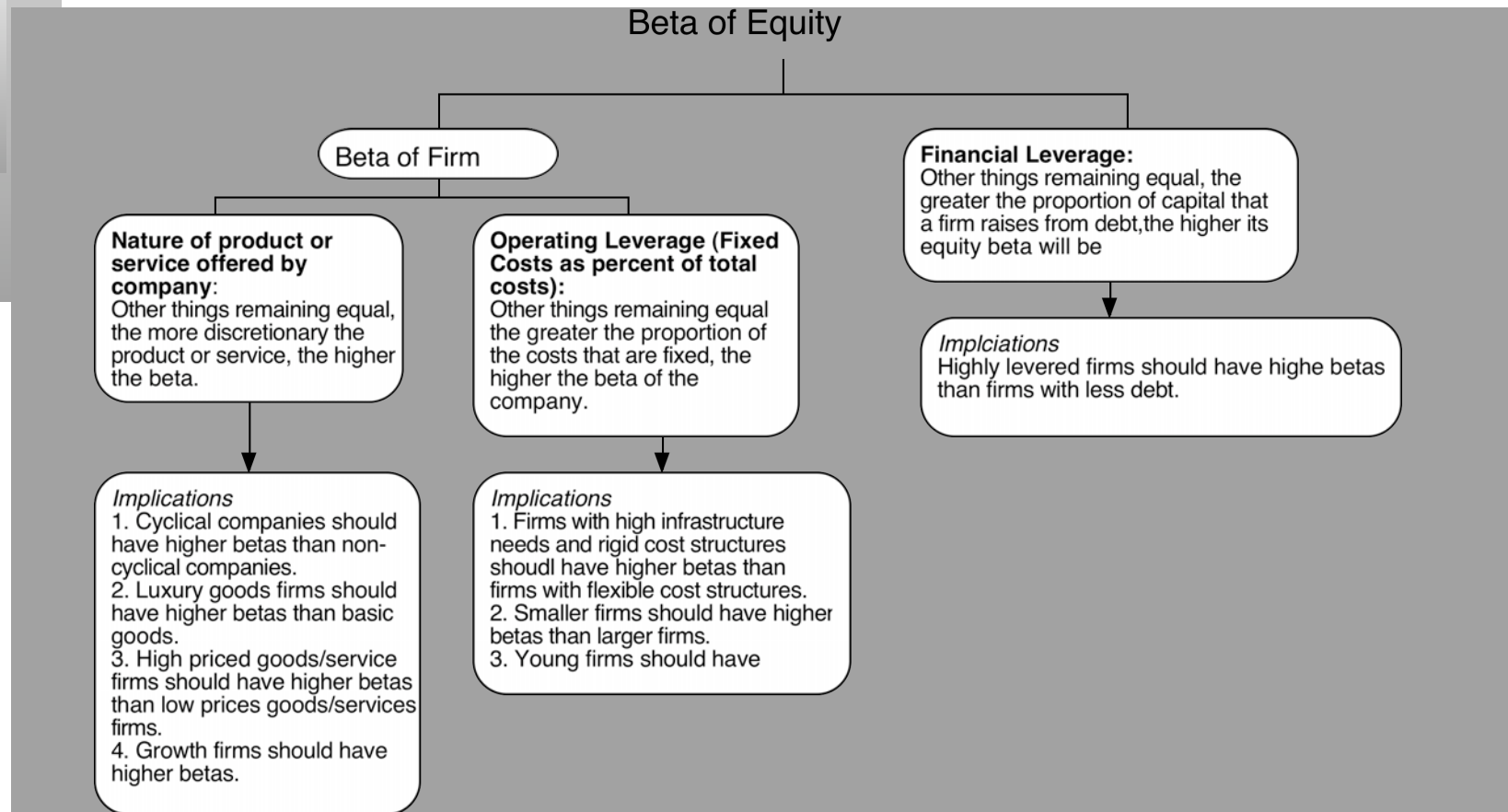

# Bottom-up Betas

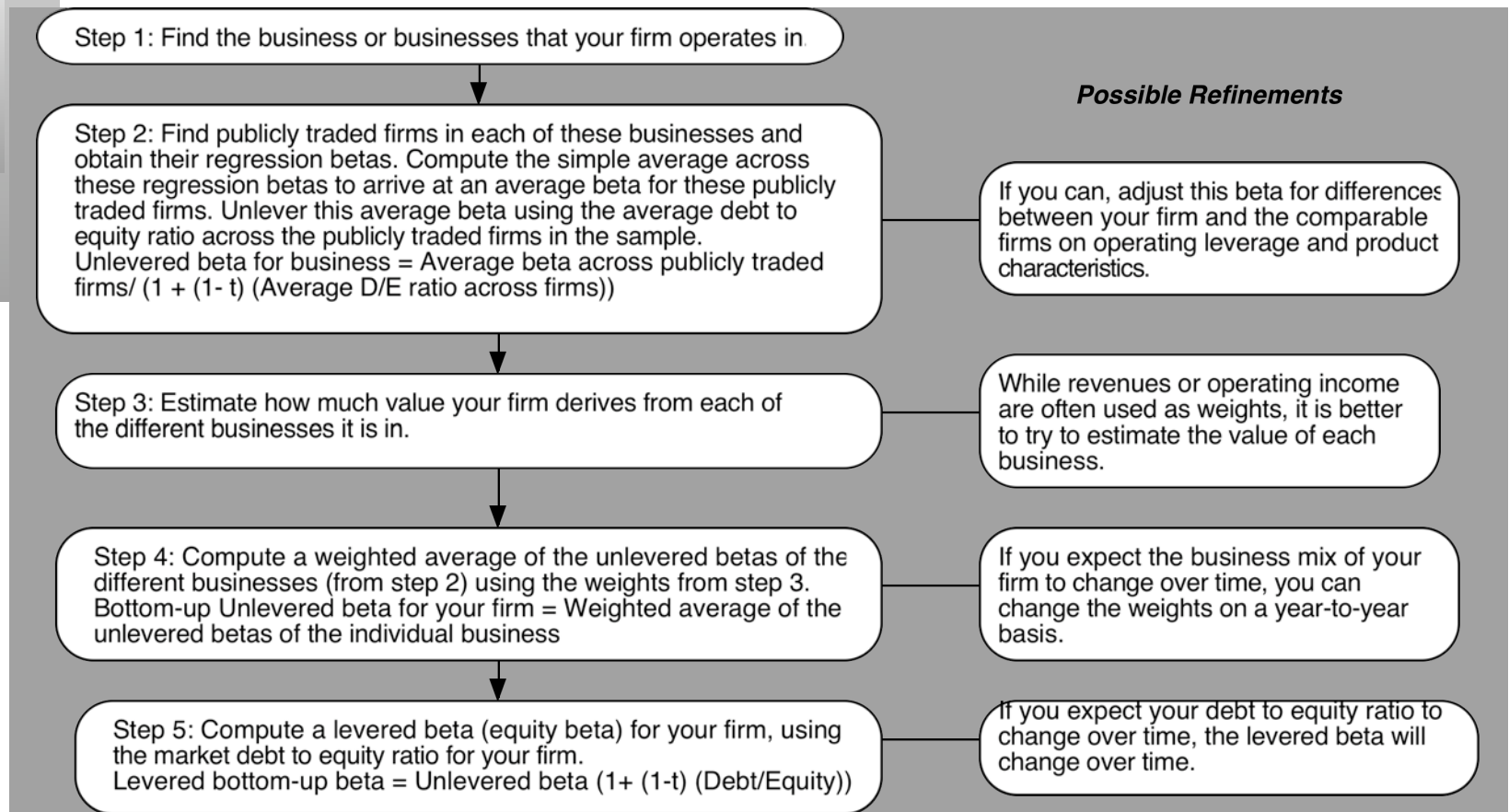

## Hyundai: Breaking down businesses

Business	Revenues	EV/Sales	Value	Value Weight	Unlevered beta
Shipbuilding	8341	3.23	26941	63.73%	1.60
Offshore & Engineering	2563	1.97	5049	11.94%	1.44
Industrial plant	1200	1.55	1860	4.40%	1.29
Engine and Machinery	2252	1.36	3063	7.24%	1.21
Electro Electric System	1753	1.8	3155	7.46%	1.19
Construction Equipment	1823	1.21	2206	5.22%	1.29
			42274	100.00%	1.49

## Bottom up Beta Estimates

<i>Company</i>	<i>Comparable Companies</i>	<i>Unlevered Beta</i>	<i>Levered Beta</i>
Hyundai Heavy	See last page	1.49	$1.49 (1 + (1-.275) (.0069)) = 1.50$
Amazon (First 5 years)	Internet Retailers	1.58	$1.58 (1 - (1-0) (.0121)) = 1.60$
Amazon (After year 5)	Specialty Retailers		1.00
Kristin Kandy	Food Processing companies with market cap < \$ 250 million	0.78	$0.78 ( 1+(1-.4) (30/70)) = 0.98$



## Small Firm and Other Premiums

---

- It is common practice to add premiums on to the cost of equity for firm-specific characteristics. For instance, many analysts add a small stock premium of 3-3.5% (historical premium for small stocks over the market) to the cost of equity for smaller companies.
- Adding arbitrary premiums to the cost of equity is always a dangerous exercise. If small stocks are riskier than larger stocks, we need to specify the reasons and try to quantify them rather than trust historical averages. (You could argue that smaller companies are more likely to serve niche (discretionary) markets or have higher operating leverage and adjust the beta to reflect this tendency).

## Is Beta an Adequate Measure of Risk for a Private Firm?

---

The owners of most private firms are not diversified. Beta measures the risk added on to a diversified portfolio. Therefore, using beta to arrive at a cost of equity for a private firm will

- a) Under estimate the cost of equity for the private firm
- b) Over estimate the cost of equity for the private firm
- c) Could under or over estimate the cost of equity for the private firm

## Total Risk versus Market Risk

---

- Adjust the beta to reflect total risk rather than market risk. This adjustment is a relatively simple one, since the R squared of the regression measures the proportion of the risk that is market risk.

Total Beta = Market Beta / Correlation of the sector with the market

- To estimate the beta for Kristin Kandy, we begin with the bottom-up unlevered beta of food processing companies:
  - Unlevered beta for publicly traded food processing companies = 0.78
  - Average correlation of food processing companies with market = 0.333
  - Unlevered total beta for Kristin Kandy =  $0.78/0.333 = 2.34$
  - Debt to equity ratio for Kristin Kandy =  $0.3/0.7$  (assumed industry average)
  - Total Beta =  $2.34 ( 1 - (1-.40)(30/70)) = 2.94$
  - Total Cost of Equity =  $4.50\% + 2.94 (4\%) = 16.26\%$

## When would you use this total risk measure?

---

- Under which of the following scenarios are you most likely to use the total risk measure:
  - when valuing a private firm for an initial public offering
  - when valuing a private firm for sale to a publicly traded firm
  - when valuing a private firm for sale to another private investor
- Assume that you own a private business. What does this tell you about the best potential buyer for your business?

# From Cost of Equity to Cost of Capital

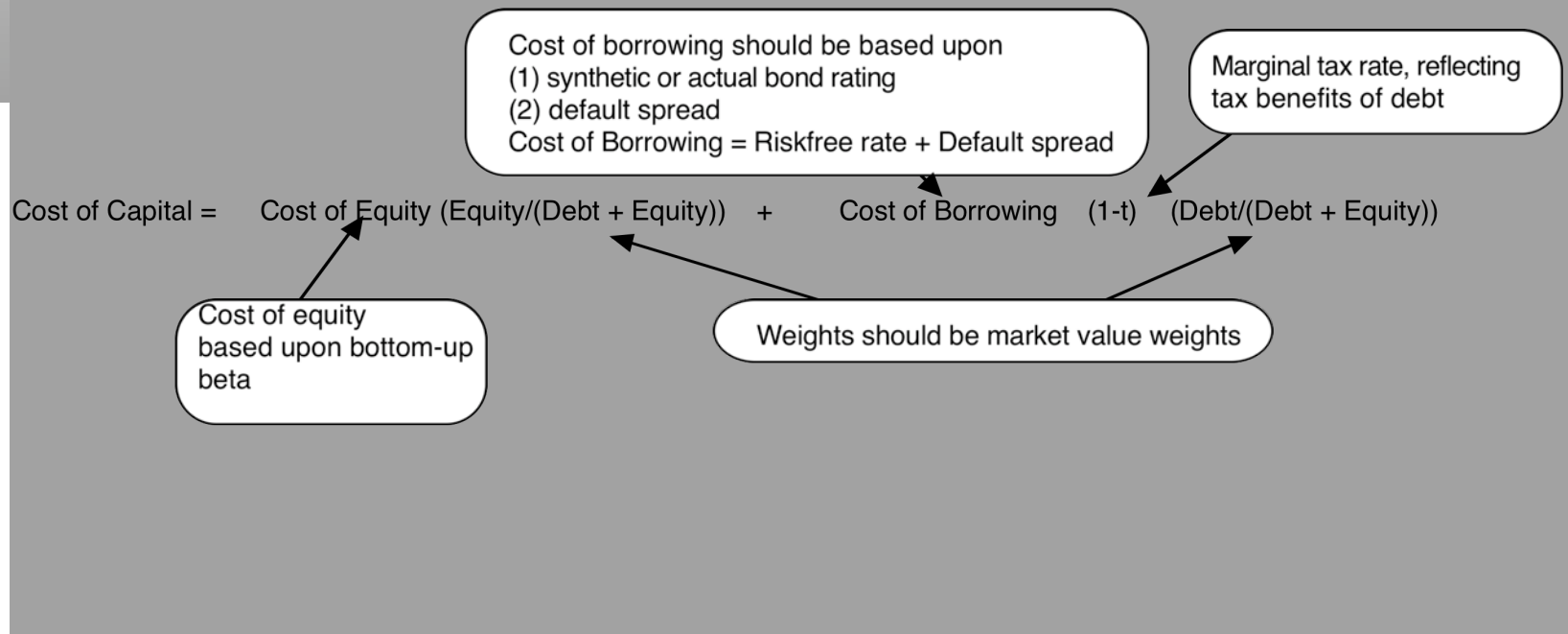

# What is debt?

---

- General Rule: Debt generally has the following characteristics:
  - Commitment to make fixed payments in the future
  - The fixed payments are tax deductible
  - Failure to make the payments can lead to either default or loss of control of the firm to the party to whom payments are due.
- As a consequence, debt should include
  - Any interest-bearing liability, whether short term or long term.
  - Any lease obligation, whether operating or capital.

## Hyundai's liabilities...

<u>LIABILITIES AND SHAREHOLDERS' EQUITY</u>	<u>Korean won</u>	
	<u>2007</u>	<u>2006</u>
	(In thousands)	
<b>CURRENT LIABILITIES:</b>		
Current maturities of debentures and long-term borrowings, net of discounts of ₩298,966 thousand in 2007 (Notes 9 and 22)	₩ 187,341,034	₩ 341,960
Trade accounts and notes payable (Notes 21 and 22)	1,495,173,461	1,179,763,488
Accounts payable-other (Notes 21 and 22)	122,492,217	125,989,605
Advances from customers ( Note 17)	8,013,303,994	6,262,761,712
Accrued expenses (Notes 21 and 22)	250,899,632	188,086,233
Income tax payable (Note 18)	455,564,205	167,718,040
Foreign exchange forward contracts (Note 11)	205,986,451	2,267,788
Deferred income tax liabilities (Notes 11 and 18)	-	38,716,339
Withholdings and other current liabilities (Notes 17 and 22)	<u>156,881,303</u>	<u>187,804,932</u>
<b>Total current liabilities</b>	<u>10,887,642,297</u>	<u>8,153,450,097</u>
<b>LONG-TERM LIABILITIES:</b>		
Debentures and long-term borrowings, net of discounts of ₩710,750 thousand in 2006 (Notes 9 and 22)	1,625,627	186,552,277
Accrued severance benefits, net of severance insurance deposits and others of ₩1,079,968,485 thousand in 2007 and ₩941,839,903 thousand in 2006 (Note 10)	110,865,582	193,348,583
Long-term accrued expenses	1,029,342	2,269,234
Deferred income tax liabilities (Notes 11 and 18)	257,968,531	81,371,661
Other long-term liabilities (Note 21)	<u>73,455,854</u>	<u>58,321,740</u>
<b>Total long-term liabilities</b>	<u>444,944,936</u>	<u>521,863,495</u>
<b>Total Liabilities</b>	<u>11,332,587,233</u>	<u>8,675,313,592</u>

## Estimating the Cost of Debt

---

- If the firm has bonds outstanding, and the bonds are traded, the yield to maturity on a long-term, straight (no special features) bond can be used as the interest rate.
- If the firm is rated, use the rating and a typical default spread on bonds with that rating to estimate the cost of debt.
- If the firm is not rated,
  - and it has recently borrowed long term from a bank, use the interest rate on the borrowing or
  - estimate a synthetic rating for the company, and use the synthetic rating to arrive at a default spread and a cost of debt
- The cost of debt has to be estimated in the same currency as the cost of equity and the cash flows in the valuation.



## Estimating Synthetic Ratings

---

- The rating for a firm can be estimated using the financial characteristics of the firm. In its simplest form, the rating can be estimated from the interest coverage ratio

$$\text{Interest Coverage Ratio} = \text{EBIT} / \text{Interest Expenses}$$

- For Hyundai's interest coverage ratio, we used the interest expenses and EBIT from 2007.

$$\text{Interest Coverage Ratio} = 1751 / 11 = 153.60$$

- For Kristin Kandy, we used the interest expenses and EBIT from the most recent financial year:

$$\text{Interest Coverage Ratio} = 500,000 / 85,000 = 5.88$$

- Amazon.com has negative operating income; this yields a negative interest coverage ratio, which should suggest a D rating. We computed an average interest coverage ratio of 2.82 over the next 5 years.

## Interest Coverage Ratios, Ratings and Default Spreads

If Interest Coverage Ratio is	Bond Rating	Default Spread(1/00)	Spread(1/04)	Spread (6/08)
> 8.50 (>12.50)	AAA	0.20%	0.35%	0.75%
6.50 - 8.50 (9.5-12.5)	AA	0.50%	0.50%	1.00%
5.50 - 6.50 (7.5-9.5)	A+	0.80%	0.70%	1.50%
4.25 - 5.50 (6-7.5)	A	1.00%	0.85%	1.80%
3.00 - 4.25 (4.5-6)	A-	1.25%	1.00%	2.00%
2.50 - 3.00 (3.5-4.5)	BBB	1.50%	1.50%	2.25%
2.25 - 2.50 (3.5 -4)	BB+	1.75%	2.00%	3.00%
2.00 - 2.25 ((3-3.5)	BB	2.00%	2.50%	3.50%
1.75 - 2.00 (2.5-3)	B+	2.50%	3.25%	4.75%
1.50 - 1.75 (2-2.5)	B	3.25%	4.00%	6.50%
1.25 - 1.50 (1.5-2)	B-	4.25%	6.00%	8.00%
0.80 - 1.25 (1.25-1.5)	CCC	5.00%	8.00%	10.00%
0.65 - 0.80 (0.8-1.25)	CC	6.00%	10.00%	11.50%
0.20 - 0.65 (0.5-0.8)	C	7.50%	12.00%	12.70%
< 0.20 (<0.5)	D	10.00%	20.00%	20.00%

For Hyundai and Kristin Kandy, I used the interest coverage ratio table for smaller/riskier firms (the numbers in brackets) which yields a lower rating for the same interest coverage ratio.

## Estimating the cost of debt for a firm

---

- The synthetic rating for Hyundai is AAA. Using the 2008 default spread of 0.75%, we estimate a cost of debt of 6.55% (using a riskfree rate of 5% and adding in the country default spread of 0.80%):

$$\begin{aligned}\text{Cost of debt} &= \text{Riskfree rate} + \text{Country default spread} + \text{Company default spread} \\ &= 5.00\% + 0.80\% + 0.75\% = 6.55\%\end{aligned}$$

- The synthetic rating for Kristin Kandy is A-. Using the 2004 default spread of 1.00% and a riskfree rate of 4.50%, we estimate a cost of debt of 5.50%.

$$\text{Cost of debt} = \text{Riskfree rate} + \text{Default spread} = 4.50\% + 1.00\% = 5.50\%$$

- The synthetic rating for Amazon.com in 2000 was BBB. The default spread for BBB rated bond was 1.50% in 2000 and the treasury bond rate was 6.5%.

$$\text{Cost of debt} = \text{Riskfree Rate} + \text{Default spread} = 6.50\% + 1.50\% = 8.00\%$$

## Weights for the Cost of Capital Computation

---

- The weights used to compute the cost of capital should be the market value weights for debt and equity.
- There is an element of circularity that is introduced into every valuation by doing this, since the values that we attach to the firm and equity at the end of the analysis are different from the values we gave them at the beginning.
- For private companies, neither the market value of equity nor the market value of debt is observable. Rather than use book value weights, you should try
  - Industry average debt ratios for publicly traded firms in the business
  - Target debt ratio (if management has such a target)
  - Estimated value of equity and debt from valuation (through an iterative process)

## Estimating Cost of Capital: Amazon.com

---

### ■ Equity

- Cost of Equity = 6.50% + 1.60 (4.00%) = 12.90%
- Market Value of Equity = \$ 84/share\* 340.79 mil shs = \$ 28,626 mil (98.8%)

### ■ Debt

- Cost of debt = 6.50% + 1.50% (default spread) = 8.00%
- Market Value of Debt = \$ 349 mil (1.2%)

### ■ Cost of Capital

$$\text{Cost of Capital} = 12.9 \% (.988) + 8.00\% (1 - 0) (.012) = 12.84\%$$

## Estimating Cost of Capital: Hyundai Heavy

### ■ Equity

- Cost of Equity =  $5\% + 1.50(4\%) + 0.25(1.20\%) = 11.30\%$
- Market Value of Equity = 27,740 billion Won (99.3%)

### ■ Debt

- Pre-tax Cost of debt =  $5\% + 0.80\% + 0.75\% = 6.55\%$
- Market Value of Debt = 185.58 billion Won (0.7%)

### ■ Cost of Capital

$$\text{Cost of Capital} = 11.30\% (.993) + 6.55\% (1 - .275)(0.007) = 11.26\%$$

The book value of equity at Hyundai Heavy is 5,492 billion Won

The book value of debt at Hyundai Heavy is 188 billion Won; Interest expense is 11.4 bil; Average maturity of debt = 3 years

Estimated market value of debt =  $11.4 \text{ billion (PV of annuity, 3 years, 6.55\%)} + \$188 \text{ billion} / 1.0655^3 = 185.58 \text{ billion Won}$

## Estimating Cost of Capital: Kristin Kandy

---

### ■ Equity

- Cost of Equity =  $4.50\% + 2.94 (4\%) = 16.26\%$
- Equity as percent of capital =  $70\%$

### ■ Debt

- Pre-tax Cost of debt =  $4.50\% + 1.00\% = 5.50\%$
- Marginal tax rate =  $40\%$
- Debt as percent of capital =  $30\%$  (Industry average)

### ■ Cost of Capital

$$\text{Cost of Capital} = 16.26\% (.70) + 5.50\% (1-.40) (.30) = 12.37\%$$



## II. Estimating Cashflows and Growth



# Defining Cashflow

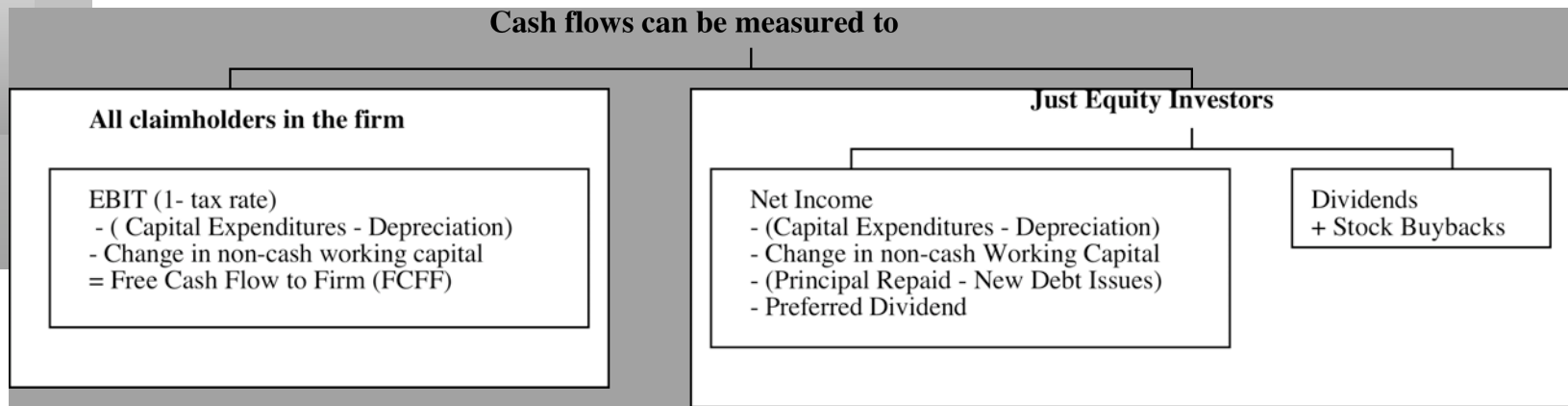

# From Reported to Actual Earnings

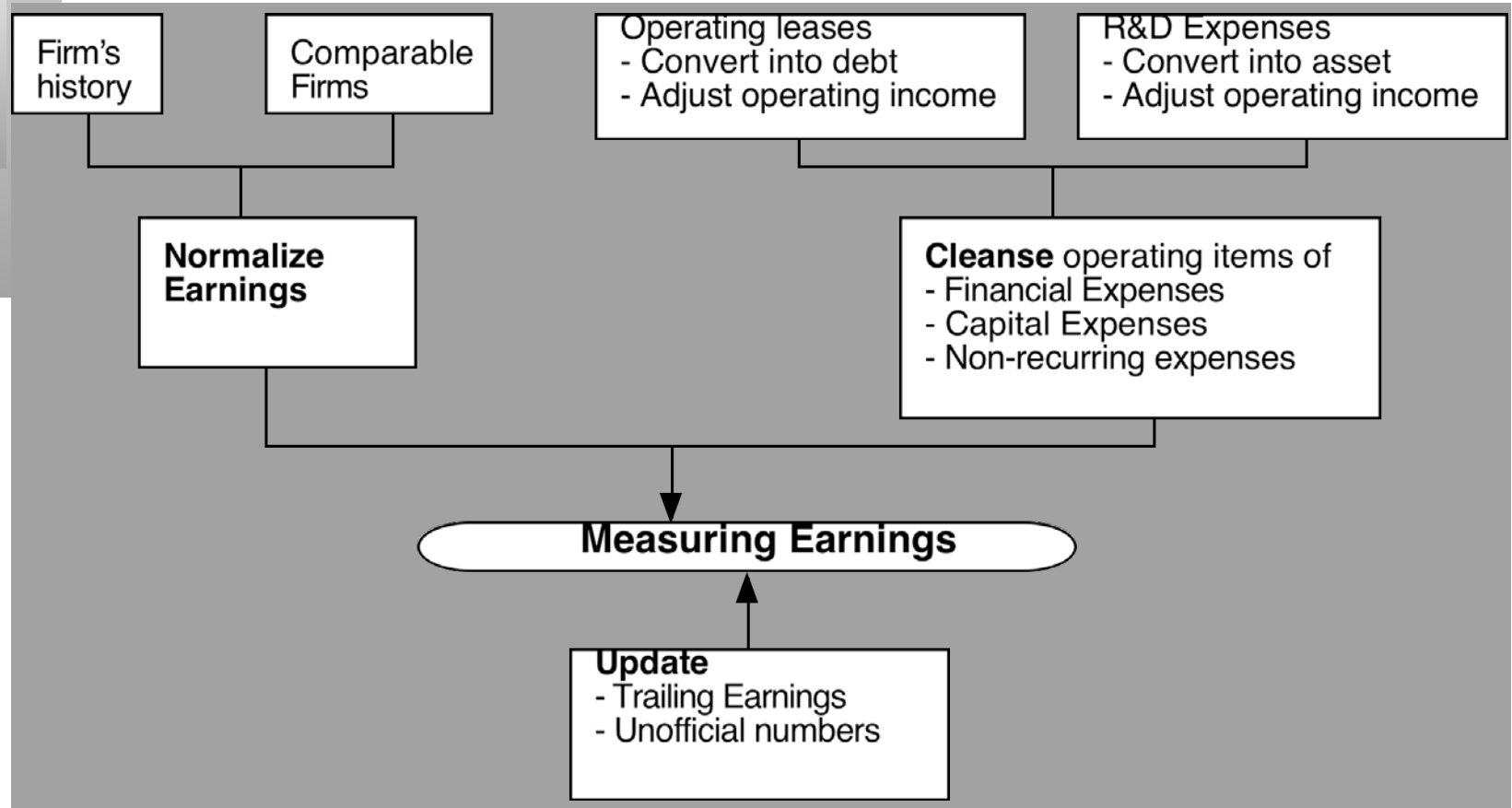

## Dealing with Operating Lease Expenses

---

- Operating Lease Expenses are treated as operating expenses in computing operating income. In reality, operating lease expenses should be treated as financing expenses, with the following adjustments to earnings and capital:
- Debt Value of Operating Leases = Present value of Operating Lease Commitments at the pre-tax cost of debt
- When you convert operating leases into debt, you also create an asset to counter it of exactly the same value.
- Adjusted Operating Earnings
  - Adjusted Operating Earnings = Operating Earnings + Operating Lease Expenses - Depreciation on Leased Asset
  - As an approximation, this works:  
Adjusted Operating Earnings = Operating Earnings + Pre-tax cost of Debt \* PV of Operating Leases.

## Operating Leases at The Gap in 2003

- The Gap has conventional debt of about \$ 1.97 billion on its balance sheet and its pre-tax cost of debt is about 6%. Its operating lease payments in the 2003 were \$978 million and its commitments for the future are below:

Year	Commitment (millions)	Present Value (at 6%)
1	\$899.00	\$848.11
2	\$846.00	\$752.94
3	\$738.00	\$619.64
4	\$598.00	\$473.67
5	\$477.00	\$356.44
6&7	\$982.50 each year	\$1,346.04
Debt Value of leases =		\$4,396.85 (Also value of leased asset)

- Debt outstanding at The Gap = \$1,970 m + \$4,397 m = \$6,367 m
- Adjusted Operating Income = Stated OI + OL exp this year - Deprec'n  
= \$1,012 m + 978 m - 4397 m /7 = \$1,362 million (7 year life for assets)
- Approximate OI = \$1,012 m + \$ 4397 m (.06) = \$1,276 m

## The Collateral Effects of Treating Operating Leases as Debt

<i>Conventional Accounting</i>	<i>Operating Leases Treated as Debt</i>								
<p><i>Income Statement</i></p> <p>EBIT &amp; Leases = 1,990                      - Op Leases = 978                      EBIT = 1,012</p>	<p><i>Income Statement</i></p> <p>EBIT &amp; Leases = 1,990                      - Deprecn: OL = 628                      EBIT = 1,362</p> <p>Interest expense will rise to reflect the conversion of operating leases as debt. Net income should not change.</p>								
<p><i>Balance Sheet</i></p> <p>Off balance sheet (Not shown as debt or as an asset). Only the conventional debt of \$1,970 million shows up on balance sheet</p>	<p><i>Balance Sheet</i></p> <table> <tr> <td>Asset</td> <td></td> <td>Liability</td> <td></td> </tr> <tr> <td>OL Asset</td> <td>4397</td> <td>OL Debt</td> <td>4397</td> </tr> </table> <p>Total debt = 4397 + 1970 = \$6,367 million</p>	Asset		Liability		OL Asset	4397	OL Debt	4397
Asset		Liability							
OL Asset	4397	OL Debt	4397						
<p>Cost of capital = 8.20%(7350/9320) + 4%(1970/9320) = 7.31%</p> <p>Cost of equity for The Gap = 8.20%</p> <p>After-tax cost of debt = 4%</p> <p>Market value of equity = 7350</p>	<p>Cost of capital = 8.20%(7350/13717) + 4%(6367/13717) = 6.25%</p>								
<p>Return on capital = 1012 (1-.35)/(3130+1970) = 12.90%</p>	<p>Return on capital = 1362 (1-.35)/(3130+6367) = 9.30%</p>								

## R&D Expenses: Operating or Capital Expenses

---

- Accounting standards require us to consider R&D as an operating expense even though it is designed to generate future growth. It is more logical to treat it as capital expenditures.
- To capitalize R&D,
  - Specify an amortizable life for R&D (2 - 10 years)
  - Collect past R&D expenses for as long as the amortizable life
  - Sum up the unamortized R&D over the period. (Thus, if the amortizable life is 5 years, the research asset can be obtained by adding up 1/5th of the R&D expense from five years ago, 2/5th of the R&D expense from four years ago...:

## Capitalizing R&D Expenses: Cisco in 1999

- R & D was assumed to have a 5-year life.

<i>Year</i>	<i>R&amp;D Expense</i>	<i>Unamortized portion</i>		<i>Amortization this year</i>
1999 (current)	1594.00	1.00	1594.00	
1998	1026.00	0.80	820.80	\$205.20
1997	698.00	0.60	418.80	\$139.60
1996	399.00	0.40	159.60	\$79.80
1995	211.00	0.20	42.20	\$42.20
1994	89.00	0.00	0.00	\$17.80
Total			\$ 3,035.40	\$ 484.60

Value of research asset = \$ 3,035.4 million

Amortization of research asset in 1998 = \$ 484.6 million

Adjustment to Operating Income = \$ 1,594 million - 484.6 million = 1,109.4 million

## The Effect of Capitalizing R&D

<i>Conventional Accounting</i>	<i>R&amp;D treated as capital expenditure</i>						
<p><i>Income Statement</i></p> <p>EBIT&amp; R&amp;D = 5,049                      - R&amp;D = 1,594                      EBIT = 3,455                      EBIT (1-t) = 2,246</p>	<p><i>Income Statement</i></p> <p>EBIT&amp; R&amp;D = 5,049                      - Amort: R&amp;D = 485                      EBIT = 4,564 (Increase of 1,109)                      EBIT (1-t) = 2,967                      Ignored tax benefit = (1594-485)(.35) = 388                      Adjusted EBIT (1-t) = 2967 + 388 = 3354                      (Increase of \$1,109 million)                      Net Income will also increase by \$1,109 million</p>						
<p><i>Balance Sheet</i></p> <p>Off balance sheet asset. Book value of equity at \$11,722 million is understated because biggest asset is off the books.</p>	<p><i>Balance Sheet</i></p> <table style="width: 100%; border: none;"> <tr> <td style="width: 50%; text-align: center;">Asset</td> <td style="width: 50%; text-align: center;">Liability</td> </tr> <tr> <td style="text-align: center;">R&amp;D Asset 3035</td> <td style="text-align: center;">Book Equity +3035</td> </tr> <tr> <td colspan="2" style="text-align: center;">Total Book Equity = 11722+3035 = 14757</td> </tr> </table>	Asset	Liability	R&D Asset 3035	Book Equity +3035	Total Book Equity = 11722+3035 = 14757	
Asset	Liability						
R&D Asset 3035	Book Equity +3035						
Total Book Equity = 11722+3035 = 14757							
<p><i>Capital Expenditures</i></p> <p>Conventional net cap ex of \$98 million</p>	<p><i>Capital Expenditures</i></p> <p>Net Cap ex = 98 + 1594 - 485 = 1206</p>						
<p><i>Cash Flows</i></p> <p>EBIT (1-t) = 2246                      - Net Cap Ex = 98                      FCFF = 2148</p>	<p><i>Cash Flows</i></p> <p>EBIT (1-t) = 3354                      - Net Cap Ex = 1206                      FCFF = 2148</p>						
<p>Return on capital = 2246/11722 (no debt)                      = 19.16%</p>	<p>Return on capital = 3354/14757                      = 22.78%</p>						



## What tax rate?

---

- The tax rate that you should use in computing the after-tax operating income should be
  - ❑ The effective tax rate in the financial statements (taxes paid/Taxable income)
  - ❑ The tax rate based upon taxes paid and EBIT (taxes paid/EBIT)
  - ❑ The marginal tax rate for the country in which the company operates
  - ❑ The weighted average marginal tax rate across the countries in which the company operates
  - ❑ None of the above
  - ❑ Any of the above, as long as you compute your after-tax cost of debt using the same tax rate

## Capital expenditures should include

---

- Research and development expenses, once they have been re-categorized as capital expenses. The adjusted net cap ex will be  
$$\text{Adjusted Net Capital Expenditures} = \text{Net Capital Expenditures} + \text{Current year's R\&D expenses} - \text{Amortization of Research Asset}$$
  - Acquisitions of other firms, since these are like capital expenditures. The adjusted net cap ex will be  
$$\text{Adjusted Net Cap Ex} = \text{Net Capital Expenditures} + \text{Acquisitions of other firms} - \text{Amortization of such acquisitions}$$
- Two caveats:
1. Most firms do not do acquisitions every year. Hence, a normalized measure of acquisitions (looking at an average over time) should be used
  2. The best place to find acquisitions is in the statement of cash flows, usually categorized under other investment activities

## Cisco's Net Capital Expenditures in 1999

---

Cap Expenditures (from statement of CF)	= \$ 584 mil
- Depreciation (from statement of CF)	= \$ 486 mil
Net Cap Ex (from statement of CF)	= \$ 98 mil
+ R & D expense	= \$ 1,594 mil
- Amortization of R&D	= \$ 485 mil
+ Acquisitions	= \$ 2,516 mil
Adjusted Net Capital Expenditures	= \$3,723 mil

(Amortization was included in the depreciation number)

## Working Capital Investments

---

- In accounting terms, the working capital is the difference between current assets (inventory, cash and accounts receivable) and current liabilities (accounts payables, short term debt and debt due within the next year)
- A cleaner definition of working capital from a cash flow perspective is the difference between non-cash current assets (inventory and accounts receivable) and non-debt current liabilities (accounts payable)
- Any investment in this measure of working capital ties up cash. Therefore, any increases (decreases) in working capital will reduce (increase) cash flows in that period.
- When forecasting future growth, it is important to forecast the effects of such growth on working capital needs, and building these effects into the cash flows.

# Dealing with Negative or Abnormally Low Earnings

## A Framework for Analyzing Companies with Negative or Abnormally Low Earnings

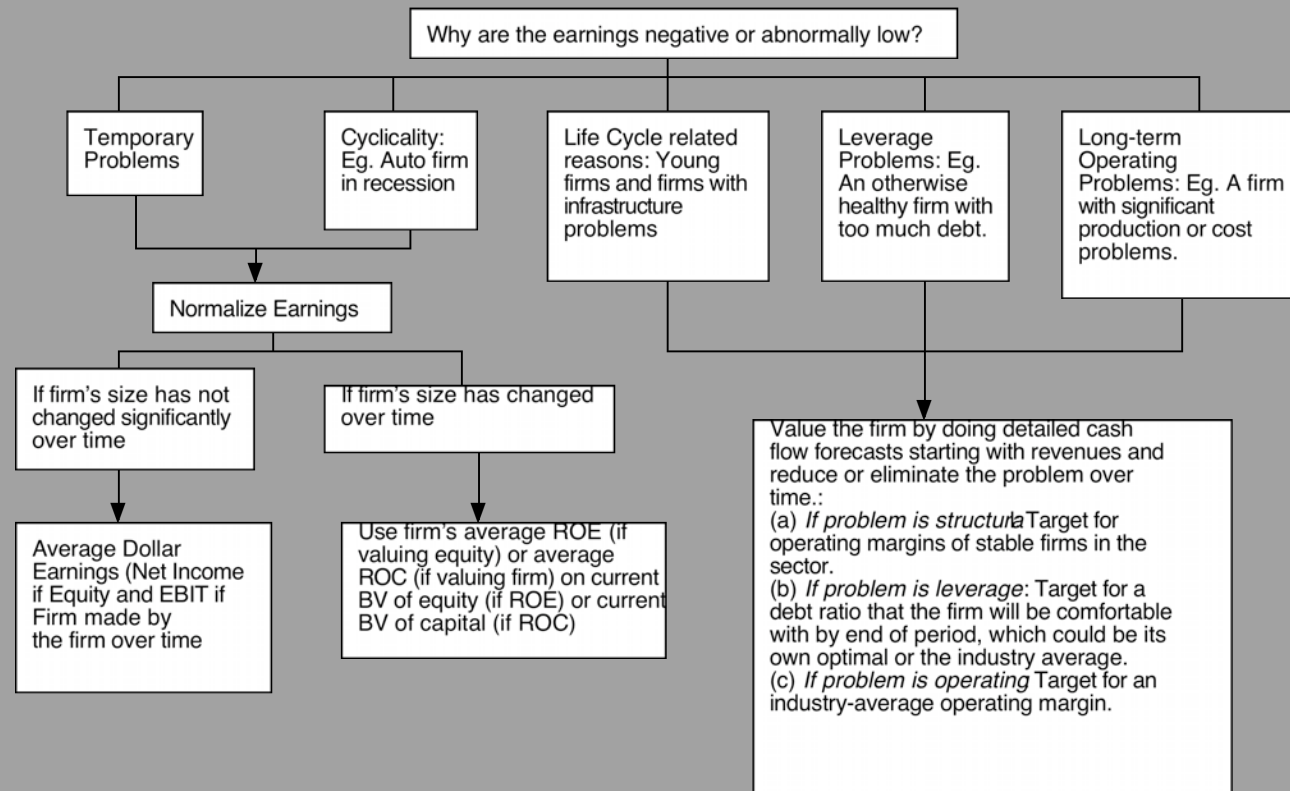

## Normalizing Earnings: Amazon

Year	Revenues	Operating Margin	EBIT	
Tr12m	\$1,117	-36.71%	-\$410	
1	\$2,793	-13.35%	-\$373	
2	\$5,585	-1.68%	-\$94	
3	\$9,774	4.16%	\$407	
4	\$14,661	7.08%	\$1,038	
5	\$19,059	8.54%	\$1,628	
6	\$23,862	9.27%	\$2,212	
7	\$28,729	9.64%	\$2,768	
8	\$33,211	9.82%	\$3,261	
9	\$36,798	9.91%	\$3,646	
10	\$39,006	9.95%	\$3,883	
<b>TY(11)</b>	<b>\$41,346</b>	<b>10.00%</b>	<b>\$4,135</b>	<b>Industry Average</b>

## Estimating FCFF: Hyundai Heavy Industries

---

- EBIT = 1,751 billion Won
- Tax rate = 27.5%
- Net Capital expenditures = Cap Ex - Depreciation = 911 - 392 = 519 billion W
- Change in Working Capital = - 135 billion Won

### **Estimating FCFF**

Current EBIT * (1 - tax rate) =	1751 (1-.275) =	1,269 billion Won
- (Capital Spending - Depreciation)		519 billion Won
- Change in Working Capital		135 billion Won
Current FCFF		615 billion Won

Reinvestment in 2007 = 519 + 135 = 654 billion Won

Reinvestment rate = 654/1269 = 51.52%

## Estimating FCFF: Amazon.com

---

- EBIT (Trailing 1999) = -\$ 410 million
- Tax rate used = 0% (Assumed Effective = Marginal)
- Capital spending (Trailing 1999) = \$ 243 million
- Depreciation (Trailing 1999) = \$ 31 million
- Non-cash Working capital Change (1999) = - 80 million
- Estimating FCFF (1999)
  - Current EBIT \* (1 - tax rate) = - 410 (1-0) = - \$410 million
  - (Capital Spending - Depreciation) = \$212 million
  - Change in Working Capital = -\$ 80 million
  - Current FCFF = - \$542 million



## Growth in Earnings

---

- Look at the past
  - The historical growth in earnings per share is usually a good starting point for growth estimation
- Look at what others are estimating
  - Analysts estimate growth in earnings per share for many firms. It is useful to know what their estimates are.
- Look at fundamentals
  - Ultimately, all growth in earnings can be traced to two fundamentals - how much the firm is investing in new projects, and what returns these projects are making for the firm.

## Fundamental Growth when Returns are stable

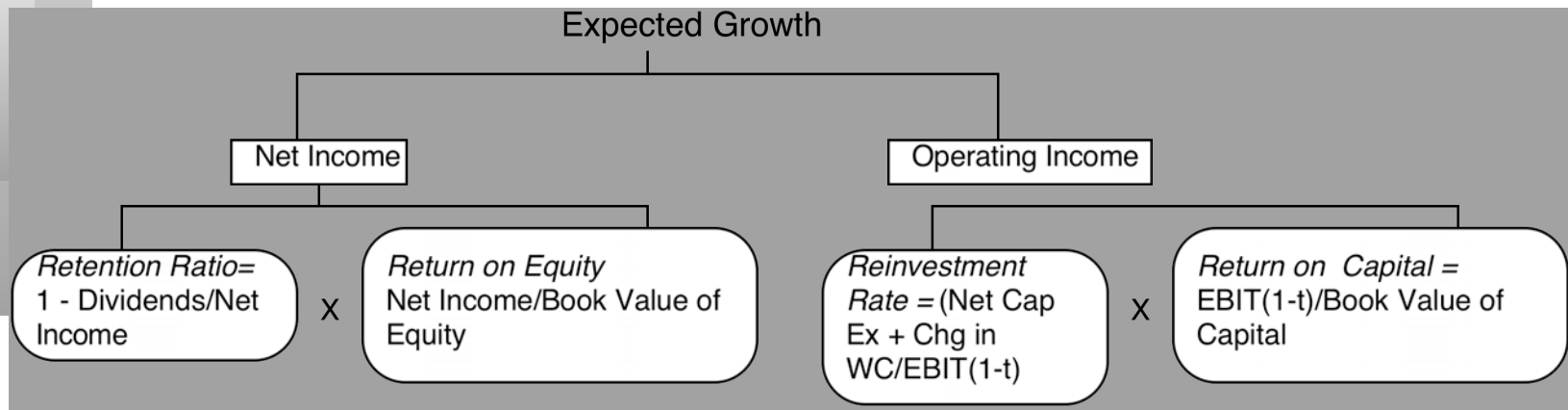

## Measuring Return on Capital (Equity)

Adjust EBIT for

- a. Extraordinary or one-time expenses or income
- b. Operating leases and R&D
- c. Cyclical in earnings (Normalize)
- d. Acquisition Debris (Goodwill amortization etc.)

Use a marginal tax rate to be safe. A high ROC created by paying low effective taxes is not sustainable

$$\text{ROC} = \frac{\text{EBIT ( 1- tax rate)}}{\text{Book Value of Equity + Book value of debt - Cash}}$$

Adjust book equity for

1. Capitalized R&D
2. Acquisition Debris (Goodwill)

Adjust book value of debt for

- a. Capitalized operating leases

Use end of prior year numbers or average over the year but be consistent in your application

## Expected Growth Estimate: Hyundai Heavy

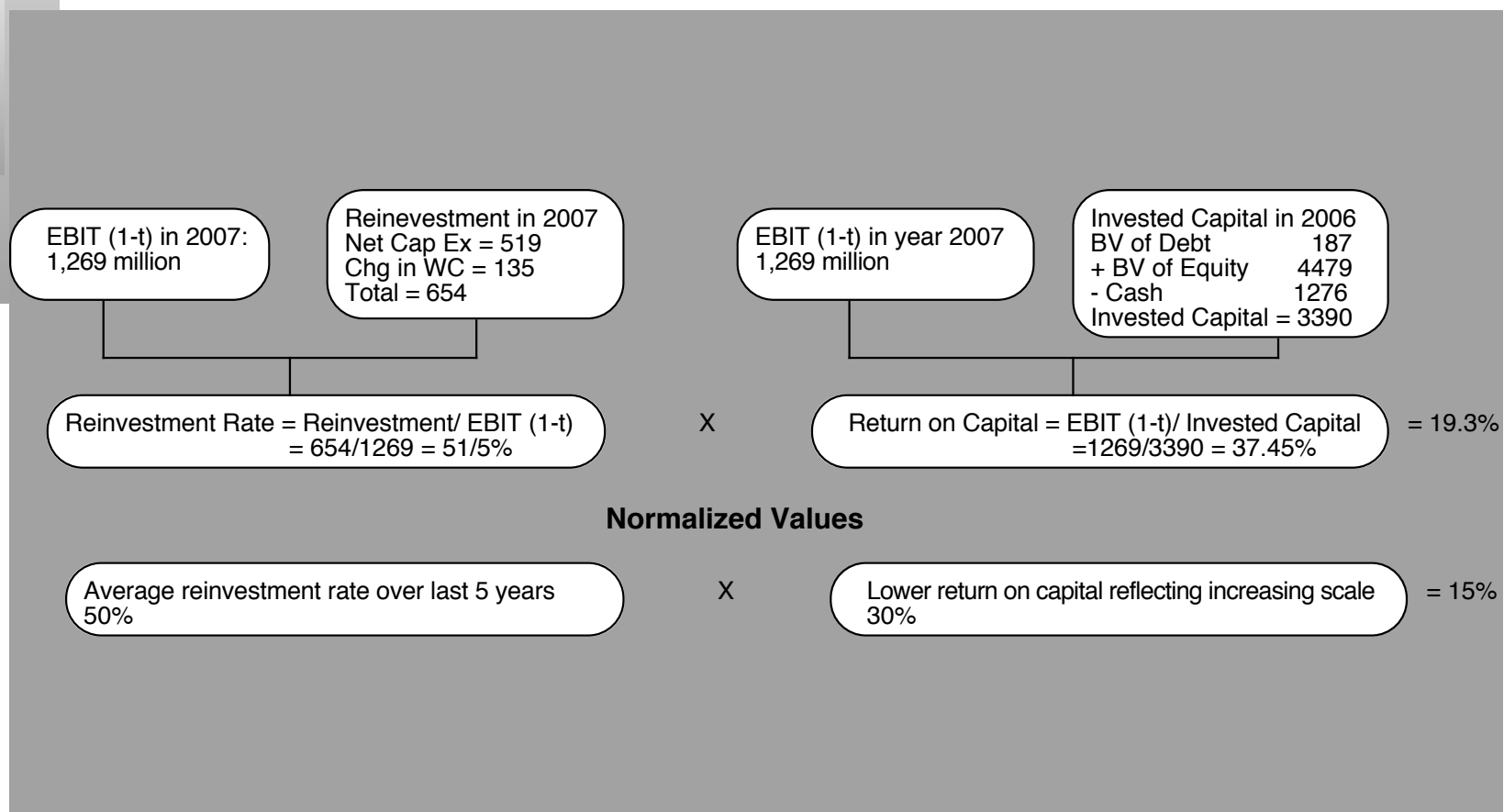

## Expected Growth Estimate: Wells Fargo

Net Income in trailing 12 months: \$7,147 million

Dividends in trailing 12 months: \$3,955 million

Retention Ratio =  $1 - \text{Dividends} / \text{Net Income}$   
 $= 1 - 3904 / 7147 = 45.37\%$

Net Income in trailing 12 months: \$7,147 million

Book Value of Equity at start of period: \$45,876 million

Return on Capital =  $\text{EBIT} (1-t) / \text{Invested Capital}$   
 $= 7147 / 45876 = 17.56\%$

X

### Normalized Values

Retention ratio will be maintained at current year's level of 45.37%

X

Assuming that regulatory changes will increase need for book capital by 30% lowers the return on equity to 13.5%  
 $7147 / (45876 * 1.30) = 0.135$

## Fundamental Growth when return on equity (capital) is changing

---

- When the return on equity or capital is changing, there will be a second component to growth, positive if the return is increasing and negative if the return is decreasing. If  $ROC_t$  is the return on capital in period  $t$  and  $ROC_{t+1}$  is the return on capital in period  $t+1$ , the expected growth rate in operating income will be:

$$\text{Expected Growth Rate} = ROC_{t+1} * \text{Reinvestment rate} \\ + (ROC_{t+1} - ROC_t) / ROC_t$$

- For example, assume that you have a firm that is generating a return on capital of 8% on its existing assets and expects to increase this return to 10% next year. The efficiency growth for this firm is

$$\text{Efficiency growth} = (10\% - 8\%) / 8\% = 25\%$$

Thus, if this firm has a reinvestment rate of 50% and makes a 10% return on capital on its new investments as well, its total growth next year will be 30%

$$\text{Growth rate} = .50 * 10\% + 25\% = 30\%$$

The key difference is that growth from new investments is sustainable whereas returns from efficiency are short term (or transitory).

## Revenue Growth and Operating Margins

---

- With negative operating income and a negative return on capital, the fundamental growth equation is of little use for Amazon.com
- For Amazon, the effect of reinvestment shows up in revenue growth rates and changes in expected operating margins:

Expected Revenue Growth in \$ = Reinvestment (in \$ terms) \* (Sales/ Capital)

- The effect on expected margins is more subtle. Amazon's reinvestments (especially in acquisitions) may help create barriers to entry and other competitive advantages that will ultimately translate into high operating margins and high profits.

## Growth in Revenues, Earnings and Reinvestment: Amazon

Year	Revenue Growth	Chg in Revenue	Reinvestment	Chg Rev/ Chg Reinvestment	ROC
1	150.00%	\$1,676	\$559	3.00	-76.62%
2	100.00%	\$2,793	\$931	3.00	-8.96%
3	75.00%	\$4,189	\$1,396	3.00	20.59%
4	50.00%	\$4,887	\$1,629	3.00	25.82%
5	30.00%	\$4,398	\$1,466	3.00	21.16%
6	25.20%	\$4,803	\$1,601	3.00	22.23%
7	20.40%	\$4,868	\$1,623	3.00	22.30%
8	15.60%	\$4,482	\$1,494	3.00	21.87%
9	10.80%	\$3,587	\$1,196	3.00	21.19%
10	6.00%	\$2,208	\$736	3.00	20.39%

Assume that firm can earn high returns because of established economies of scale.



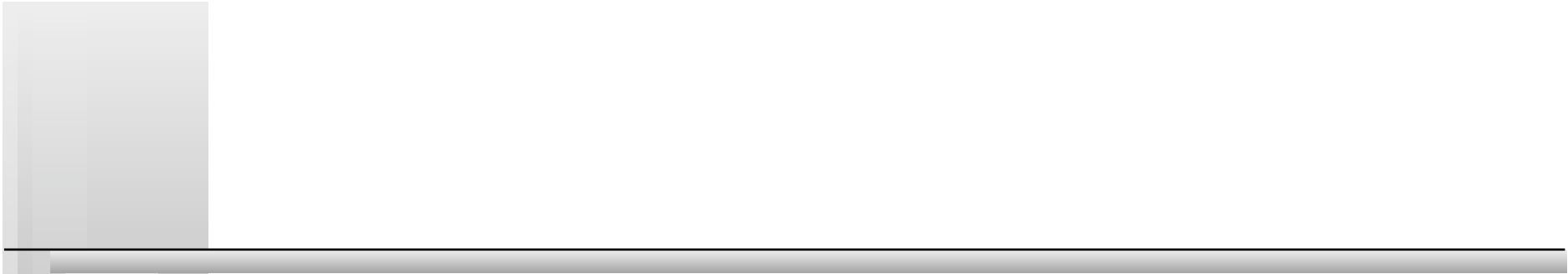

### III. The Tail that wags the dog... Terminal Value

## Getting Closure in Valuation

- A publicly traded firm potentially has an infinite life. The value is therefore the present value of cash flows forever.

$$\text{Value} = \sum_{t=1}^{t=\infty} \frac{CF_t}{(1+r)^t}$$

- Since we cannot estimate cash flows forever, we estimate cash flows for a “growth period” and then estimate a terminal value, to capture the value at the end of the period:

$$\text{Value} = \sum_{t=1}^{t=N} \frac{CF_t}{(1+r)^t} + \frac{\text{Terminal Value}}{(1+r)^N}$$

## Ways of Estimating Terminal Value

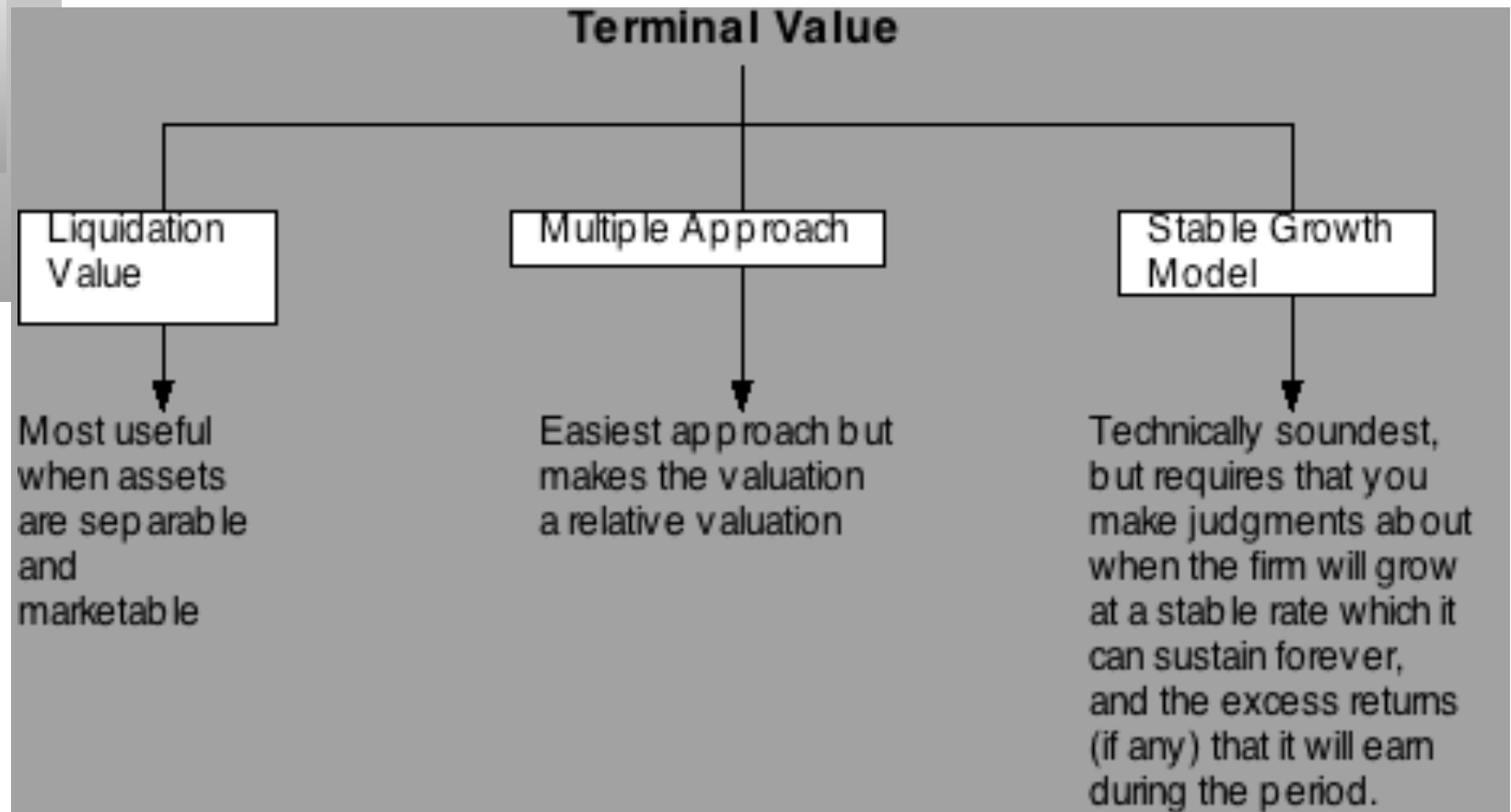

## Stable Growth and Terminal Value

---

- When a firm's cash flows grow at a “constant” rate forever, the present value of those cash flows can be written as:  
Value = Expected Cash Flow Next Period / (r - g)  
where,  
r = Discount rate (Cost of Equity or Cost of Capital)  
g = Expected growth rate
- This “constant” growth rate is called a stable growth rate and cannot be higher than the growth rate of the economy in which the firm operates.
- While companies can maintain high growth rates for extended periods, they will all approach “stable growth” at some point in time.

# 1. How high can the stable growth rate be?

---

- The stable growth rate cannot exceed the growth rate of the economy but it can be set lower.
  - If you assume that the economy is composed of high growth and stable growth firms, the growth rate of the latter will probably be lower than the growth rate of the economy.
  - The stable growth rate can be negative. The terminal value will be lower and you are assuming that your firm will disappear over time.
  - If you use nominal cashflows and discount rates, the growth rate should be nominal in the currency in which the valuation is denominated.
- One simple proxy for the nominal growth rate of the economy is the riskfree rate.
  - Riskfree rate = Expected inflation + Expected Real Interest Rate
  - Nominal growth rate in economy = Expected Inflation + Expected Real Growth

## 2. When will the firm reach stable growth?

---

- Size of the firm
  - Success usually makes a firm larger. As firms become larger, it becomes much more difficult for them to maintain high growth rates
- Current growth rate
  - While past growth is not always a reliable indicator of future growth, there is a correlation between current growth and future growth. Thus, a firm growing at 30% currently probably has higher growth and a longer expected growth period than one growing 10% a year now.
- Barriers to entry and differential advantages
  - Ultimately, high growth comes from high project returns, which, in turn, comes from barriers to entry and differential advantages.
  - The question of how long growth will last and how high it will be can therefore be framed as a question about what the barriers to entry are, how long they will stay up and how strong they will remain.

### 3. What else should change in stable growth?

---

- In stable growth, firms should have the characteristics of other stable growth firms. In particular,
  - The risk of the firm, as measured by beta and ratings, should reflect that of a stable growth firm.
    - Beta should move towards one
    - The cost of debt should reflect the safety of stable firms (BBB or higher)
  - The debt ratio of the firm might increase to reflect the larger and more stable earnings of these firms.
    - The debt ratio of the firm might moved to the optimal or an industry average
    - If the managers of the firm are deeply averse to debt, this may never happen
  - The return on capital generated on investments should move to sustainable levels, relative to both the sector and the company's own cost of capital.

## 4. What excess returns will you generate in stable growth and why does it matter?

---

- Strange though this may seem, the terminal value is not as much a function of stable growth as it is a function of what you assume about excess returns in stable growth.
- The key connecting link is the reinvestment rate that you have in stable growth, which is a function of your return on capital:

$$\text{Reinvestment Rate} = \text{Stable growth rate} / \text{Stable ROC}$$

The terminal value can be written in terms of ROC as follows:

$$\text{Terminal Value} = \text{EBIT}_{n+1} (1-t) (1 - g/ \text{ROC}) / (\text{Cost of capital} - g)$$

- In the scenario where you assume that a firm earns a return on capital equal to its cost of capital in stable growth, the terminal value will not change as the growth rate changes.
- If you assume that your firm will earn positive (negative) excess returns in perpetuity, the terminal value will increase (decrease) as the stable growth rate increases.



## Hyundai and Amazon.com: Stable Growth Inputs

	<i>High Growth</i>	<i>Stable Growth</i>
■ Hyundai Heavy		
• Beta	1.50	1.20
• Debt Ratio	0.7%	10%
• Return on Capital	30%	9.42%
• Cost of Capital	11.26%	9.42%
• Expected Growth Rate	15%	5%
• Reinvestment Rate	50%	$5\%/9.42\% = 53.1\%$
■ Amazon.com		
• Beta	1.60	1.00
• Debt Ratio	1.20%	15%
• Return on Capital	Negative	20%
• Expected Growth Rate	NMF	6%
• Reinvestment Rate	>100%	$6\%/20\% = 30\%$

## Hyundai: Terminal Value and Growth

Growth Rate	Reinvestment Rate	FCFF	Terminal value
0%	0.00%	₩2,681	₩28,471
1%	10.62%	₩2,396	₩28,471
2%	21.24%	₩2,112	₩28,471
3%	31.86%	₩1,827	₩28,471
4%	42.48%	₩1,542	₩28,471
5%	53.10%	₩1,258	₩28,471

As growth increases, value does not change. Why?

Under what conditions will value increase as growth increases?

Under what conditions will value decrease as growth increases?



# Value Enhancement: Back to Basics

# Price Enhancement versus Value E

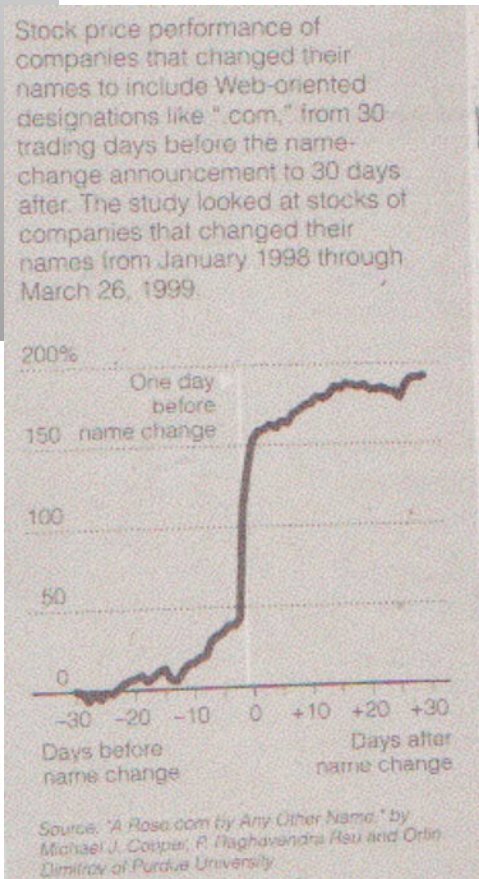

## NAME THAT STOCK

### New Markets, New Names

In the bull market, adding dot-com to a company name made a stock soar. Lately those zippy new monikers are disappearing.

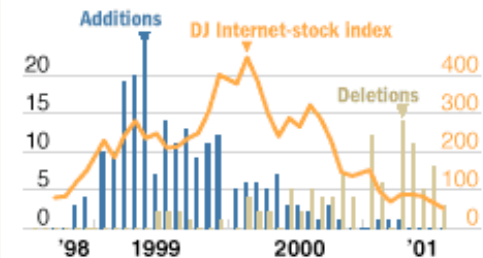

### New Name, Higher Price

But the stocks still get a bounce when dot-com goes away. Chart shows returns in the days before and after the name change.



Sources: Thomson Datastream; P. Raghavendra Rau, Michael J. Cooper, Igor Osobov, Purdue Univ.; Ajay Khorana, Virginia Univ.; Ajay Patel, Wake Forest Univ.

## The Paths to Value Creation

---

- Using the DCF framework, there are four basic ways in which the value of a firm can be enhanced:
  - The cash flows from existing assets to the firm can be increased, by either
    - increasing after-tax earnings from assets in place or
    - reducing reinvestment needs (net capital expenditures or working capital)
  - The expected growth rate in these cash flows can be increased by either
    - Increasing the rate of reinvestment in the firm
    - Improving the return on capital on those reinvestments
  - The length of the high growth period can be extended to allow for more years of high growth.
  - The cost of capital can be reduced by
    - Reducing the operating risk in investments/assets
    - Changing the financial mix
    - Changing the financing composition

## Value Creation 1: Increase Cash Flows from Assets in Place

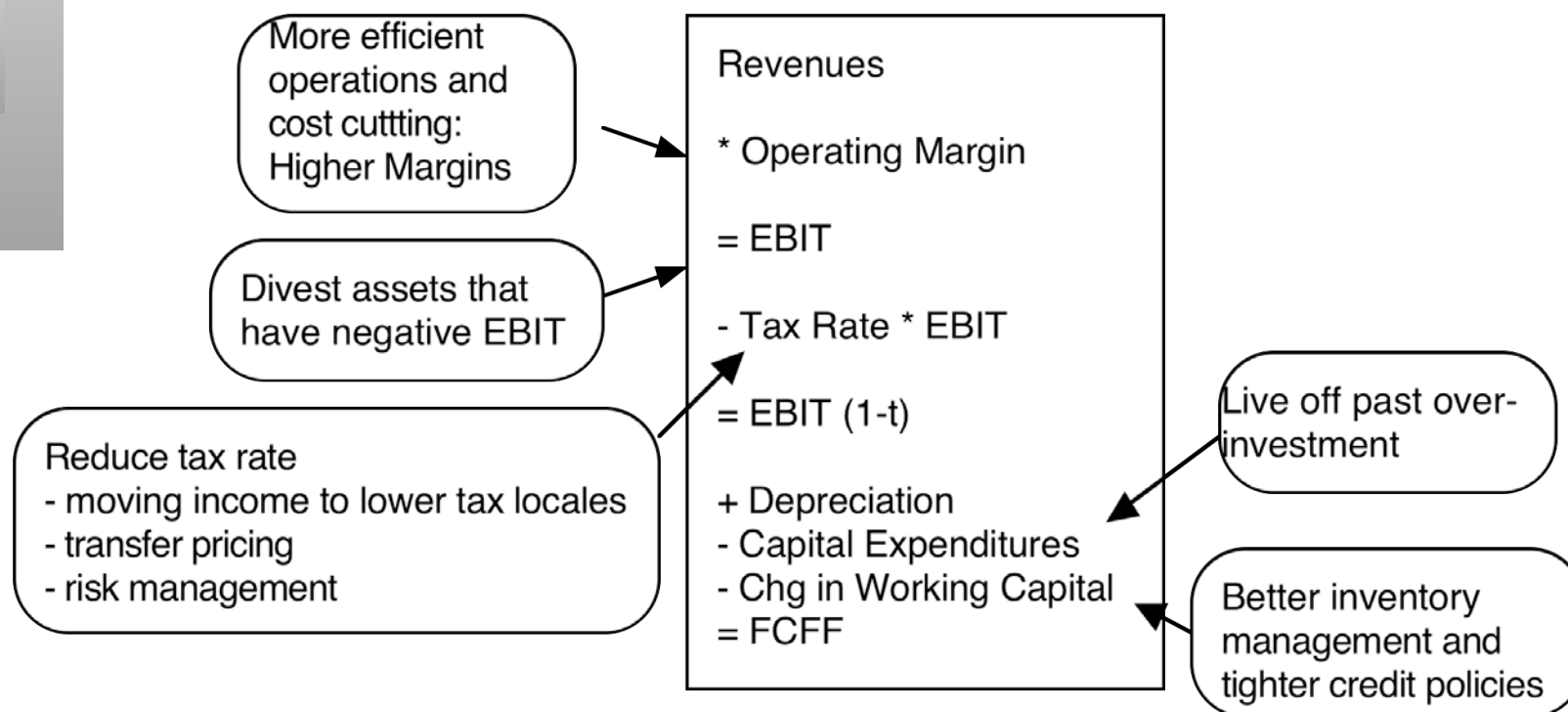

## Value Creation 2: Increase Expected Growth

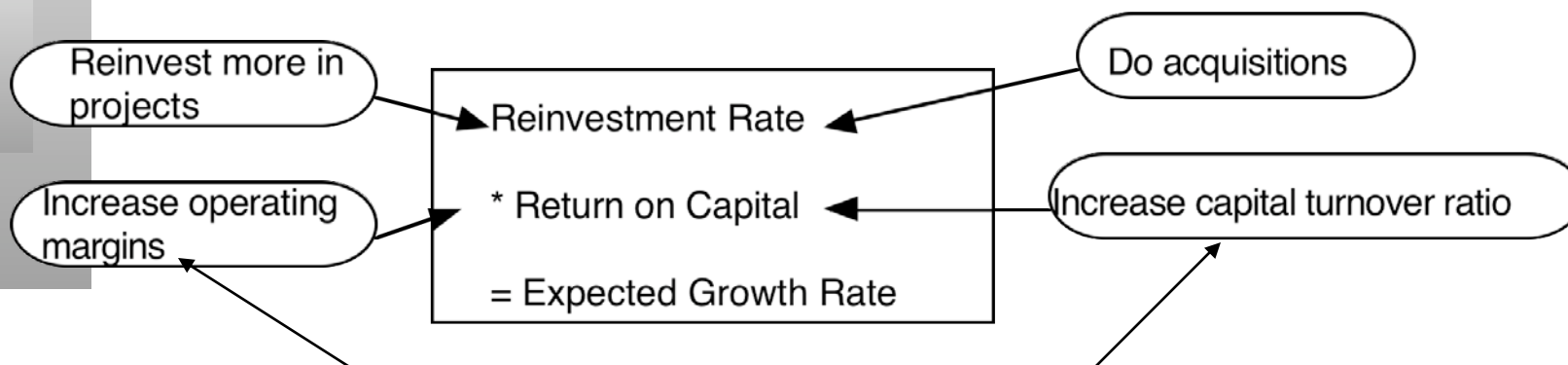

*Price Leader versus Volume Leader Strategies*  
*Return on Capital = Operating Margin \* Capital Turnover Ratio*

# Value Creating Growth... Evaluating the Alternatives..

## Modes of organic growth vary in value creation intensity— consumer goods industry

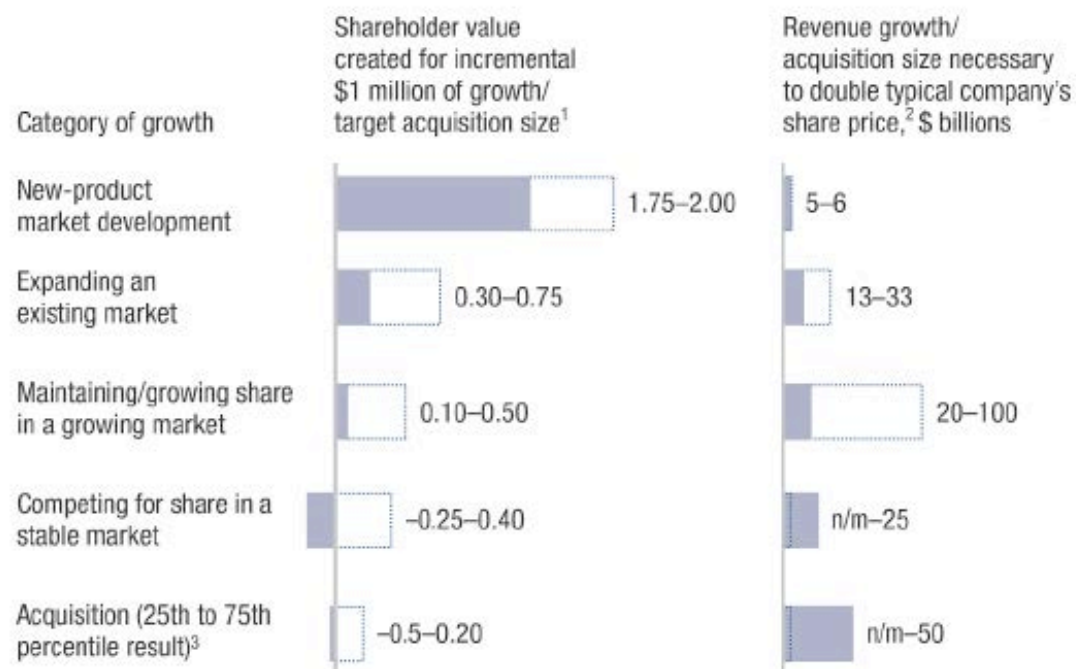



### III. Building Competitive Advantages: Increase length of the growth period

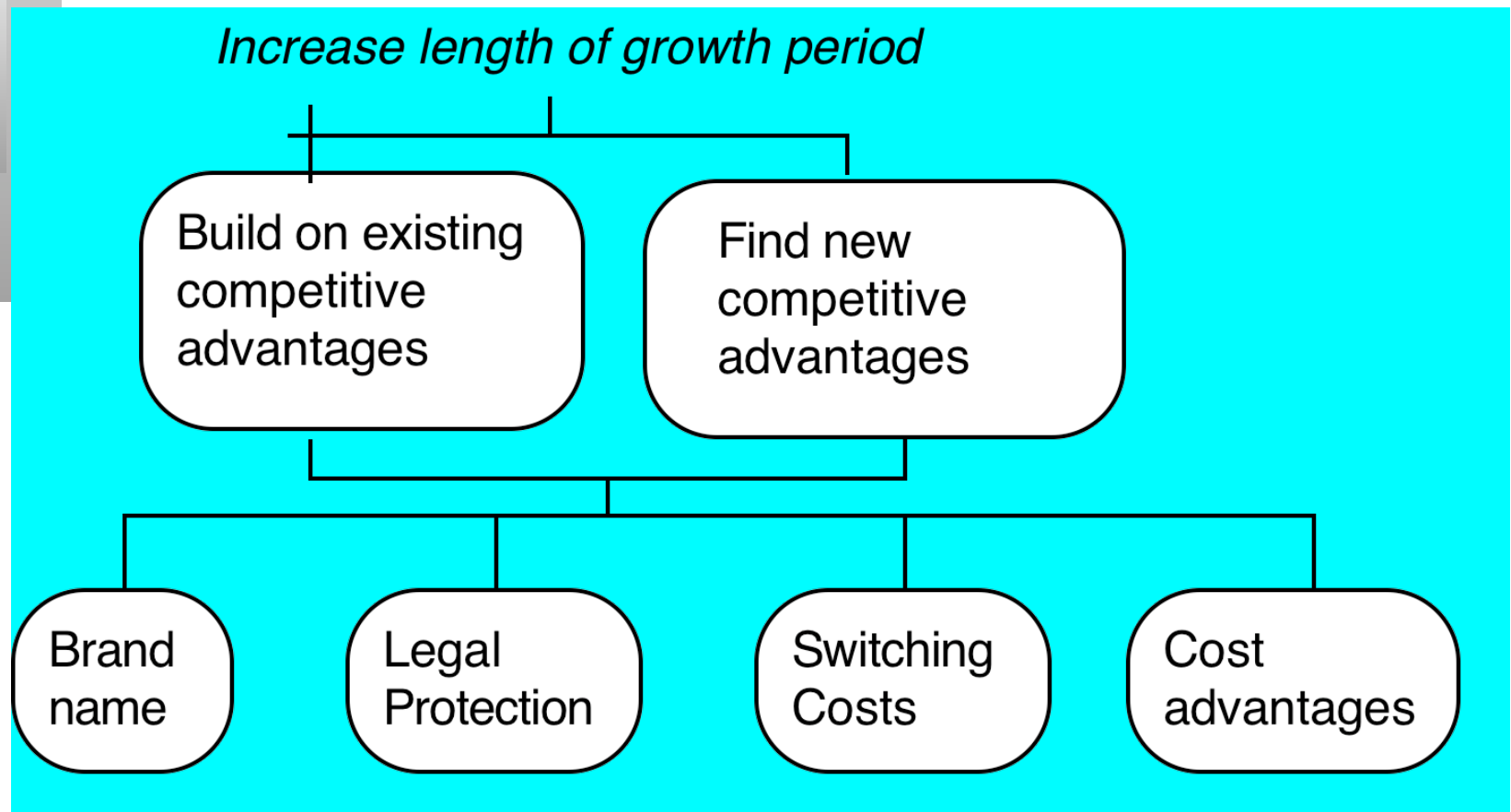

## Value Creation 4: Reduce Cost of Capital

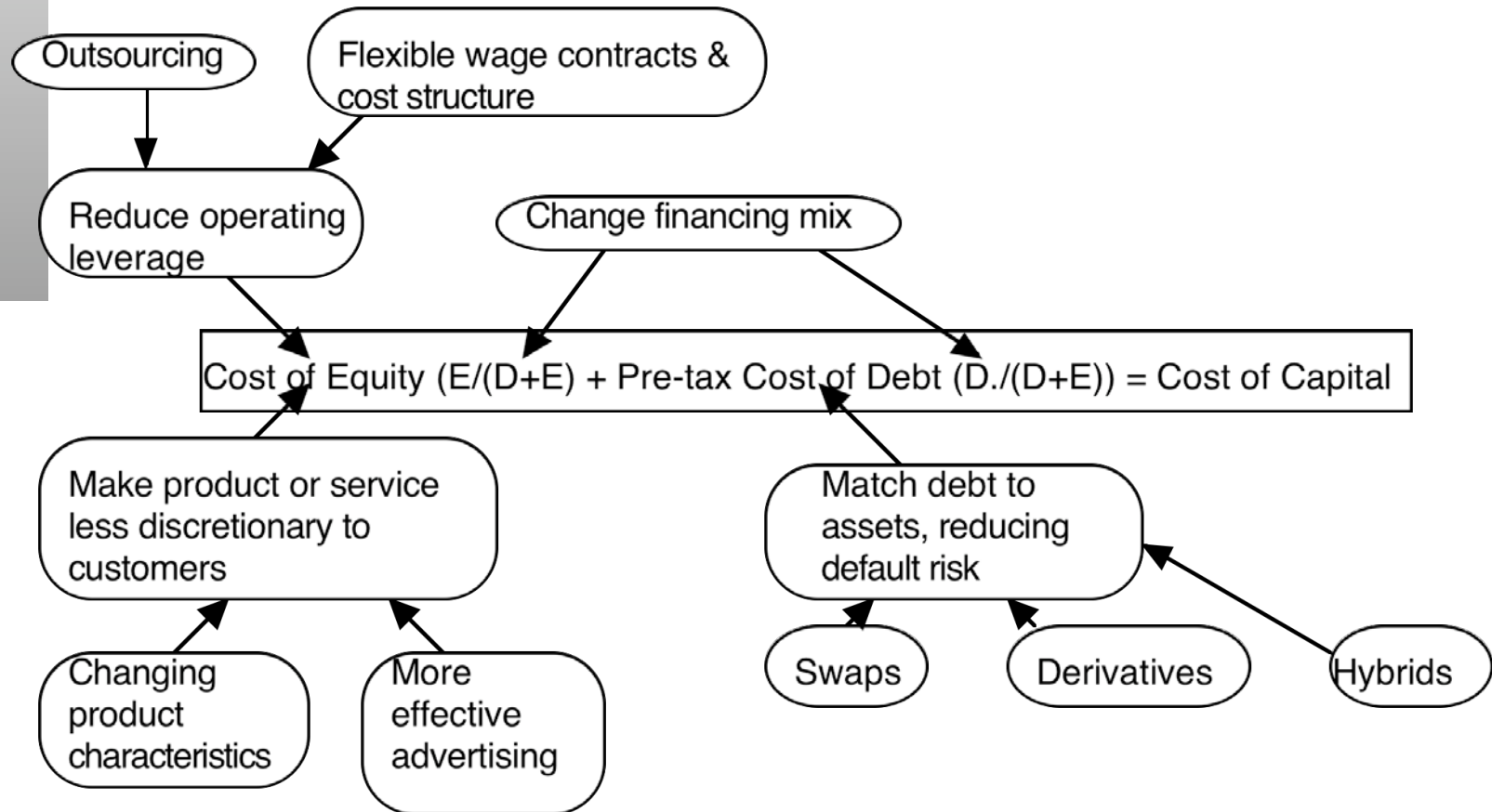

## Hyundai's Optimal Financing Mix

Debt Ratio	Beta	Cost of Equity	Bond Rating	Interest rate on debt	Tax Rate	Cost of Debt (after-tax)	WACC	Firm Value (G)
0%	1.49	11.27%	AAA	6.55%	27.50%	4.75%	11.27%	\$26,470
10%	1.61	11.77%	A	7.60%	27.50%	5.51%	11.15%	\$27,021
20%	1.76	12.41%	B	12.30%	27.50%	8.92%	11.71%	\$24,648
30%	1.96	13.23%	CC	17.30%	27.04%	12.62%	13.05%	\$20,313
40%	2.30	14.66%	C	18.50%	18.90%	15.00%	14.80%	\$16,437
50%	2.76	16.59%	C	18.50%	15.12%	15.70%	16.15%	\$14,278
60%	3.47	19.57%	D	19.80%	11.74%	17.48%	18.31%	\$11,727
70%	4.63	24.43%	D	19.80%	10.06%	17.81%	19.79%	\$10,414
80%	6.94	34.14%	D	19.80%	8.80%	18.06%	21.27%	\$9,340
90%	13.88	63.28%	D	19.80%	7.83%	18.25%	22.75%	\$8,445

---

## IV. Loose Ends in Valuation: From firm value to value of equity per share

## But what comes next?

<b>Value of Operating Assets</b>	Since this is a discounted cashflow valuation, should there be a real option premium?
<b>+ Cash and Marketable Securities</b>	Operating versus Non-operating cash Should cash be discounted for earning a low return?
<b>+ Value of Cross Holdings</b>	How do you value cross holdings in other companies? What if the cross holdings are in private businesses?
<b>+ Value of Other Assets</b>	What about other valuable assets? How do you consider under utilized assets?
<b>Value of Firm</b>	Should you discount this value for opacity or complexity? How about a premium for synergy? What about a premium for intangibles (brand name)?
<b>- Value of Debt</b>	What should be counted in debt? Should you subtract book or market value of debt? What about other obligations (pension fund and health care)? What about contingent liabilities? What about minority interests?
<b>= Value of Equity</b>	Should there be a premium/discount for control? Should there be a discount for distress
<b>- Value of Equity Options</b>	What equity options should be valued here (vested versus non-vested)? How do you value equity options?
<b>= Value of Common Stock</b>	Should you divide by primary or diluted shares?
<b>/ Number of shares</b>	
<b>= Value per share</b>	Should there be a discount for illiquidity/ marketability? Should there be a discount for minority interests?

## 1. An Exercise in Cash Valuation

---

	<i>Company A</i>	<i>Company B</i>	<i>Company C</i>
Enterprise Value	\$ 1 billion	\$ 1 billion	\$ 1 billion
Cash	\$ 100 mil	\$ 100 mil	\$ 100 mil
Return on Capital	10%	5%	22%
Cost of Capital	10%	10%	12%
Trades in	US	US	Indonesia

# Cash: Discount or Premium?

*Market Value of \$ 1 in cash:  
Estimates obtained by regressing Enterprise Value against Cash Balances*

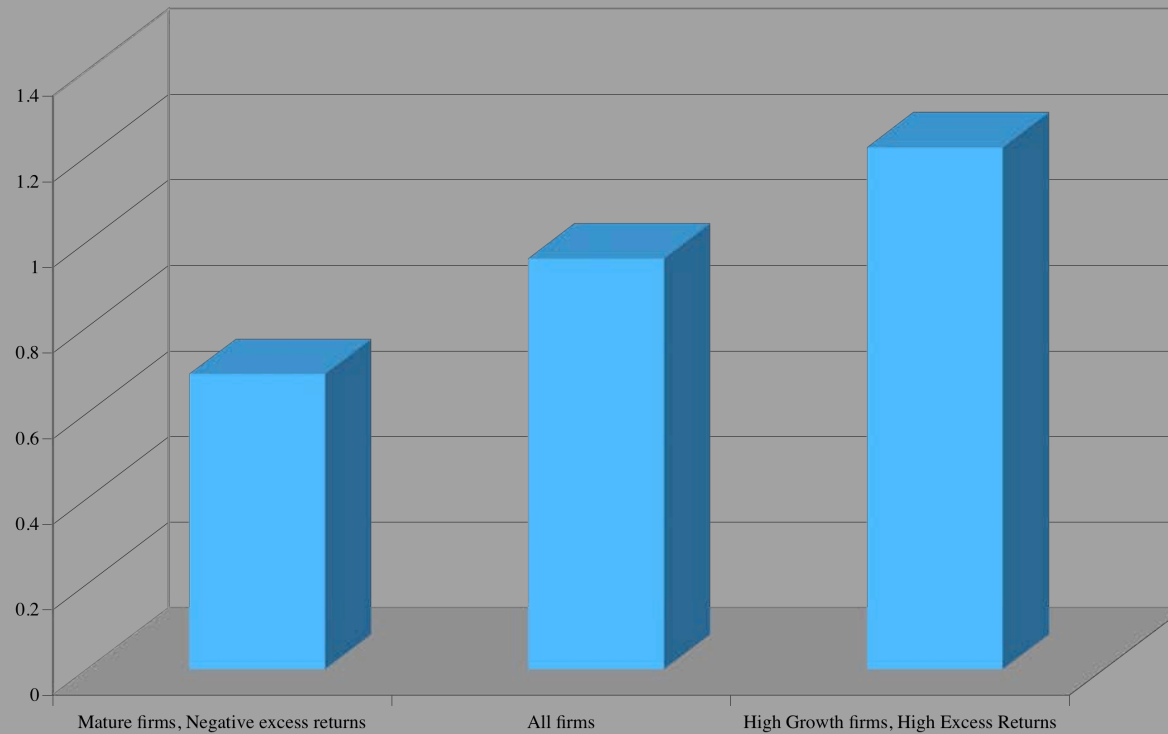

## Cash and Trouble?

<b>Company Name</b>	<b>Primary Industry</b>	<b>ROIC</b>	<b>Cash/ Value</b>
Able C&C Co. Ltd.	Personal Products	0.49%	38.74%
Varo Vision Co Ltd	-	0.85%	76.99%
Raygen Co. Ltd.	Semiconductors	1.12%	38.39%
Kodicom Co. Ltd.	Consumer Electronics	2.62%	53.35%
Kukyong Glass Industries	Building Products	3.10%	38.75%
DASAN Networks Inc.	Communications Equipment	3.45%	49.05%
Tellord Co. Ltd.	-	6.89%	45.47%
FRTEK Co. Ltd	Communications Equipment	6.98%	45.51%
Ilsung Construction Co., Ltd.	Construction and Engineering	7.29%	89.49%
H&T Co., Ltd.	Computer Storage and Peripherals	7.76%	42.92%
Feelingk Co. Ltd.	Internet Software and Services	8.38%	46.79%
Duck Yang Industry Co. Ltd.	Auto Parts and Equipment	8.84%	92.63%
Sewoo Global Co. Ltd.	Commodity Chemicals	9.23%	43.88%
D&T, Inc.	IT Consulting and Other Services	9.51%	39.31%



## 2. Dealing with Holdings in Other firms

---

- Holdings in other firms can be categorized into
  - Minority passive holdings, in which case only the dividend from the holdings is shown in the balance sheet
  - Minority active holdings, in which case the share of equity income is shown in the income statements
  - Majority active holdings, in which case the financial statements are consolidated.
- We tend to be sloppy in practice in dealing with cross holdings. After valuing the operating assets of a firm, using consolidated statements, it is common to add on the balance sheet value of minority holdings (which are in book value terms) and subtract out the minority interests (again in book value terms), representing the portion of the consolidated company that does not belong to the parent company.

## How to value holdings in other firms.. In a perfect world..

---

- In a perfect world, we would strip the parent company from its subsidiaries and value each one separately. The value of the combined firm will be
  - Value of parent company + Proportion of value of each subsidiary
- To do this right, you will need to be provided detailed information on each subsidiary to estimated cash flows and discount rates.

## Two compromise solutions...

---

- The market value solution: When the subsidiaries are publicly traded, you could use their traded market capitalizations to estimate the values of the cross holdings. You do risk carrying into your valuation any mistakes that the market may be making in valuation.
- The relative value solution: When there are too many cross holdings to value separately or when there is insufficient information provided on cross holdings, you can convert the book values of holdings that you have on the balance sheet (for both minority holdings and minority interests in majority holdings) by using the average price to book value ratio of the sector in which the subsidiaries operate.

## Hyundai's Cross Holdings

Public

Private

<i>Cross holding</i>	<i>% of holding</i>	<i>Total Market Cap</i>	<i>Value of holding</i>	<i>Book Value</i>	<i>P/Book (Sector)</i>
Hyundai Merchant Marine	17.60%	4806.00	845.86		
Hyundai Motors	3.46%	17540.00	606.88		
Hyundai Elevator	2.16%	688.00	14.86		
Hyundai Corp	0.36%	602.00	2.17		
Others	?	?	84.20		
Hyundai Oil Bank	19.87%	1825.77	362.78	329.80	1.10
Hyundai Samho	94.92%	2026.23	1923.30	1068.50	1.80
Hyundai Finance	67.49%	143.75	97.02	88.20	1.10
<b>Value of Cross holdings</b>			<b>3937.07</b>		

### 3. Other Assets that have not been counted yet..

---

- **Unutilized assets:** If you have assets or property that are not being utilized (vacant land, for example), you have not valued it yet. You can assess a market value for these assets and add them on to the value of the firm.
  - **Overfunded pension plans:** If you have a defined benefit plan and your assets exceed your expected liabilities, you could consider the over funding with two caveats:
    - Collective bargaining agreements may prevent you from laying claim to these excess assets.
    - There are tax consequences. Often, withdrawals from pension plans get taxed at much higher rates.
- Do not double count an asset. If you count the income from an asset in your cashflows, you cannot count the market value of the asset in your value.

## 4. A Discount for Complexity: An Experiment

---

	<i>Company A</i>	<i>Company B</i>
Operating Income	\$ 1 billion	\$ 1 billion
Tax rate	40%	40%
ROIC	10%	10%
Expected Growth	5%	5%
Cost of capital	8%	8%
Business Mix	Single Business	Multiple Businesses
Holdings	Simple	Complex
Accounting	Transparent	Opaque

- *Which firm would you value more highly?*

## Measuring Complexity: Volume of Data in Financial Statements

<i>Company</i>	<i>Number of pages in last 10Q</i>	<i>Number of pages in last 10K</i>
General Electric	65	410
Microsoft	63	218
Wal-mart	38	244
Exxon Mobil	86	332
Pfizer	171	460
Citigroup	252	1026
Intel	69	215
AIG	164	720
Johnson & Johnson	63	218
IBM	85	353

## Measuring Complexity: A Complexity Score

Item	Factors	Follow-up Question	Answer	Weighting factor	Gerdau Score	GE Score
Operating Income	1. Multiple Businesses	Number of businesses (with more than 10% of revenues) =	1	2.00	2	30
	2. One-time income and expenses	Percent of operating income =	10%	10.00	1	0.8
	3. Income from unspecified sources	Percent of operating income =	0%	10.00	0	1.2
	4. Items in income statement that are volatile	Percent of operating income =	15%	5.00	0.75	1
Tax Rate	1. Income from multiple locales	Percent of revenues from non-domestic locales =	70%	3.00	2.1	1.8
	2. Different tax and reporting books	Yes or No	No	Yes=3	0	3
	3. Headquarters in tax havens	Yes or No	No	Yes=3	0	0
	4. Volatile effective tax rate	Yes or No	Yes	Yes=2	2	0
Capital Expenditures	1. Volatile capital expenditures	Yes or No	Yes	Yes=2	2	2
	2. Frequent and large acquisitions	Yes or No	Yes	Yes=4	4	4
	3. Stock payment for acquisitions and investments	Yes or No	No	Yes=4	0	4
Working capital	1. Unspecified current assets and current liabilities	Yes or No	No	Yes=3	0	0
	2. Volatile working capital items	Yes or No	Yes	Yes=2	2	2
Expected Growth rate	1. Off-balance sheet assets and liabilities (operating leases and R&D)	Yes or No	No	Yes=3	0	3
	2. Substantial stock buybacks	Yes or No	No	Yes=3	0	3
	3. Changing return on capital over time	Is your return on capital volatile?	Yes	Yes=5	5	5
	4. Unsustainably high return	Is your firm's ROC much higher than industry average?	No	Yes=5	0	0
Cost of capital	1. Multiple businesses	Number of businesses (more than 10% of revenues) =	1	1.00	1	20
	2. Operations in emerging markets	Percent of revenues=	50%	5.00	2.5	2.5
	3. Is the debt market traded?	Yes or No	No	No=2	2	0
	4. Does the company have a rating?	Yes or No	Yes	No=2	0	0
	5. Does the company have off-balance sheet debt?	Yes or No	No	Yes=5	0	5
No-operating assets	Minority holdings as percent of book assets	Minority holdings as percent of book assets	0%	20.00	0	0.8
Firm to Equity value	Consolidation of subsidiaries	Minority interest as percent of book value of equity	63%	20.00	12.6	1.2
Per share value	Shares with different voting rights	Does the firm have shares with different voting rights?	Yes	Yes = 10	10	0
	Equity options outstanding	Options outstanding as percent of shares	0%	10.00	0	0.25
Complexity Score =					48.95	90.55



# Hyundai: An Enigma wrapped in a Mystery

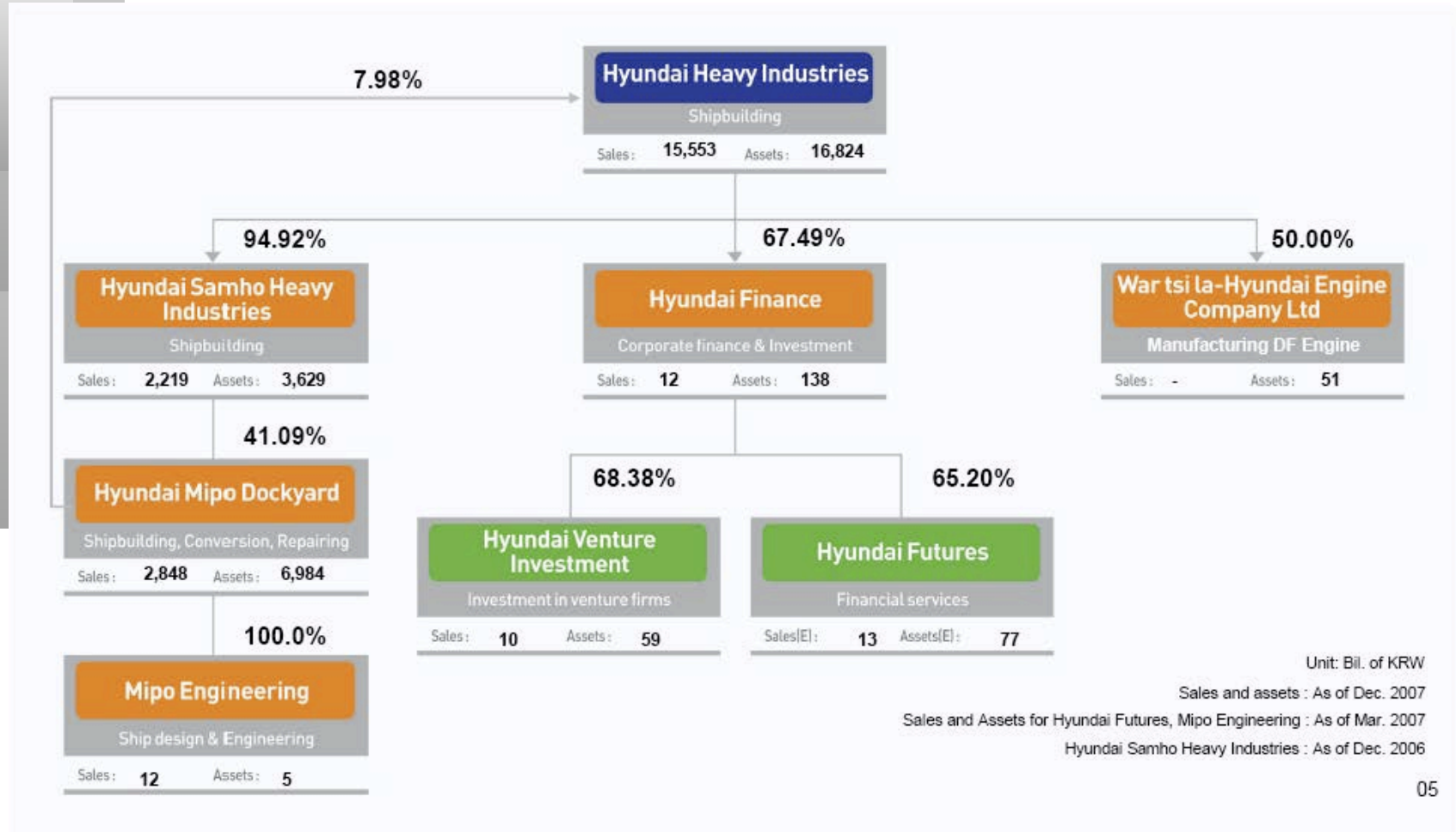

05

# Dealing with Complexity

---

## In Discounted Cashflow Valuation

- The Aggressive Analyst: Trust the firm to tell the truth and value the firm based upon the firm's statements about their value.
- The Conservative Analyst: Don't value what you cannot see.
- The Compromise: Adjust the value for complexity
  - Adjust cash flows for complexity
  - Adjust the discount rate for complexity
  - Adjust the expected growth rate/ length of growth period
  - Value the firm and then discount value for complexity

## In relative valuation

In a relative valuation, you may be able to assess the price that the market is charging for complexity:

With the hundred largest market cap firms, for instance:

$PBV = 0.65 + 15.31 \text{ ROE} - 0.55 \text{ Beta} + 3.04 \text{ Expected growth rate} - 0.003 \text{ # Pages in 10K}$

## 5. The Value of Synergy

---

- Synergy can be valued. In fact, if you want to pay for it, it should be valued.
- To value synergy, you need to answer two questions:
  - (a) What **form** is the synergy expected to take? Will it **reduce costs** as a percentage of sales and increase profit margins (as is the case when there are economies of scale)? Will it **increase future growth** (as is the case when there is increased market power)? )
  - (b) **When can the synergy be reasonably expected to start** affecting cashflows? (Will the gains from synergy show up instantaneously after the takeover? If it will take time, when can the gains be expected to start showing up? )
- If you cannot answer these questions, you need to go back to the drawing board...

# Sources of Synergy

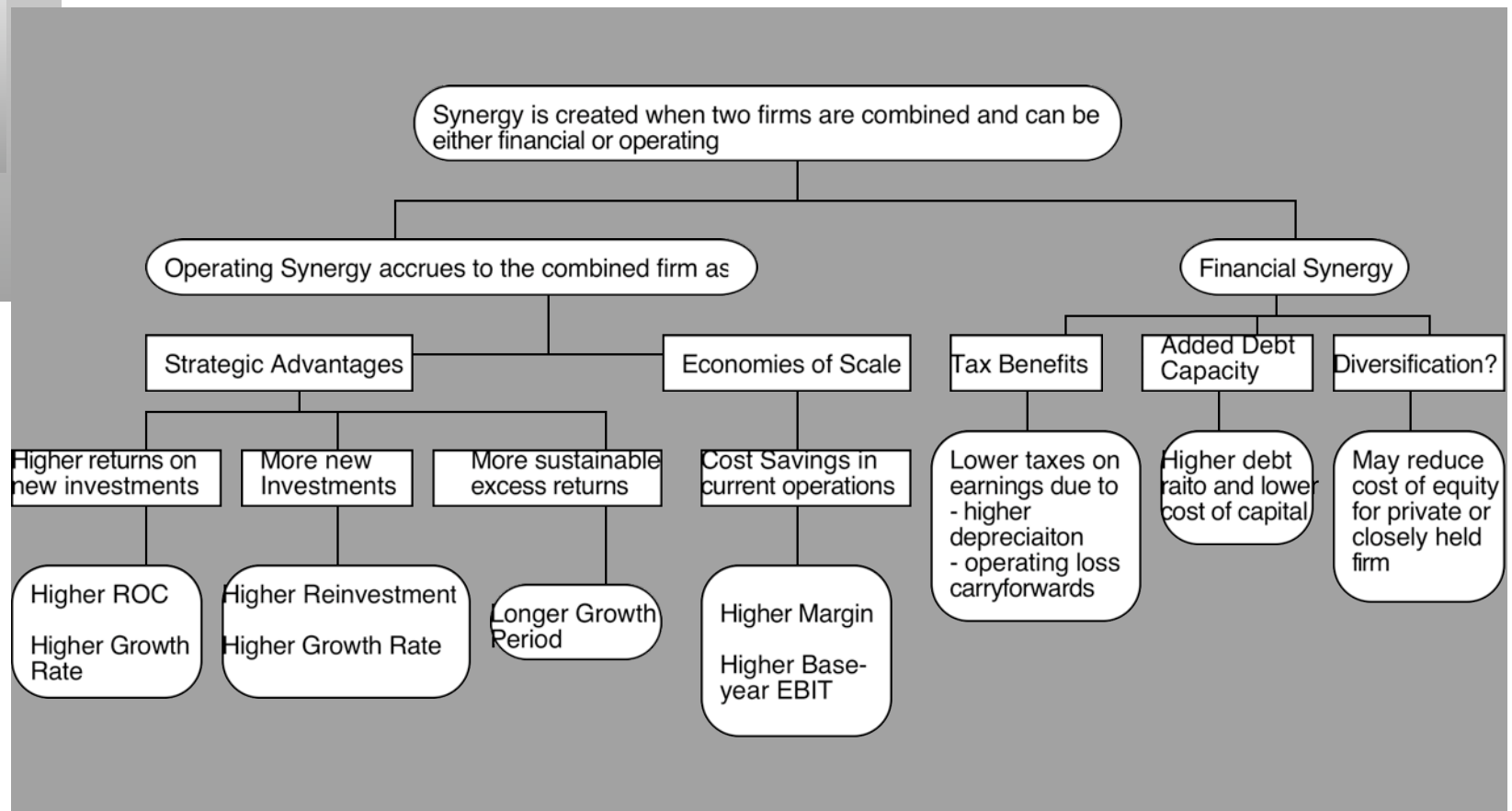

## Valuing Synergy

---

- (1) the firms involved in the merger are **valued independently**, by discounting expected cash flows to each firm at the weighted average cost of capital for that firm.
- (2) the **value of the combined firm, with no synergy**, is obtained by adding the values obtained for each firm in the first step.
- (3) The **effects of synergy are built into expected growth rates and cashflows**, and the combined firm is re-valued with synergy.

Value of Synergy = Value of the combined firm, with synergy - Value of the combined firm, without synergy

## Valuing Synergy: P&G + Gillette

	P&G	Gillette	Piglet: No Synergy	Piglet: Synergy	
Free Cashflow to Equity	\$5,864.74	\$1,547.50	\$7,412.24	\$7,569.73	Annual operating expenses reduced by \$250 million
Growth rate for first 5 years	12%	10%	11.58%	12.50%	Slightly higher growth rate
Growth rate after five years	4%	4%	4.00%	4.00%	
Beta	0.90	0.80	0.88	0.88	
Cost of Equity	7.90%	7.50%	7.81%	7.81%	Value of synergy
Value of Equity	\$221,292	\$59,878	\$281,170	\$298,355	<b>\$17,185</b>

## 6. Brand name, great management, superb product ...Are we short changing the intangibles?

---

- There is often a temptation to add on premiums for intangibles. Among them are
  - Brand name
  - Great management
  - Loyal workforce
  - Technological prowess
- There are two potential dangers:
  - For some assets, the value may already be in your value and adding a premium will be double counting.
  - For other assets, the value may be ignored but incorporating it will not be easy.

## Categorizing Intangibles

	<i>Independent and Cash flow generating intangibles</i>	<i>Not independent and cash flow generating to the firm</i>	<i>No cash flows now but potential for cashflows in future</i>
Examples	Copyrights, trademarks, licenses, franchises, professional practices (medical, dental)	Brand names, Quality and Morale of work force, Technological expertise, Corporate reputation	Undeveloped patents, operating or financial flexibility (to expand into new products/markets or abandon existing ones)
Valuation approach	Estimate expected cashflows from the product or service and discount back at appropriate discount rate.	<ul style="list-style-type: none"> <li>• Compare DCF value of firm with intangible with firm without (if you can find one)</li> <li>• Assume that all excess returns of firm are due to intangible.</li> <li>• Compare multiples at which firm trades to sector averages.</li> </ul>	Option valuation <ul style="list-style-type: none"> <li>• Value the undeveloped patent as an option to develop the underlying product.</li> <li>• Value expansion options as call options</li> <li>• Value abandonment options as put options.</li> </ul>
Challenges	<ul style="list-style-type: none"> <li>• Life is usually finite and terminal value may be small.</li> <li>• Cashflows and value may be person dependent (for professional practices)</li> </ul>	With multiple intangibles (brand name and reputation for service), it becomes difficult to break down individual components.	<ul style="list-style-type: none"> <li>• Need exclusivity.</li> <li>• Difficult to replicate and arbitrage (making option pricing models dicey)</li> </ul>



## Valuing Brand Name

---

	Coca Cola	With Cott Margins
Current Revenues =	\$21,962.00	\$21,962.00
Length of high-growth period	10	10
Reinvestment Rate =	50%	50%
Operating Margin (after-tax)	15.57%	5.28%
Sales/Capital (Turnover ratio)	1.34	1.34
Return on capital (after-tax)	20.84%	7.06%
Growth rate during period (g) =	10.42%	3.53%
Cost of Capital during period =	7.65%	7.65%
Stable Growth Period		
Growth rate in steady state =	4.00%	4.00%
Return on capital =	7.65%	7.65%
Reinvestment Rate =	52.28%	52.28%
Cost of Capital =	7.65%	7.65%
<b>Value of Firm =</b>	<b>\$79,611.25</b>	<b>\$15,371.24</b>

## 7. Be circumspect about defining debt for cost of capital purposes...

---

- **General Rule:** Debt generally has the following characteristics:
  - Commitment to make fixed payments in the future
  - The fixed payments are tax deductible
  - Failure to make the payments can lead to either default or loss of control of the firm to the party to whom payments are due.
- Defined as such, debt should include
  - All interest bearing liabilities, short term as well as long term
  - All leases, operating as well as capital
- Debt should not include
  - Accounts payable or supplier credit

## Book Value or Market Value

---

- For some firms that are in financial trouble, the book value of debt can be substantially higher than the market value of debt. Analysts worry that subtracting out the market value of debt in this case can yield too high a value for equity.
- A discounted cashflow valuation is designed to value a going concern. In a going concern, it is the market value of debt that should count, even if it is much lower than book value.
- In a liquidation valuation, you can subtract out the book value of debt from the liquidation value of the assets.

Converting book debt into market debt,,,,,

## But you should consider other potential liabilities when getting to equity value

---

- If you have under funded pension fund or health care plans, you should consider the under funding at this stage in getting to the value of equity.
  - If you do so, you should not double count by also including a cash flow line item reflecting cash you would need to set aside to meet the unfunded obligation.
  - You should not be counting these items as debt in your cost of capital calculations....
- If you have contingent liabilities - for example, a potential liability from a lawsuit that has not been decided - you should consider the expected value of these contingent liabilities
  - Value of contingent liability = Probability that the liability will occur \* Expected value of liability

## 8. The Value of Control

---

- The value of the control premium that will be paid to acquire a block of equity will depend upon two factors -
  - **Probability that control of firm will change:** This refers to the probability that incumbent management will be replaced. this can be either through acquisition or through existing stockholders exercising their muscle.
  - **Value of Gaining Control of the Company:** The value of gaining control of a company arises from two sources - the increase in value that can be wrought by changes in the way the company is managed and run, and the side benefits and perquisites of being in control

Value of Gaining Control = Present Value (Value of Company with change in control - Value of company without change in control) + Side Benefits of Control

# Hyundai Heavy: Status Quo (\$)

**Current Cashflow to Firm**  
 EBIT(1-t) : 1,269 Billion Won  
 - Nt CpX 519  
 - Chg WC 135  
 = FCFF 615  
 Reinvestment Rate = 654/1269=51.5%  
 Return on capital = 1269/3390 =37.45%

Reinvestment Rate  
50%

**Expected Growth in EBIT (1-t)**  
 $.50 * .30 = .15$   
**15%**

Return on Capital  
30%

Stable Growth  
 $g = 5\%$ ; Beta = 1.20;  
 Country Premium = 0.8%  
 Cost of capital = 9.42%  
 ROC = 9.42%  
 Reinvestment Rate =  $g/ROC$   
 $= 5/9.42 = 53.1\%$

Terminal Value<sub>5</sub> =  $1258(.0942 - .05) = 28,471$

Wn Cashflows

Op. Assets 20,211  
 + Cash: 3,612  
 + Non-Op 3,937  
 - Debt 186  
 = Equity 27,574  
 - Options 0  
 Value/Share 362.82  
 (362,820 Won/Sh)

Year	1	2	3	4	5	Term Yr
EBIT (1-t)	1,460	1,679	1,931	2,220	2,553	2,681
- Reinvestment	730	839	965	1,110	1,277	1,423
FCFF	730	839	965	1,110	1,277	=1,258

Discount at \$ Cost of Capital (WACC) = 11.3% (.993) + 4.75% (0.007) = 11.26%

**Cost of Equity**  
11.30%

**Cost of Debt**  
 $(5\% + 0.8\% + 0.75\%)(1 - .275)$   
 = 4.75%

**Weights**  
 E = 99.3% D = 0.7%

On June 1, 2008  
 Hyundai Heavy traded at  
 350,000 Won/share.

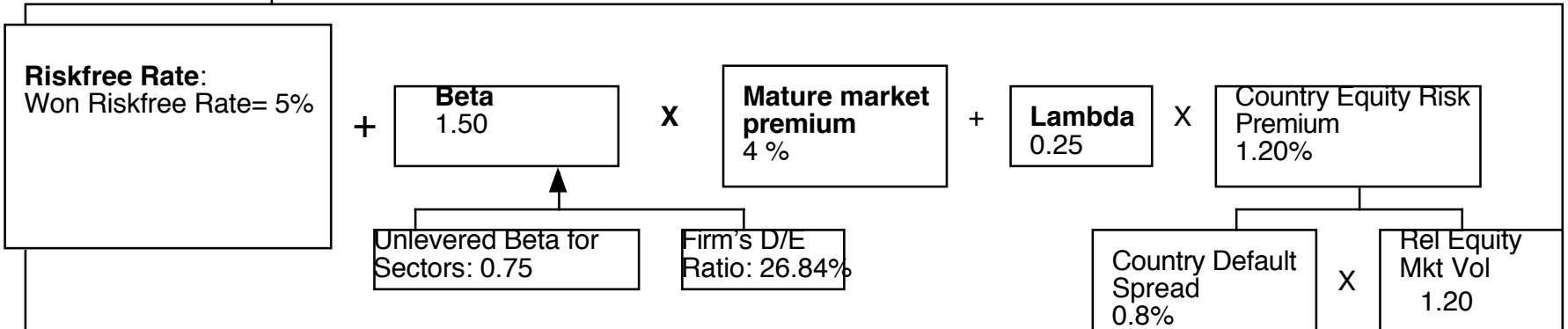

# Hyundai Heavy: Restructured(Won)

**Current Cashflow to Firm**  
 EBIT(1-t) : 1,269 Billion Won  
 - Nt CpX 519  
 - Chg WC 135  
 = FCFF 615  
 Reinvestment Rate = 654/1269=51.5%  
 Return on capital = 1269/3390 =37.45%

Reinvestment Rate  
50%

**Expected Growth in EBIT (1-t)**  
 $.50 \times .30 = .15$   
**15%**

Return on Capital  
30%

Stable Growth  
 $g = 5\%$ ; Beta = 1.20;  
 Country Premium = 0.8%  
 Cost of capital = 9.42%  
 ROC = 9.42%  
 Reinvestment Rate =  $g/ROC = 5/9.42 = 53.1\%$

Terminal Value<sub>5</sub> =  $1932 \times (.0942 - .05) = 43,732$

Wn Cashflows

Op. Assets 23,112  
 + Cash: 3,612  
 + Non-Op 3,937  
 - Debt 186  
 = Equity 30,481  
 - Options 0  
 Value/Share 401.06  
 (401,060 Won/Sh)

Year	1	2	3	4	5	6	7	8	9	10
EBIT (1-t)	1,460	1,679	1,931	2,220	2,553	2,885	3,203	3,491	3,735	3,922
- Reinvestment	730	839	965	1,110	1,277	1,461	1,641	1,810	1,960	2,082
FCFF	730	839	965	1,110	1,277	1,425	1,562	1,681	1,775	1,840

Term Yr  
4,118  
2,186  
=1,932

Discount at \$ Cost of Capital (WACC) =  $11.3\% (.9) + 4.75\% (0.1) = 11.16\%$

**Cost of Equity**  
11.74%

**Cost of Debt**  
 $(5\% + 0.8\% + 1.8\%) (1 - .275) = 5.51\%$

**Weights**  
E = 90% D = 10%

On June 1, 2008  
Hyundai Heavy traded at  
350,000 Won/share.

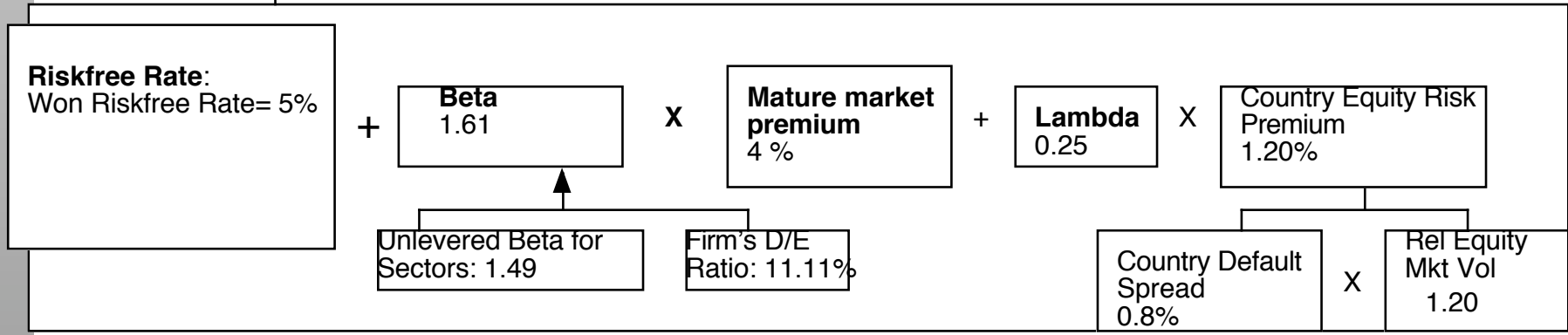

## The Value of Control in a publicly traded firm..

---

- If the value of a firm run optimally is significantly higher than the value of the firm with the status quo (or incumbent management), you can write the value that you should be willing to pay as:

Value of control = Value of firm optimally run - Value of firm with status quo

Value of control at Hyundai Heavy= 401 Won per share – 362 Won per share = 39 Won per share

- Implications:
  - In an acquisition, this is the most that you would be willing to pay as a premium (assuming no other synergy)
  - As a stockholder, you will be willing to pay a value between 362 and 401 Wn, depending upon your views on whether control will change.
  - If there are voting and non-voting shares, the difference in prices between the two should reflect the value of control.



## Minority and Majority interests in a private firm

---

- When you get a controlling interest in a private firm (generally  $>51\%$ , but could be less...), you would be willing to pay the appropriate proportion of the optimal value of the firm.
- When you buy a minority interest in a firm, you will be willing to pay the appropriate fraction of the status quo value of the firm.
- For badly managed firms, there can be a significant difference in value between  $51\%$  of a firm and  $49\%$  of the same firm. This is the minority discount.
- If you own a private firm and you are trying to get a private equity or venture capital investor to invest in your firm, it may be in your best interests to offer them a share of control in the firm even though they may have well below  $51\%$ .

## 9. Distress and the Going Concern Assumption

---

- Traditional valuation techniques are built on the assumption of a going concern, i.e., a firm that has continuing operations and there is no significant threat to these operations.
  - In discounted cashflow valuation, this going concern assumption finds its place most prominently in the terminal value calculation, which usually is based upon an infinite life and ever-growing cashflows.
  - In relative valuation, this going concern assumption often shows up implicitly because a firm is valued based upon how other firms - most of which are healthy - are priced by the market today.
- When there is a significant likelihood that a firm will not survive the immediate future (next few years), traditional valuation models may yield an over-optimistic estimate of value.

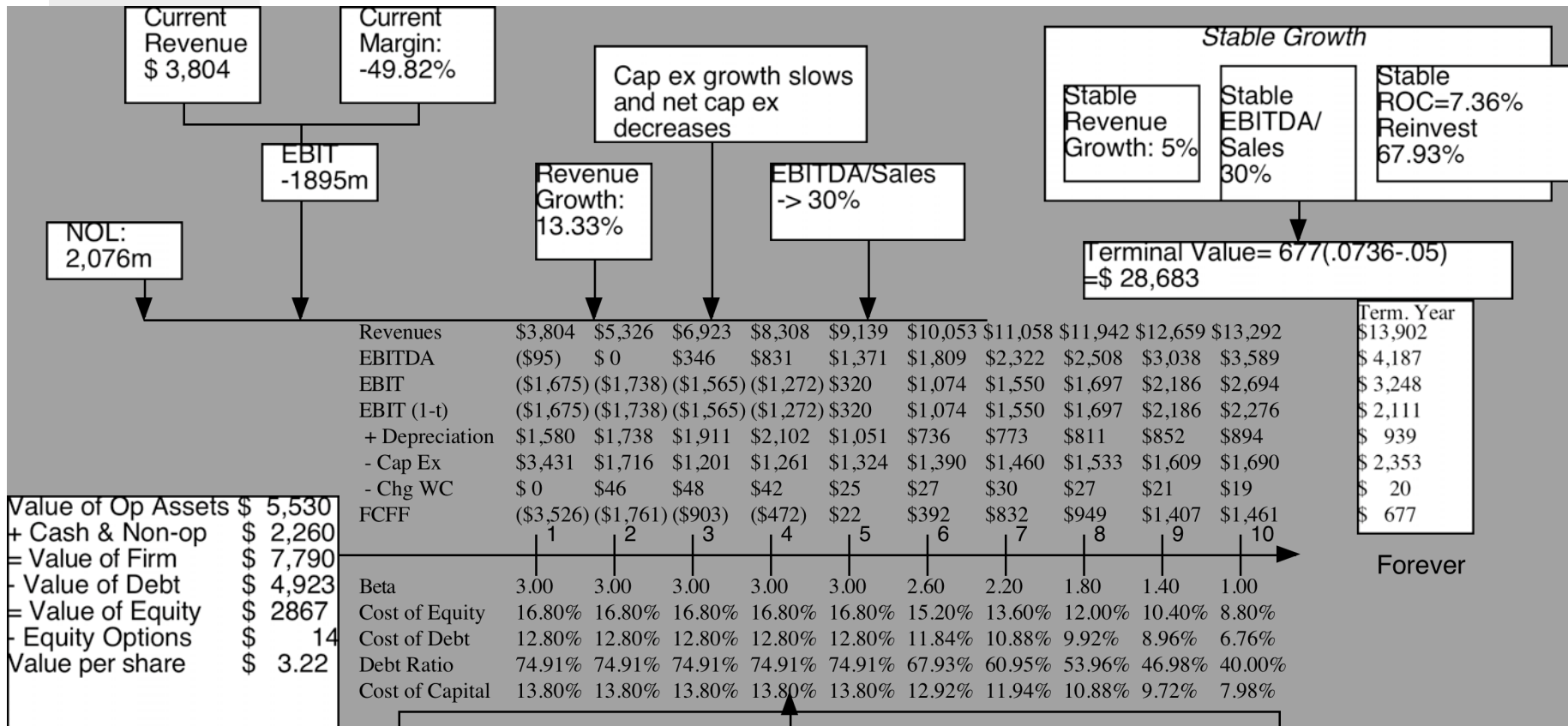

Value of Op Assets \$ 5,530  
 + Cash & Non-op \$ 2,260  
 = Value of Firm \$ 7,790  
 - Value of Debt \$ 4,923  
 = Value of Equity \$ 2,867  
 - Equity Options \$ 14  
 Value per share \$ 3.22

**Cost of Equity 16.80%**  
**Cost of Debt 4.8%+8.0%=12.8%**  
 Tax rate = 0% -> 35%  
**Weights Debt= 74.91% -> 40%**

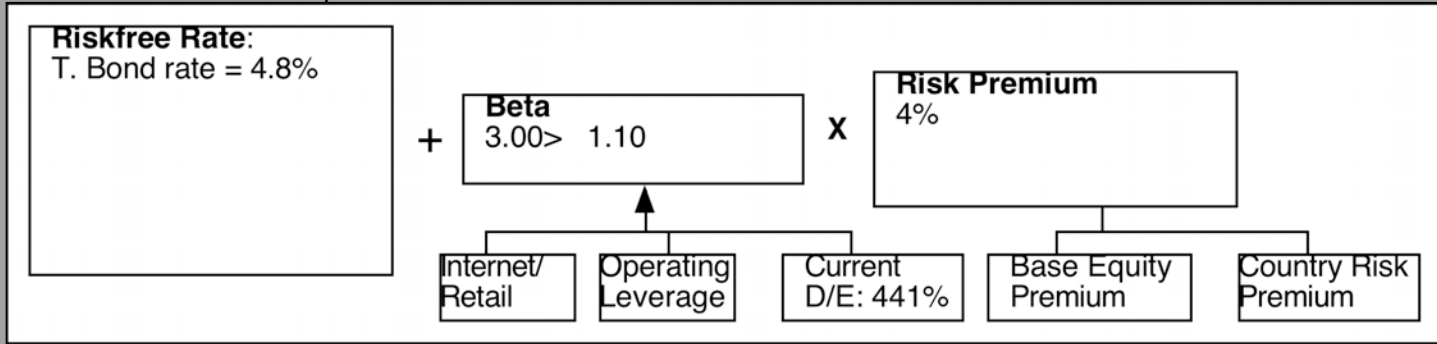

**Global Crossing**  
**November 2001**  
**Stock price = \$1.86**

## Valuing Global Crossing with Distress

### ■ Probability of distress

- Price of 8 year, 12% bond issued by Global Crossing = \$ 653

$$653 = \sum_{t=1}^{t=8} \frac{120(1 - \pi_{Distress})^t}{(1.05)^t} + \frac{1000(1 - \pi_{Distress})^8}{(1.05)^8}$$

- Probability of distress = 13.53% a year
- Cumulative probability of survival over 10 years =  $(1 - .1353)^{10} = 23.37\%$

### ■ Distress sale value of equity

- Book value of capital = \$14,531 million
- Distress sale value = 15% of book value =  $.15 * 14531 = \$2,180$  million
- Book value of debt = \$7,647 million
- Distress sale value of equity = \$ 0

### ■ Distress adjusted value of equity

- Value of Global Crossing =  $\$3.22 (.2337) + \$0.00 (.7663) = \$0.75$

## 10. Equity to Employees: Effect on Value

---

- In recent years, firms have turned to giving employees (and especially top managers) equity option packages as part of compensation. These options are usually
  - Long term
  - At-the-money when issued
  - On volatile stocks
- Are they worth money? And if yes, who is paying for them?
- Two key issues with employee options:
  - How do options granted in the past affect equity value per share today?
  - How do expected future option grants affect equity value today?

# Equity Options and Value

---

- Options outstanding
  - Step 1: List all options outstanding, with maturity, exercise price and vesting status.
  - Step 2: Value the options, taking into account dilution, vesting and early exercise considerations
  - Step 3: Subtract from the value of equity and divide by the actual number of shares outstanding (not diluted or partially diluted).
- Expected future option and restricted stock issues
  - Step 1: Forecast value of options that will be granted each year as percent of revenues that year. (As firm gets larger, this should decrease)
  - Step 2: Treat as operating expense and reduce operating income and cash flows
  - Step 3: Take present value of cashflows to value operations or equity.

## 11. Analyzing the Effect of Illiquidity on Value

---

- Investments which are less liquid should trade for less than otherwise similar investments which are more liquid.
- The size of the illiquidity discount should depend upon
  - *Type of Assets owned by the Firm*: The more liquid the assets owned by the firm, the lower should be the liquidity discount for the firm
  - *Size of the Firm*: The larger the firm, the smaller should be size of the liquidity discount.
  - *Health of the Firm*: Stock in healthier firms should sell for a smaller discount than stock in troubled firms.
  - *Cash Flow Generating Capacity*: Securities in firms which are generating large amounts of cash from operations should sell for a smaller discounts than securities in firms which do not generate large cash flows.
  - *Size of the Block*: The liquidity discount should increase with the size of the portion of the firm being sold.

## Illiquidity Discount: Restricted Stock Studies

---

- Restricted securities are securities issued by a company, but not registered with the SEC, that can be sold through private placements to investors, but cannot be resold in the open market for a two-year holding period, and limited amounts can be sold after that. Studies of restricted stock over time have concluded that the discount is between 25 and 35%. Many practitioners use this as the illiquidity discount for all private firms.
- A more nuanced use of restricted stock studies is to relate the discount to fundamental characteristics of the company - level of revenues, health of the company etc.. And to adjust the discount for any firm to reflect its characteristics:
  - The discount will be smaller for larger firms
  - The discount will be smaller for healthier firms



## Illiquidity Discounts from Bid-Ask Spreads

---

- Using data from the end of 2000, for instance, we regressed the bid-ask spread against annual revenues, a dummy variable for positive earnings (DERN: 0 if negative and 1 if positive), cash as a percent of firm value and trading volume.

$$\text{Spread} = 0.145 - 0.0022 \ln(\text{Annual Revenues}) - 0.015 (\text{DERN}) - 0.016 (\text{Cash}/\text{Firm Value}) - 0.11 (\text{\$ Monthly trading volume}/\text{Firm Value})$$

- We could substitute in the revenues of Kristin Kandy (\$5 million), the fact that it has positive earnings and the cash as a percent of revenues held by the firm (8%):

$$\text{Spread} = 0.145 - 0.0022 \ln(\text{Annual Revenues}) - 0.015 (\text{DERN}) - 0.016 (\text{Cash}/\text{Firm Value}) - 0.11 (\text{\$ Monthly trading volume}/\text{Firm Value})$$

$$= 0.145 - 0.0022 \ln(5) - 0.015(1) - 0.016(.08) - 0.11(0) = .1252\%$$

- Based on this approach, we would estimate an illiquidity discount of 12.52% for Kristin Kandy.

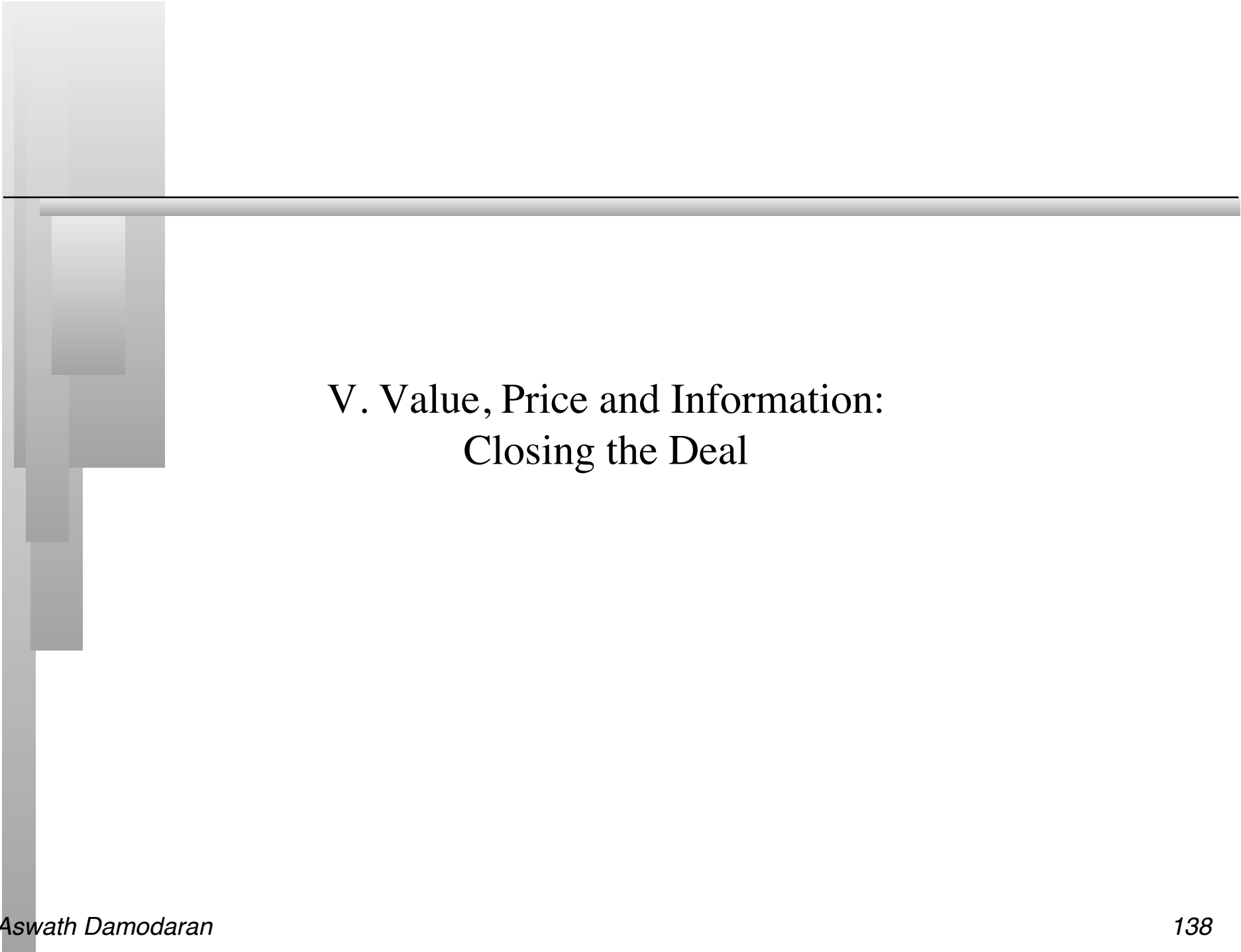

## V. Value, Price and Information: Closing the Deal

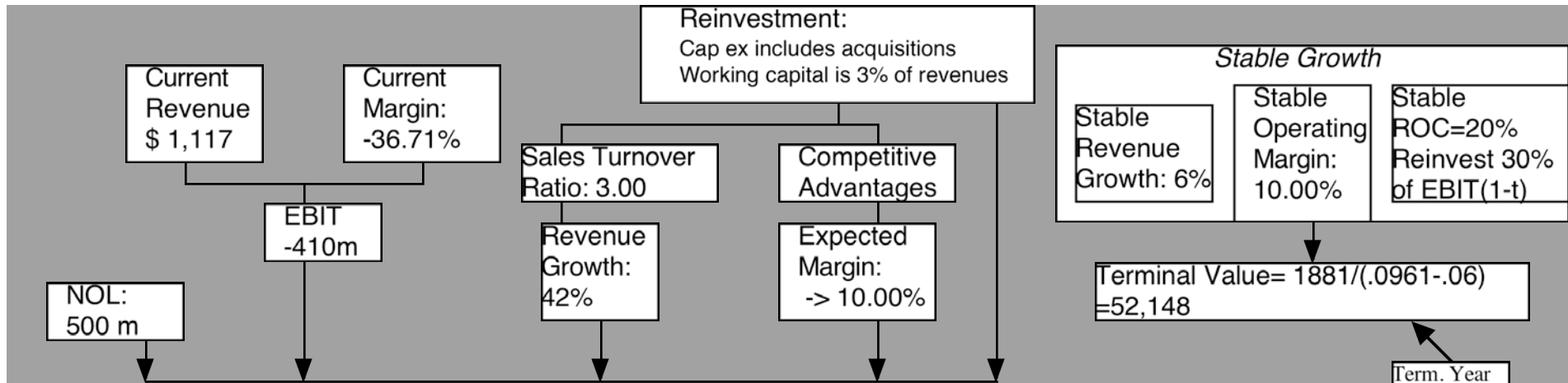

Revenues	\$2,793	5,585	9,774	14,661	19,059	23,862	28,729	33,211	36,798	39,006
EBIT	-\$373	-\$94	\$407	\$1,038	\$1,628	\$2,212	\$2,768	\$3,261	\$3,646	\$3,883
EBIT (1-t)	-\$373	-\$94	\$407	\$871	\$1,058	\$1,438	\$1,799	\$2,119	\$2,370	\$2,524
- Reinvestment	\$559	\$931	\$1,396	\$1,629	\$1,466	\$1,601	\$1,623	\$1,494	\$1,196	\$736
FCFF	-\$931	-\$1,024	-\$989	-\$758	-\$408	-\$163	\$177	\$625	\$1,174	\$1,788

Value of Op Assets	\$ 14,910
+ Cash	\$ 26
= Value of Firm	\$14,936
- Value of Debt	\$ 349
= Value of Equity	\$14,587
- Equity Options	\$ 2,892
Value per share	\$ 34.32

	1	2	3	4	5	6	7	8	9	10
Cost of Equity	12.90%	12.90%	12.90%	12.90%	12.90%	12.42%	12.30%	12.10%	11.70%	10.50%
Cost of Debt	8.00%	8.00%	8.00%	8.00%	8.00%	7.80%	7.75%	7.67%	7.50%	7.00%
AT cost of debt	8.00%	8.00%	8.00%	6.71%	5.20%	5.07%	5.04%	4.98%	4.88%	4.55%
Cost of Capital	12.84%	12.84%	12.84%	12.83%	12.81%	12.13%	11.96%	11.69%	11.15%	9.61%

Forever

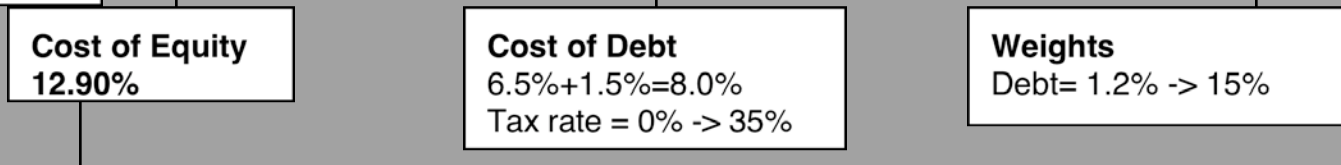

**Riskfree Rate :**  
T. Bond rate = 6.5%

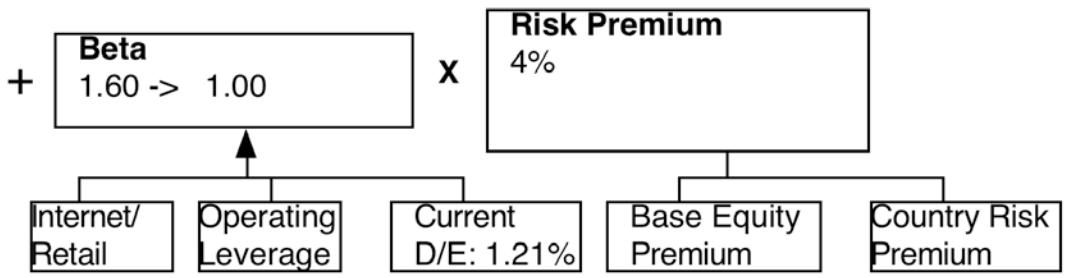

**Amazon.com**  
January 2000  
Stock Price = \$ 84

## Amazon.com: Break Even at \$84?

	6%	8%	10%	12%	14%
30%	\$ (1.94)	\$ 2.95	\$ 7.84	\$ 12.71	\$ 17.57
35%	\$ 1.41	\$ 8.37	\$ 15.33	\$ 22.27	\$ 29.21
40%	\$ 6.10	\$ 15.93	\$ 25.74	\$ 35.54	\$ 45.34
45%	\$ 12.59	\$ 26.34	\$ 40.05	\$ 53.77	\$ 67.48
50%	\$ 21.47	\$ 40.50	\$ 59.52	\$ 78.53	\$ 97.54
55%	\$ 33.47	\$ 59.60	\$ 85.72	\$ 111.84	\$ 137.95
60%	\$ 49.53	\$ 85.10	\$ 120.66	\$ 156.22	\$ 191.77

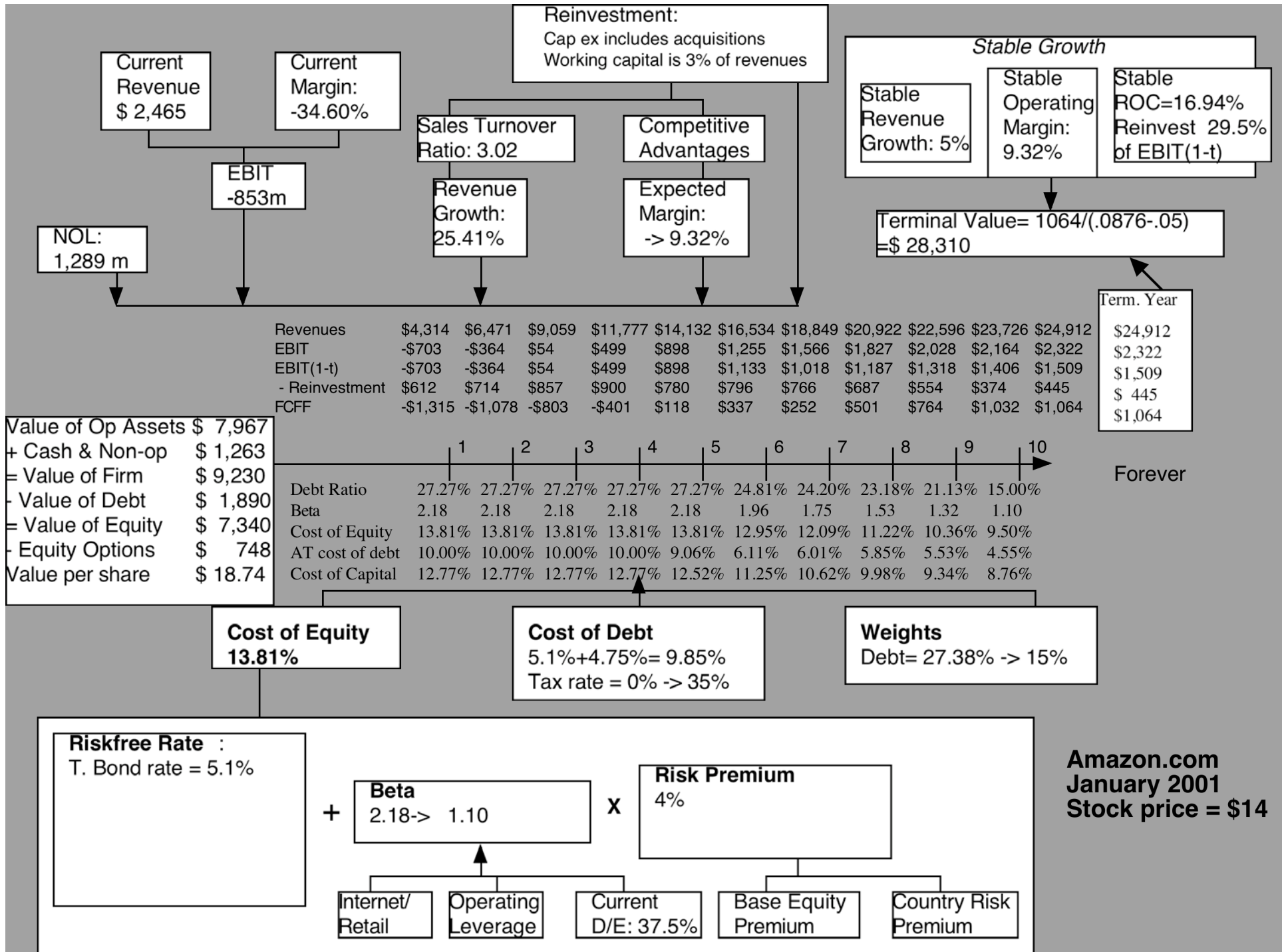

# Amazon over time...

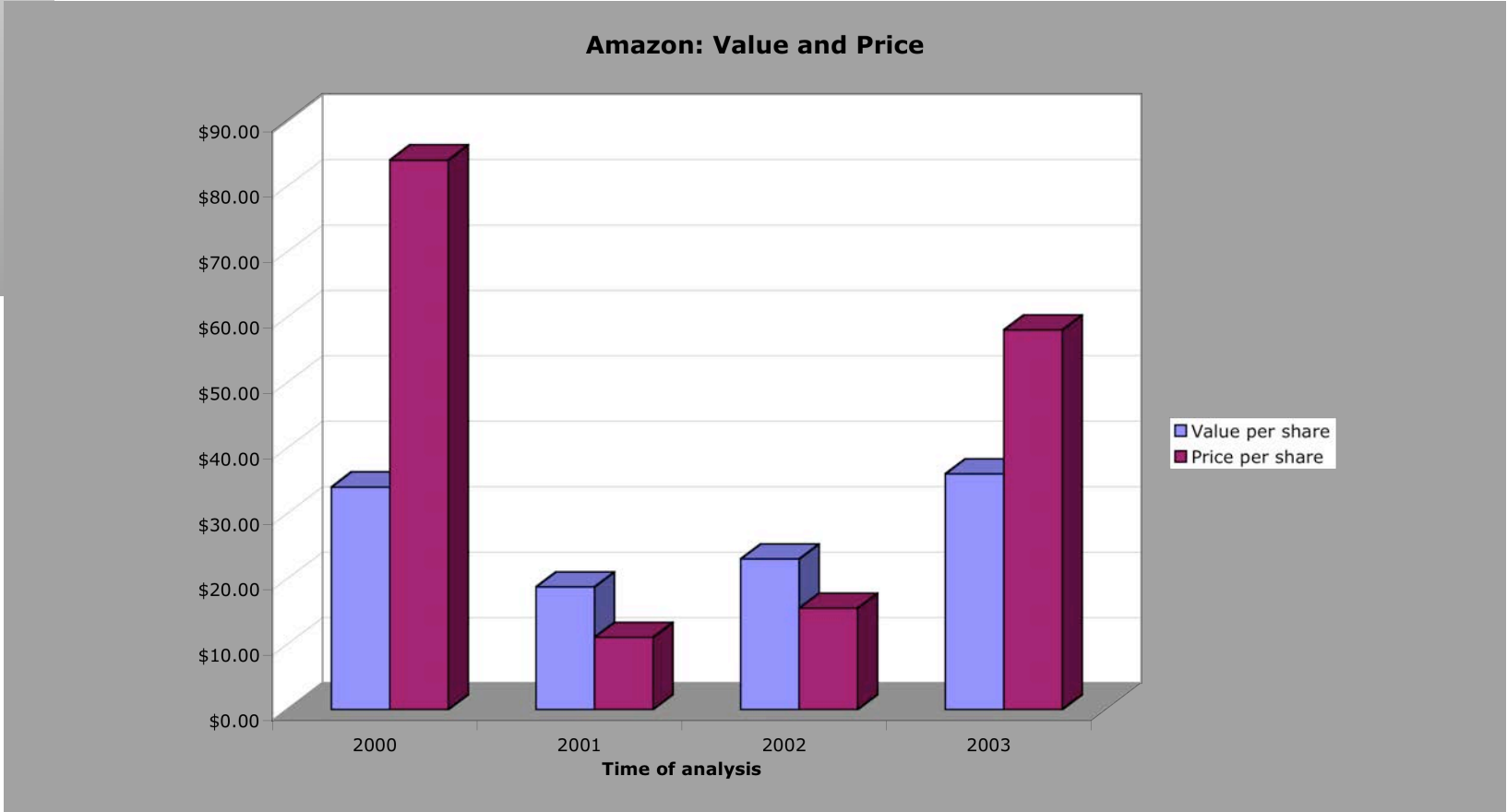



# Relative Valuation

Aswath Damodaran

## The Essence of relative valuation?

---

- In relative valuation, the value of an asset is compared to the values assessed by the market for similar or comparable assets.
- To do relative valuation then,
  - we need to identify comparable assets and obtain market values for these assets
  - convert these market values into standardized values, since the absolute prices cannot be compared This process of standardizing creates price multiples.
  - compare the standardized value or multiple for the asset being analyzed to the standardized values for comparable asset, controlling for any differences between the firms that might affect the multiple, to judge whether the asset is under or over valued



## Relative valuation is pervasive...

---

- Most asset valuations are relative.
- Most equity valuations on Wall Street are relative valuations.
  - Almost 85% of equity research reports are based upon a multiple and comparables.
  - More than 50% of all acquisition valuations are based upon multiples
  - Rules of thumb based on multiples are not only common but are often the basis for final valuation judgments.
- While there are more discounted cashflow valuations in consulting and corporate finance, they are often relative valuations masquerading as discounted cash flow valuations.
  - The objective in many discounted cashflow valuations is to back into a number that has been obtained by using a multiple.
  - The terminal value in a significant number of discounted cashflow valuations is estimated using a multiple.

## The Reasons for the allure...

---

“If you think I’m crazy, you should see the guy who lives across the hall”

*Jerry Seinfeld talking about Kramer in a Seinfeld episode*

“ A little inaccuracy sometimes saves tons of explanation”

H.H. Munro

“ If you are going to screw up, make sure that you have lots of company”

Ex-portfolio manager

## The Market Imperative....

---

- Relative valuation is much more likely to reflect market perceptions and moods than discounted cash flow valuation. This can be an advantage when it is important that the price reflect these perceptions as is the case when
  - the objective is to sell a security at that price today (as in the case of an IPO)
  - investing on “momentum” based strategies
- With relative valuation, there will always be a significant proportion of securities that are under valued and over valued.
- Since portfolio managers are judged based upon how they perform on a relative basis (to the market and other money managers), relative valuation is more tailored to their needs
- Relative valuation generally requires less information than discounted cash flow valuation (especially when multiples are used as screens)

# The Four Steps to Deconstructing Multiples

---

- Define the multiple
  - In use, the same multiple can be defined in different ways by different users. When comparing and using multiples, estimated by someone else, it is critical that we understand how the multiples have been estimated
- Describe the multiple
  - Too many people who use a multiple have no idea what its cross sectional distribution is. If you do not know what the cross sectional distribution of a multiple is, it is difficult to look at a number and pass judgment on whether it is too high or low.
- Analyze the multiple
  - It is critical that we understand the fundamentals that drive each multiple, and the nature of the relationship between the multiple and each variable.
- Apply the multiple
  - Defining the comparable universe and controlling for differences is far more difficult in practice than it is in theory.

## Definitional Tests

---

- Is the multiple consistently defined?
  - **Proposition 1: Both the value (the numerator) and the standardizing variable (the denominator) should be to the same claimholders in the firm. In other words, the value of equity should be divided by equity earnings or equity book value, and firm value should be divided by firm earnings or book value.**
- Is the multiple uniformly estimated?
  - The variables used in defining the multiple should be estimated uniformly across assets in the “comparable firm” list.
  - If earnings-based multiples are used, the accounting rules to measure earnings should be applied consistently across assets. The same rule applies with book-value based multiples.

## Example 1: Price Earnings Ratio: Definition

---

### **PE = Market Price per Share / Earnings per Share**

- There are a number of variants on the basic PE ratio in use. They are based upon how the price and the earnings are defined.
- Price:                    is usually the current price  
                                  is sometimes the average price for the year
- EPS:                     earnings per share in most recent financial year  
                                  earnings per share in trailing 12 months (Trailing PE)  
                                  forecasted earnings per share next year (Forward PE)  
                                  forecasted earnings per share in future year

## Example 2: Enterprise Value /EBITDA Multiple

- The enterprise value to EBITDA multiple is obtained by netting cash out against debt to arrive at enterprise value and dividing by EBITDA.

$$\frac{\text{Enterprise Value}}{\text{EBITDA}} = \frac{\text{Market Value of Equity} + \text{Market Value of Debt} - \text{Cash}}{\text{Earnings before Interest, Taxes and Depreciation}}$$

- Why do we net out cash from firm value?
- What happens if a firm has cross holdings which are categorized as:
  - Minority interests?
  - Majority active interests?

## Descriptive Tests

---

- What is the average and standard deviation for this multiple, across the universe (market)?
- What is the median for this multiple?
  - The median for this multiple is often a more reliable comparison point.
- How large are the outliers to the distribution, and how do we deal with the outliers?
  - Throwing out the outliers may seem like an obvious solution, but if the outliers all lie on one side of the distribution (they usually are large positive numbers), this can lead to a biased estimate.
- Are there cases where the multiple cannot be estimated? Will ignoring these cases lead to a biased estimate of the multiple?
- How has this multiple changed over time?



## Looking at the distribution...

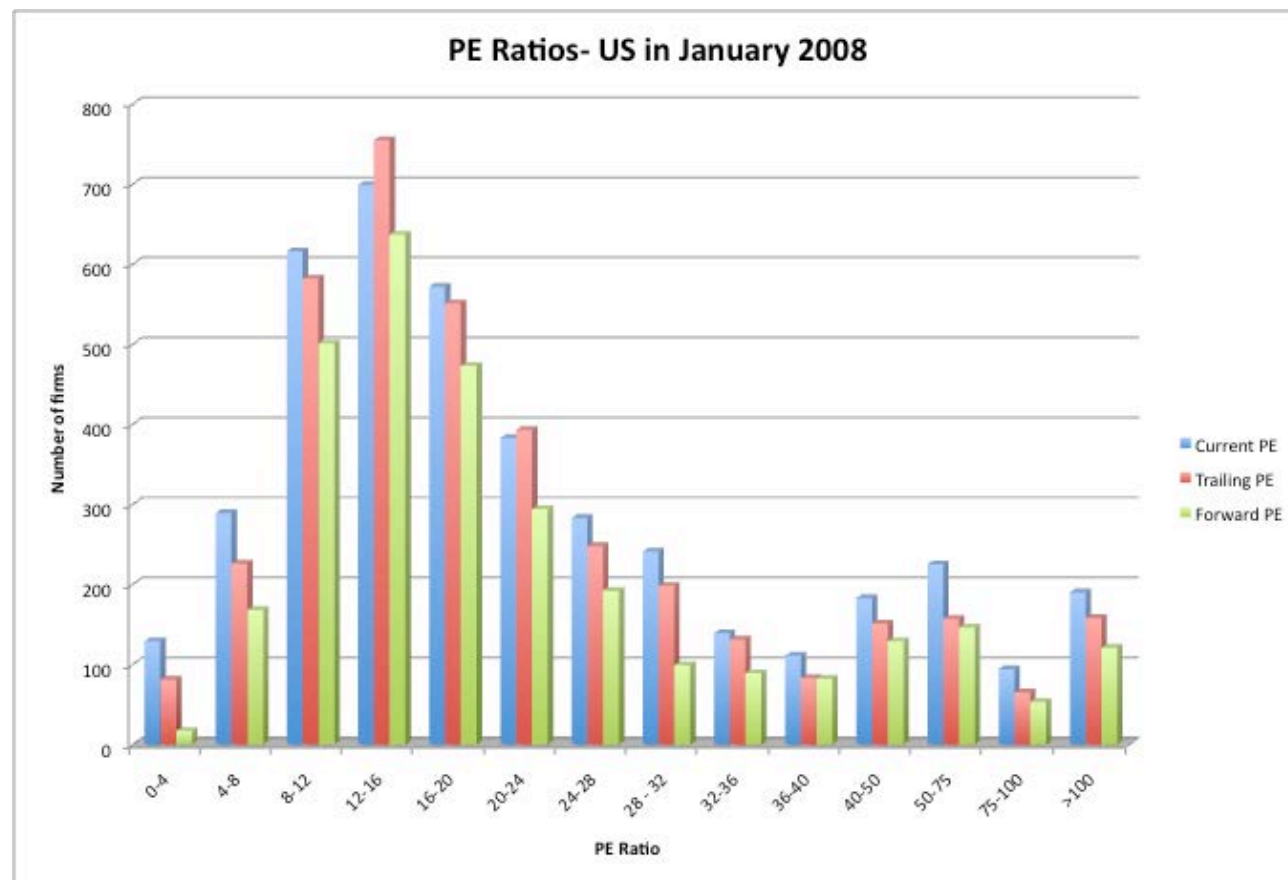

## PE: Deciphering the Distribution

---

	<i>Current PE</i>	<i>Trailing PE</i>	<i>Forward PE</i>
Mean	45.02	32.44	32.21
Standard Error	4.64	1.96	1.47
Median	18.16	17.00	17.28
Standard Deviation	299.11	123.29	80.82
Sample Variance	89468.12	15199.29	6532.53
Kurtosis	1618.20	1241.97	269.80
Skewness	35.41	30.30	14.23
Maximum	15126.20	5713.00	1912.33
Count	4155	3944	3004

# PE Ratios in China

## PE Ratios for China - September 2008

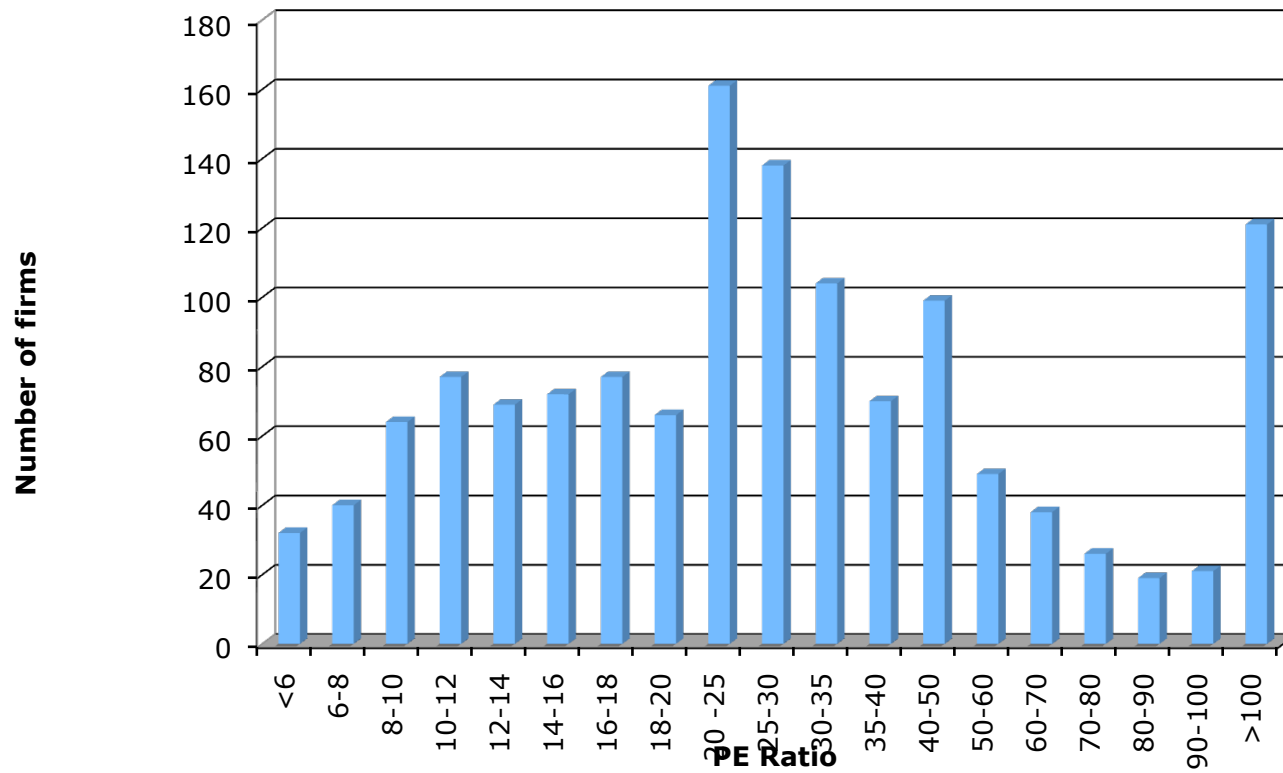

## And 8 times EBITDA is not cheap

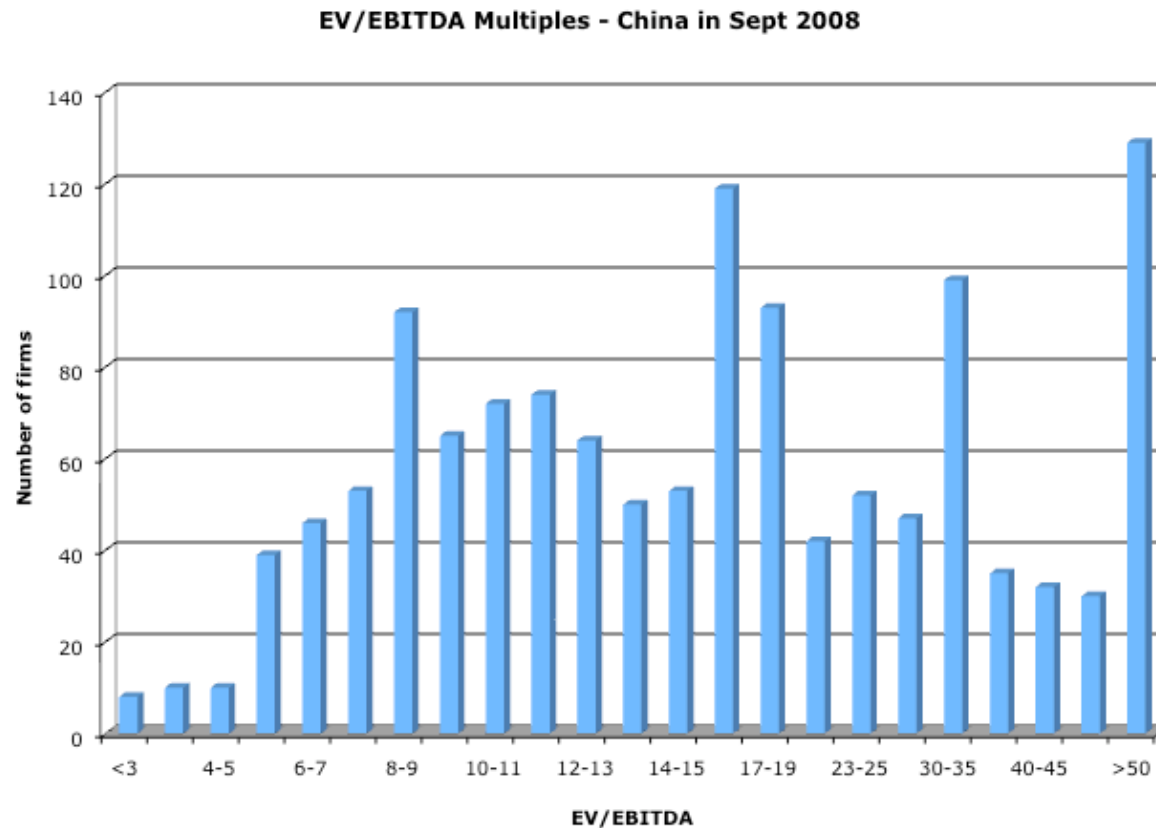

# Analytical Tests

---

- What are the fundamentals that determine and drive these multiples?
  - Proposition 2: Embedded in every multiple are all of the variables that drive every discounted cash flow valuation - growth, risk and cash flow patterns.
  - In fact, using a simple discounted cash flow model and basic algebra should yield the fundamentals that drive a multiple
- How do changes in these fundamentals change the multiple?
  - The relationship between a fundamental (like growth) and a multiple (such as PE) is seldom linear. For example, if firm A has twice the growth rate of firm B, it will generally not trade at twice its PE ratio
  - **Proposition 3: It is impossible to properly compare firms on a multiple, if we do not know the nature of the relationship between fundamentals and the multiple.**

## PE Ratio: Understanding the Fundamentals

- To understand the fundamentals, start with a basic equity discounted cash flow model.

- With the dividend discount model,

$$P_0 = \frac{DPS_1}{r - g_n}$$

- Dividing both sides by the current earnings per share,

$$\frac{P_0}{EPS_0} = PE = \frac{\text{Payout Ratio} * (1 + g_n)}{r - g_n}$$

- If this had been a FCFE Model,

$$P_0 = \frac{FCFE_1}{r - g_n}$$

$$\frac{P_0}{EPS_0} = PE = \frac{(\text{FCFE/Earnings}) * (1 + g_n)}{r - g_n}$$

## Using the Fundamental Model to Estimate PE For a High Growth Firm

- The price-earnings ratio for a high growth firm can also be related to fundamentals. In the special case of the two-stage dividend discount model, this relationship can be made explicit fairly simply:

$$P_0 = \frac{\text{EPS}_0 * \text{Payout Ratio} * (1+g) * \left(1 - \frac{(1+g)^n}{(1+r)^n}\right)}{r-g} + \frac{\text{EPS}_0 * \text{Payout Ratio}_n * (1+g)^n * (1+g_n)}{(r-g_n)(1+r)^n}$$

- For a firm that does not pay what it can afford to in dividends, substitute FCFE/ Earnings for the payout ratio.
- Dividing both sides by the earnings per share:

$$\frac{P_0}{\text{EPS}_0} = \frac{\text{Payout Ratio} * (1+g) * \left(1 - \frac{(1+g)^n}{(1+r)^n}\right)}{r-g} + \frac{\text{Payout Ratio}_n * (1+g)^n * (1+g_n)}{(r-g_n)(1+r)^n}$$

## A Simple Example

- Assume that you have been asked to estimate the PE ratio for a firm which has the following characteristics:

Variable	High Growth Phase	Stable Growth Phase
Expected Growth Rate	25%	8%
Payout Ratio	20%	50%
Beta	1.00	1.00
Number of years	5 years	Forever after year 5

- Riskfree rate = T.Bond Rate = 6%
- Required rate of return = 6% + 1(5.5%)= 11.5%

$$PE = \frac{0.2 * (1.25) * \left(1 - \frac{(1.25)^5}{(1.115)^5}\right)}{(.115 - .25)} + \frac{0.5 * (1.25)^5 * (1.08)}{(.115 - .08) (1.115)^5} = 28.75$$



a. PE and Growth: Firm grows at  $x\%$  for 5 years, 8% thereafter

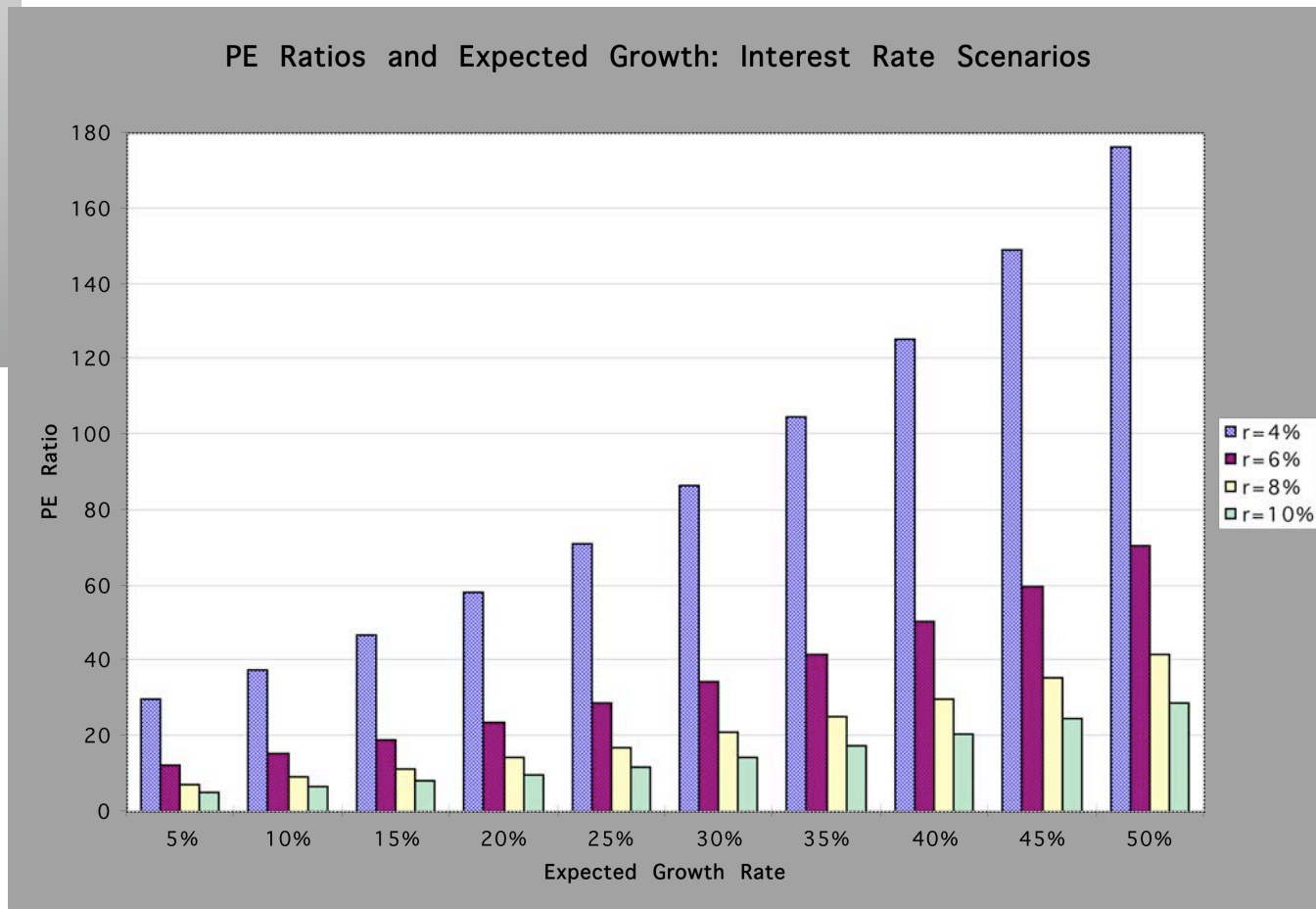

## b. PE and Risk: A Follow up Example

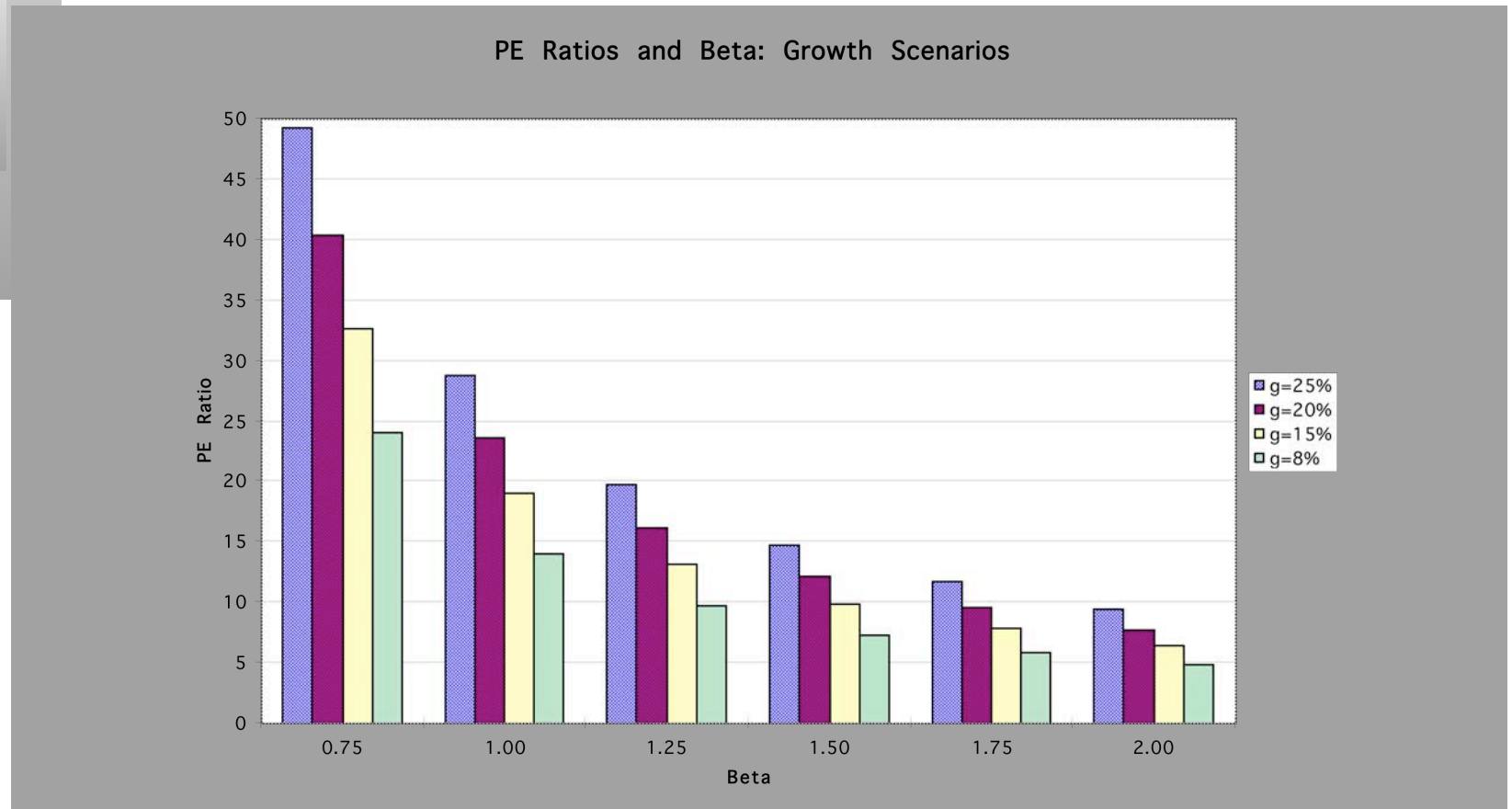

## Comparisons of PE across time: PE Ratio for the S&P 500

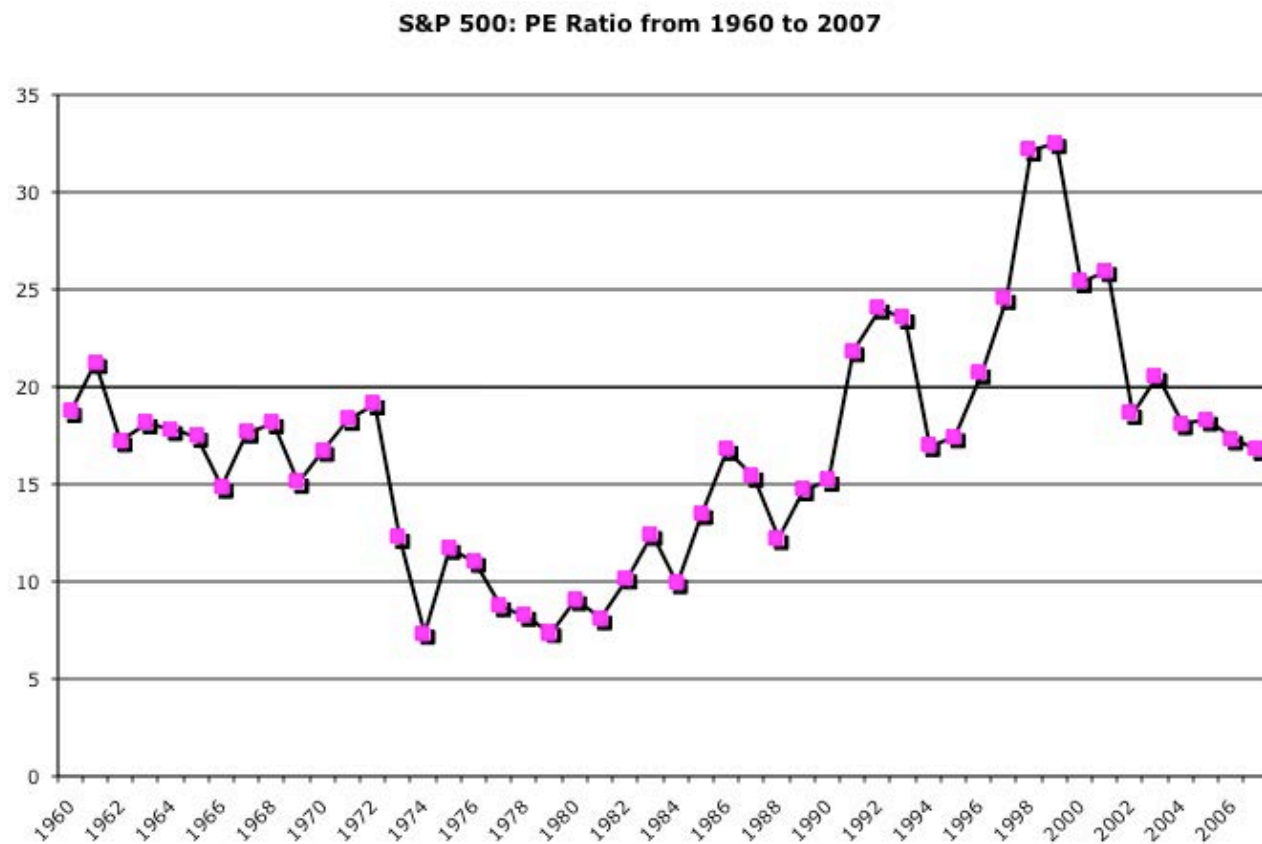

## Is low (high) PE cheap (expensive)?

---

- A market strategist argues that stocks are over priced because the PE ratio today is too high relative to the average PE ratio across time. Do you agree?
  - Yes
  - No
- If you do not agree, what factors might explain the higher PE ratio today?

# E/P Ratios , T.Bond Rates and Term Structure

US Market: E/P and Interest Rates: 1960-2007

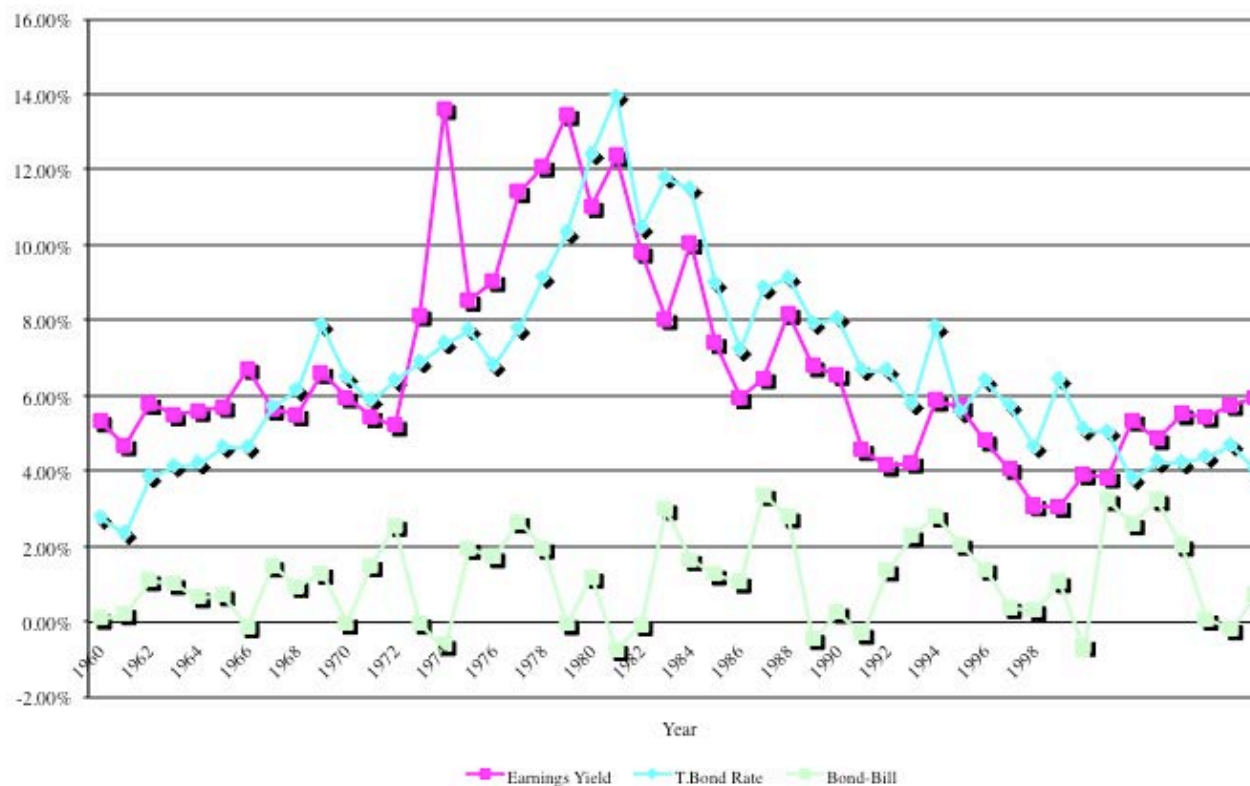

## Regression Results

---

- There is a strong positive relationship between E/P ratios and T.Bond rates, as evidenced by the correlation of 0.70 between the two variables.,
- In addition, there is evidence that the term structure also affects the PE ratio.
- In the following regression, using 1960-2007 data, we regress E/P ratios against the level of T.Bond rates and a term structure variable (T.Bond - T.Bill rate)

$$E/P = 2.19\% + 0.734 \text{ T.Bond Rate} - 0.335 (\text{T.Bond Rate} - \text{T.Bill Rate})$$

(2.70)                      (6.80)                      (-1.41)

$$R \text{ squared} = 51.23\%$$

# The Determinants of Multiples...

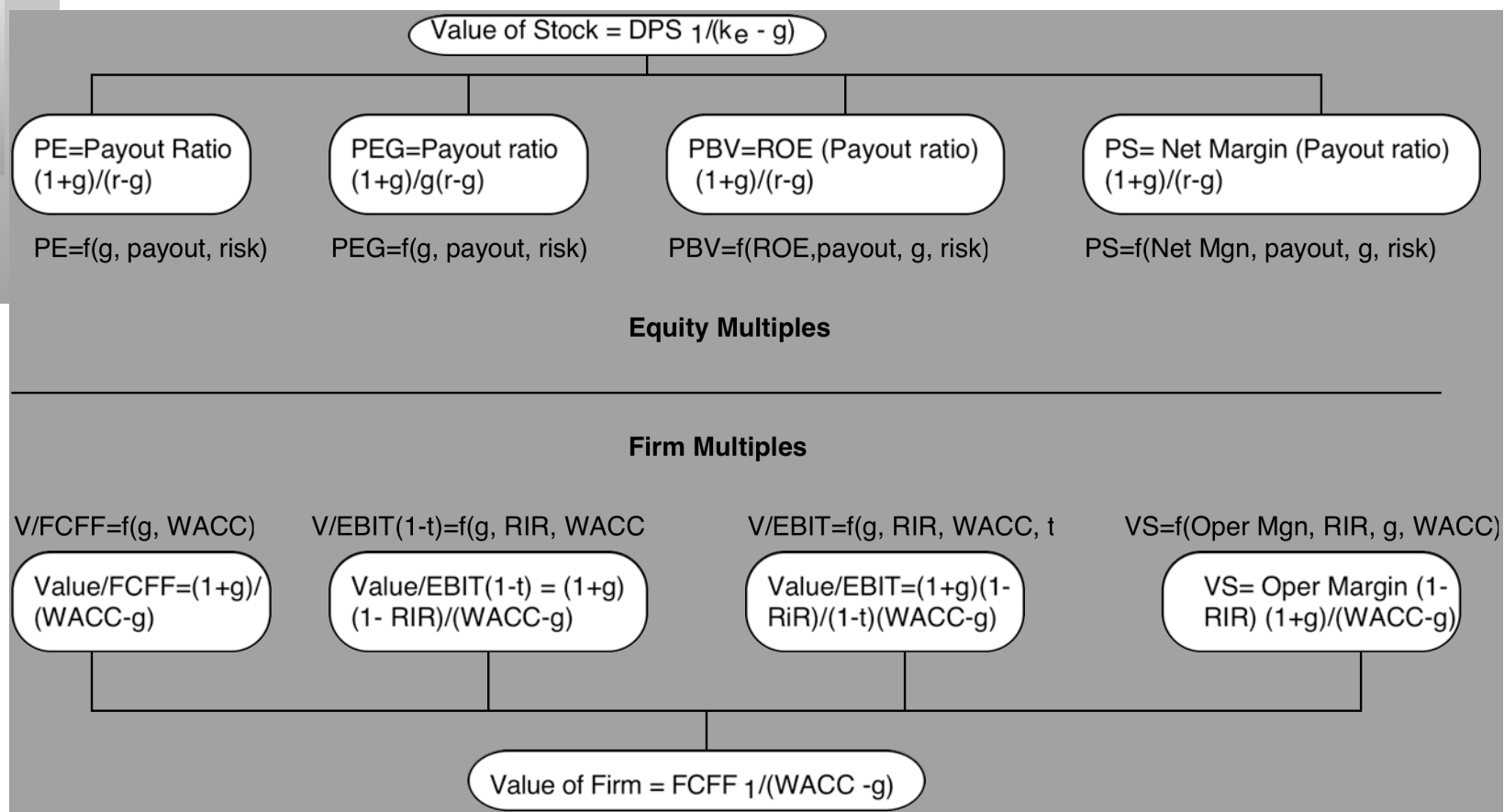

## Application Tests

---

- Given the firm that we are valuing, what is a “comparable” firm?
  - While traditional analysis is built on the premise that firms in the same sector are comparable firms, valuation theory would suggest that a comparable firm is one which is similar to the one being analyzed in terms of fundamentals.
  - **Proposition 4: There is no reason why a firm cannot be compared with another firm in a very different business, if the two firms have the same risk, growth and cash flow characteristics.**
- Given the comparable firms, how do we adjust for differences across firms on the fundamentals?
  - **Proposition 5: It is impossible to find an exactly identical firm to the one you are valuing.**



## I. Comparing PE Ratios across a Sector: PE

<i>Company Name</i>	<i>PE</i>	<i>Growth</i>
<i>PT Indosat ADR</i>	<i>7.8</i>	<i>0.06</i>
<i>Telebras ADR</i>	<i>8.9</i>	<i>0.075</i>
<i>Telecom Corporation of New Zealand ADR</i>	<i>11.2</i>	<i>0.11</i>
<i>Telecom Argentina Stet - France Telecom SA ADR B</i>	<i>12.5</i>	<i>0.08</i>
<i>Hellenic Telecommunication Organization SA ADR</i>	<i>12.8</i>	<i>0.12</i>
<i>Telecomunicaciones de Chile ADR</i>	<i>16.6</i>	<i>0.08</i>
<i>Swisscom AG ADR</i>	<i>18.3</i>	<i>0.11</i>
<i>Asia Satellite Telecom Holdings ADR</i>	<i>19.6</i>	<i>0.16</i>
<i>Portugal Telecom SA ADR</i>	<i>20.8</i>	<i>0.13</i>
<i>Telefonos de Mexico ADR L</i>	<i>21.1</i>	<i>0.14</i>
<i>Matav RT ADR</i>	<i>21.5</i>	<i>0.22</i>
<i>Telstra ADR</i>	<i>21.7</i>	<i>0.12</i>
<i>Gilat Communications</i>	<i>22.7</i>	<i>0.31</i>
<i>Deutsche Telekom AG ADR</i>	<i>24.6</i>	<i>0.11</i>
<i>British Telecommunications PLC ADR</i>	<i>25.7</i>	<i>0.07</i>
<i>Tele Danmark AS ADR</i>	<i>27</i>	<i>0.09</i>
<i>Telekomunikasi Indonesia ADR</i>	<i>28.4</i>	<i>0.32</i>
<i>Cable &amp; Wireless PLC ADR</i>	<i>29.8</i>	<i>0.14</i>
<i>APT Satellite Holdings ADR</i>	<i>31</i>	<i>0.33</i>
<i>Telefonica SA ADR</i>	<i>32.5</i>	<i>0.18</i>
<i>Royal KPN NV ADR</i>	<i>35.7</i>	<i>0.13</i>
<i>Telecom Italia SPA ADR</i>	<i>42.2</i>	<i>0.14</i>
<i>Nippon Telegraph &amp; Telephone ADR</i>	<i>44.3</i>	<i>0.2</i>
<i>France Telecom SA ADR</i>	<i>45.2</i>	<i>0.19</i>
<i>Korea Telecom ADR</i>	<i>71.3</i>	<i>0.44</i>

## PE, Growth and Risk

---

Dependent variable is: PE

R squared = 66.2%    R squared (adjusted) = 63.1%

Variable	Coefficient	SE	t-ratio	prob
Constant	13.1151	3.471	3.78	0.0010
Growth rate	121.223	19.27	6.29	≤ 0.0001
Emerging Market	-13.8531	3.606	-3.84	0.0009

Emerging Market is a dummy: 1 if emerging market  
0 if not

## Is Telebras under valued?

---

- Predicted PE =  $13.12 + 121.22 (.075) - 13.85 (1) = 8.35$
- At an actual price to earnings ratio of 8.9, Telebras is slightly overvalued.

## II. Price to Book vs ROE: Chinese Stocks in September 2008

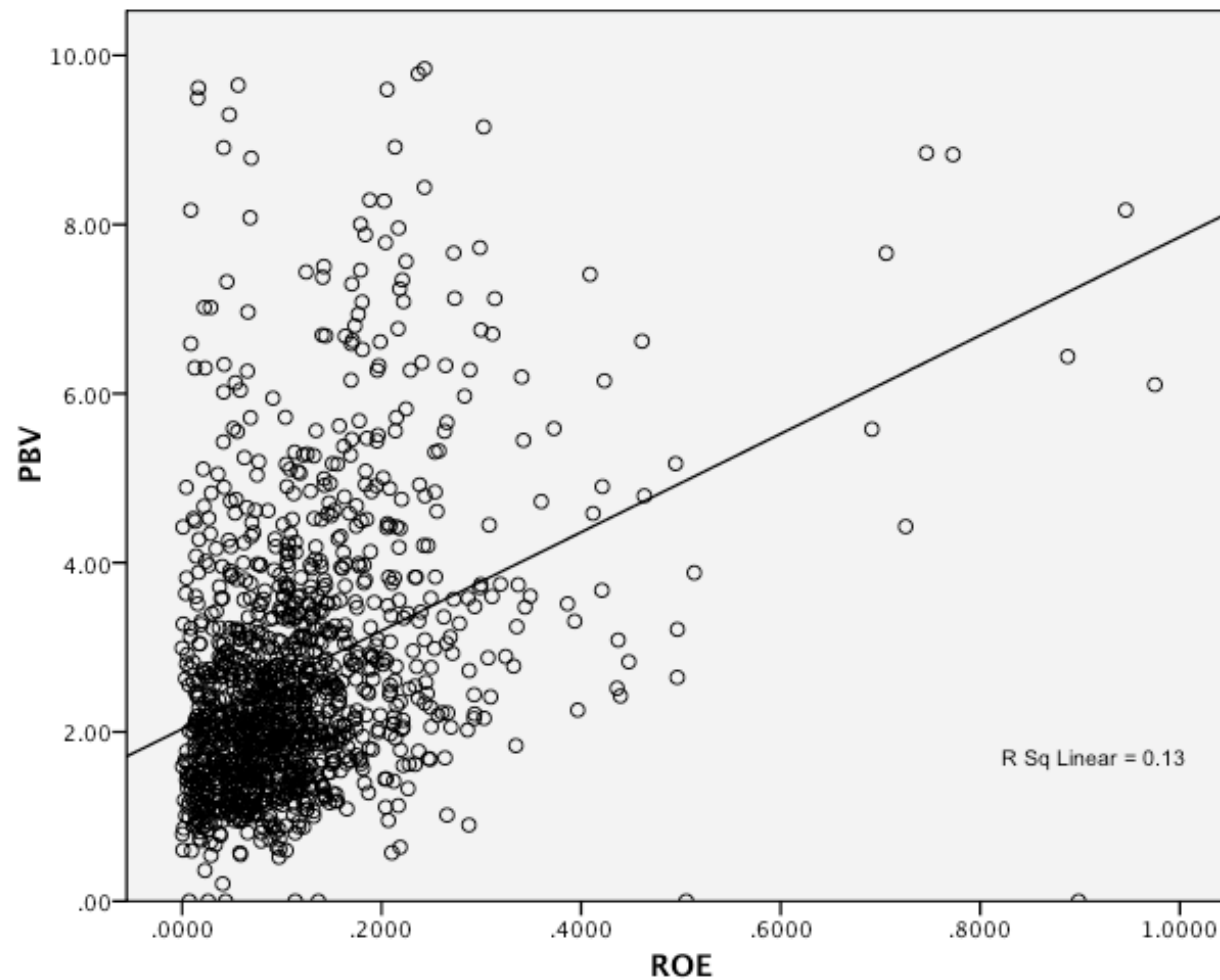

## A Risk Adjusted Version?

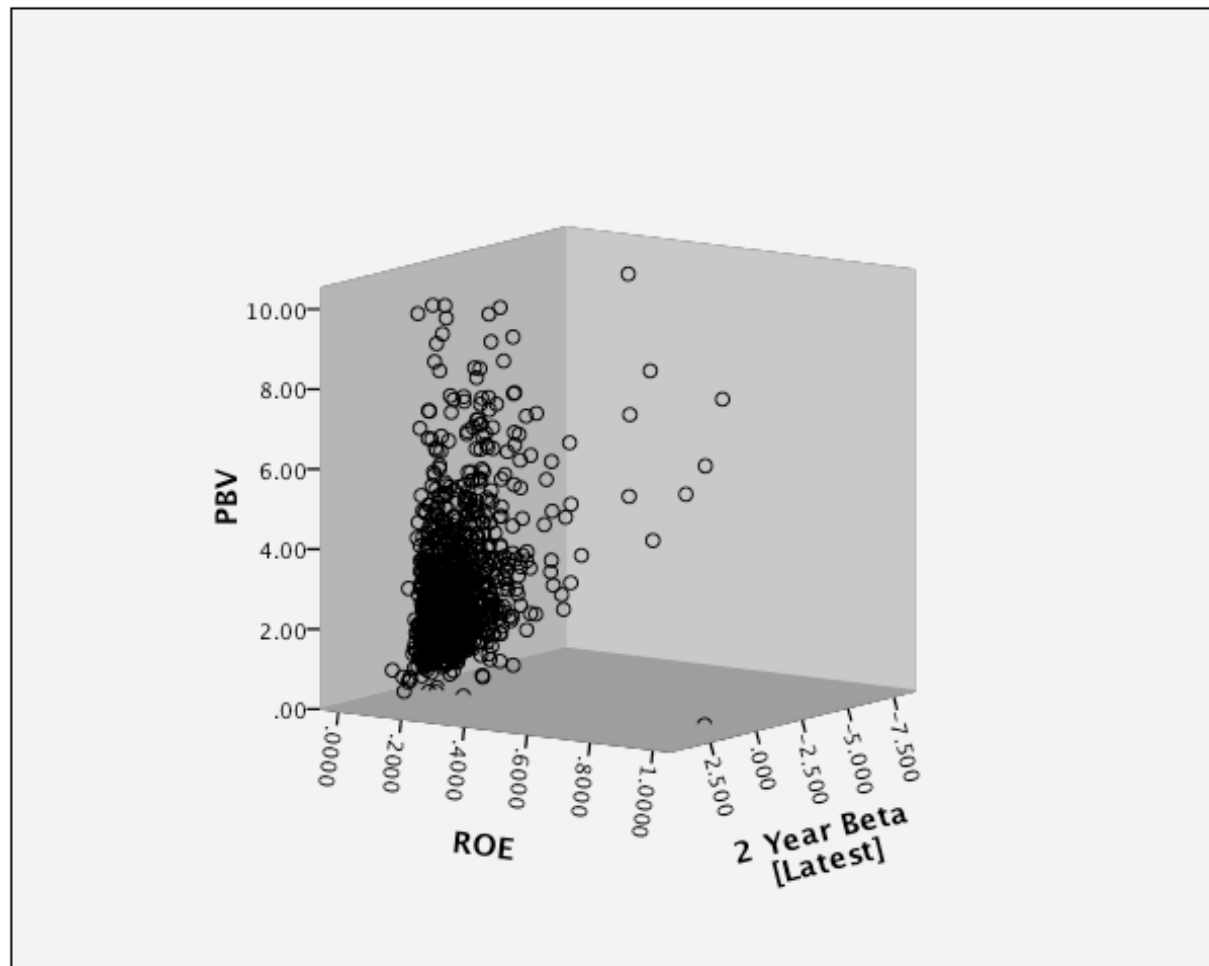

### III. Value/EBITDA Multiple: Trucking Companies

Company Name	Value	EBITDA	Value/EBITDA
KLLM Trans. Svcs.	\$ 114.32	\$ 48.81	2.34
Ryder System	\$ 5,158.04	\$ 1,838.26	2.81
Rollins Truck Leasing	\$ 1,368.35	\$ 447.67	3.06
Cannon Express Inc.	\$ 83.57	\$ 27.05	3.09
Hunt (J.B.)	\$ 982.67	\$ 310.22	3.17
Yellow Corp.	\$ 931.47	\$ 292.82	3.18
Roadway Express	\$ 554.96	\$ 169.38	3.28
Marten Transport Ltd.	\$ 116.93	\$ 35.62	3.28
Kenan Transport Co.	\$ 67.66	\$ 19.44	3.48
M.S. Carriers	\$ 344.93	\$ 97.85	3.53
Old Dominion Freight	\$ 170.42	\$ 45.13	3.78
Trimac Ltd	\$ 661.18	\$ 174.28	3.79
Matlack Systems	\$ 112.42	\$ 28.94	3.88
XTRA Corp.	\$ 1,708.57	\$ 427.30	4.00
Covenant Transport Inc	\$ 259.16	\$ 64.35	4.03
Builders Transport	\$ 221.09	\$ 51.44	4.30
Werner Enterprises	\$ 844.39	\$ 196.15	4.30
Landstar Sys.	\$ 422.79	\$ 95.20	4.44
AMERCO	\$ 1,632.30	\$ 345.78	4.72
USA Truck	\$ 141.77	\$ 29.93	4.74
Frozen Food Express	\$ 164.17	\$ 34.10	4.81
Arnold Inds.	\$ 472.27	\$ 96.88	4.87
Greyhound Lines Inc.	\$ 437.71	\$ 89.61	4.88
USFreightways	\$ 983.86	\$ 198.91	4.95
Golden Eagle Group Inc.	\$ 12.50	\$ 2.33	5.37
Arkansas Best	\$ 578.78	\$ 107.15	5.40
Airlease Ltd.	\$ 73.64	\$ 13.48	5.46
Celadon Group	\$ 182.30	\$ 32.72	5.57
Amer. Freightways	\$ 716.15	\$ 120.94	5.92
Transfinancial Holdings	\$ 56.92	\$ 8.79	6.47
Vitrans Corp. 'A'	\$ 140.68	\$ 21.51	6.54
Interpool Inc.	\$ 1,002.20	\$ 151.18	6.63
Intrenet Inc.	\$ 70.23	\$ 10.38	6.77
Swift Transportation	\$ 835.58	\$ 121.34	6.89
Landair Services	\$ 212.95	\$ 30.38	7.01
CNF Transportation	\$ 2,700.69	\$ 366.99	7.36
Budget Group Inc	\$ 1,247.30	\$ 166.71	7.48
Caliber System	\$ 2,514.99	\$ 333.13	7.55
Knight Transportation Inc	\$ 269.01	\$ 28.20	9.54
Heartland Express	\$ 727.50	\$ 64.62	11.26
Greyhound CDA Transn Corp	\$ 83.25	\$ 6.99	11.91
Mark VII	\$ 160.45	\$ 12.96	12.38
Coach USA Inc	\$ 678.38	\$ 51.76	13.11
US 1 Inds Inc.	\$ 5.60	\$ (0.17)	NA
<b>Average</b>			<b>5.61</b>

## A Test on EBITDA

---

- Ryder System looks very cheap on a Value/EBITDA multiple basis, relative to the rest of the sector. What explanation (other than misvaluation) might there be for this difference?

## IV. A Case Study: Internet Stocks in early 2000

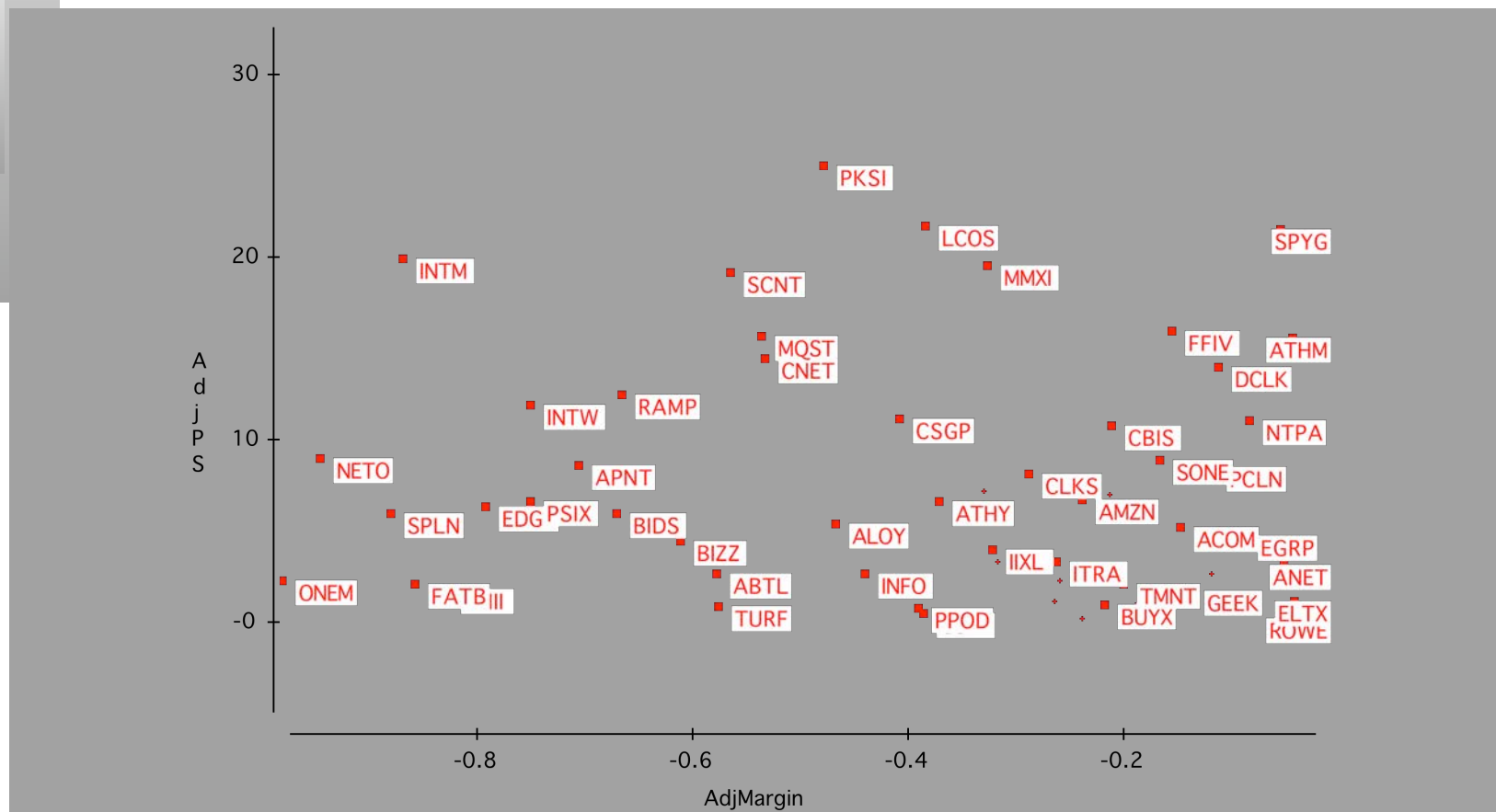



## PS Ratios and Margins are not highly correlated

---

- Regressing PS ratios against current margins yields the following  
$$PS = 81.36 - 7.54(\text{Net Margin}) \quad R^2 = 0.04$$

(0.49)
- This is not surprising. These firms are priced based upon expected margins, rather than current margins.

## Solution 1: Use proxies for survival and growth: Amazon in early 2000

---

- Hypothesizing that firms with higher revenue growth and higher cash balances should have a greater chance of surviving and becoming profitable, we ran the following regression: (The level of revenues was used to control for size)

$$\text{PS} = 30.61 - 2.77 \ln(\text{Rev}) + 6.42 (\text{Rev Growth}) + 5.11 (\text{Cash/Rev})$$

(0.66)                      (2.63)      (3.49)

R squared = 31.8%

Predicted PS =  $30.61 - 2.77(7.1039) + 6.42(1.9946) + 5.11 (.3069) = 30.42$

Actual PS = 25.63

Stock is undervalued, relative to other internet stocks.

## Solution 2: Use forward multiples

---

- Global Crossing lost \$1.9 billion in 2001 and is expected to continue to lose money for the next 3 years. In a discounted cashflow valuation (see notes on DCF valuation) of Global Crossing, we estimated an expected EBITDA for Global Crossing in five years of \$ 1,371 million.
- The average enterprise value/ EBITDA multiple for healthy telecomm firms is 7.2 currently.
- Applying this multiple to Global Crossing's EBITDA in year 5, yields a value in year 5 of
  - Enterprise Value in year 5 =  $1371 * 7.2 = \$9,871$  million
  - Enterprise Value today =  $\$ 9,871 \text{ million} / 1.138^5 = \$5,172$  million  
(The cost of capital for Global Crossing is 13.80%)
  - The probability that Global Crossing will not make it as a going concern is 77%.
  - Expected Enterprise value today =  $0.23 (5172) = \$1,190$  million

## Comparisons to the entire market: Why not?

---

- In contrast to the 'comparable firm' approach, the information in the entire cross-section of firms can be used to predict PE ratios.
- The simplest way of summarizing this information is with a multiple regression, with the PE ratio as the dependent variable, and proxies for risk, growth and payout forming the independent variables.

## PE versus Expected EPS Growth: January 2008

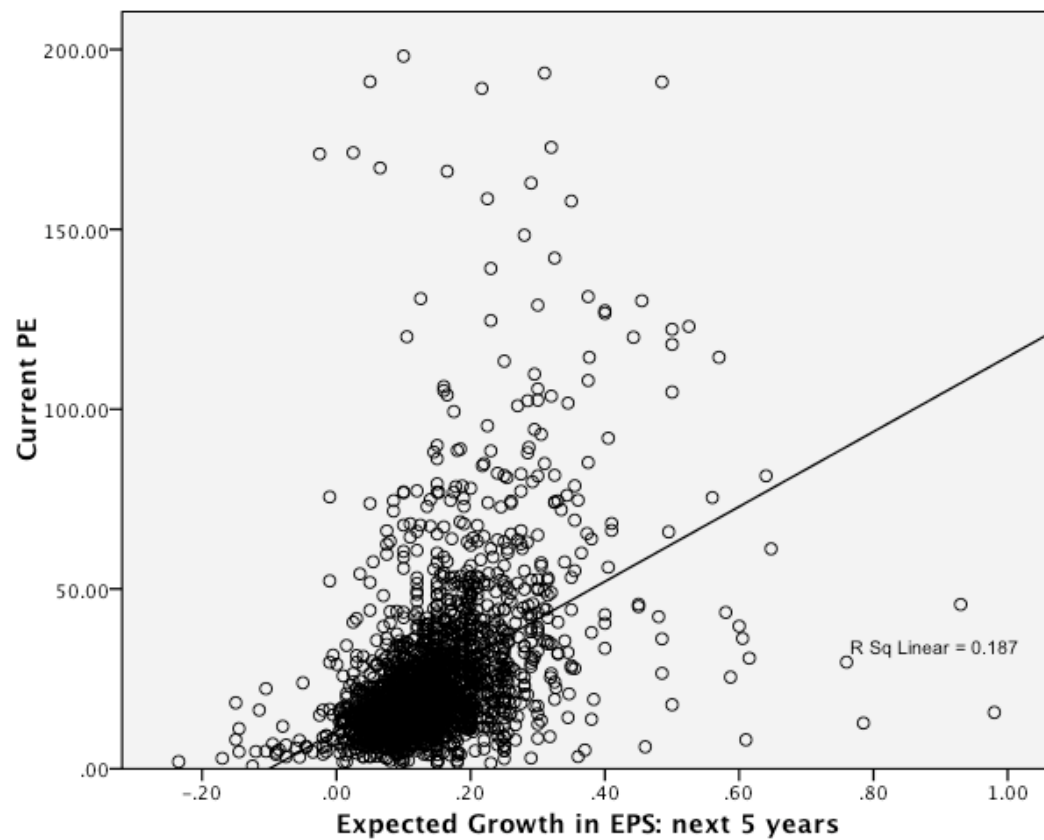

## PE Ratio: Standard Regression for US stocks - January 2008

**Model Summary**

Model	R	R Square	Adjusted R Square	Std. Error of the Estimate
1	.647 <sup>a</sup>	.419	.418	1273.85784

a. Predictors: (Constant), 3-yr Regression Beta, Expected Growth in EPS: next 5 years, Payout Ratio

**Coefficients<sup>ab</sup>**

Model		Unstandardized Coefficients		Standardized Coefficients	t	Sig.
		B	Std. Error	Beta		
1	(Constant)	2.741	.914		2.999	.003
	Expected Growth in EPS: next 5 years	142.627	4.029	.669	35.397	.000
	Payout Ratio	5.668	1.199	.090	4.726	.000
	3-yr Regression Beta	.550	.477	.021	1.153	.249

a. Dependent Variable: Current PE

b. Weighted Least Squares Regression - Weighted by Market Cap

## Fundamentals hold in every market: PE regressions across markets...

Region	Regression	R squared
Europe	PE = 14.15 – 2.62 Beta + 7.50 Payout + 29.06 Expected growth rate	17.9%
Japan	PE = 13.55 – 1.25 Beta + 26.05 Payout + 11.87 Expected growth rate	18.4%
Emerging Markets	PE = 5.63 + 11.35 Beta + 2.71 Payout + 92.72 Expected growth rate	13.9%

## Relative Valuation: Some closing propositions

---

- Proposition 1: In a relative valuation, all that you are concluding is that a stock is under or over valued, relative to your comparable group.
  - Your relative valuation judgment can be right and your stock can be hopelessly over valued at the same time.
- Proposition 2: In asset valuation, there are no similar assets. Every asset is unique.
  - If you don't control for fundamental differences in risk, cashflows and growth across firms when comparing how they are priced, your valuation conclusions will reflect your flawed judgments rather than market misvaluations.



## Choosing Between the Multiples

---

- As presented in this section, there are dozens of multiples that can be potentially used to value an individual firm.
- In addition, relative valuation can be relative to a sector (or comparable firms) or to the entire market (using the regressions, for instance)
- Since there can be only one final estimate of value, there are three choices at this stage:
  - Use a simple average of the valuations obtained using a number of different multiples
  - Use a weighted average of the valuations obtained using a number of different multiples
  - Choose one of the multiples and base your valuation on that multiple

## Picking one Multiple

---

- This is usually the best way to approach this issue. While a range of values can be obtained from a number of multiples, the “best estimate” value is obtained using one multiple.
- The multiple that is used can be chosen in one of two ways:
  - Use the multiple that best fits your objective. Thus, if you want the company to be undervalued, you pick the multiple that yields the highest value.
  - Use the multiple that has the highest R-squared in the sector when regressed against fundamentals. Thus, if you have tried PE, PBV, PS, etc. and run regressions of these multiples against fundamentals, use the multiple that works best at explaining differences across firms in that sector.
  - Use the multiple that seems to make the most sense for that sector, given how value is measured and created.

## A More Intuitive Approach

---

- Managers in every sector tend to focus on specific variables when analyzing strategy and performance. The multiple used will generally reflect this focus. Consider three examples.
  - In retailing: The focus is usually on same store sales (turnover) and profit margins. Not surprisingly, the revenue multiple is most common in this sector.
  - In financial services: The emphasis is usually on return on equity. Book Equity is often viewed as a scarce resource, since capital ratios are based upon it. Price to book ratios dominate.
  - In technology: Growth is usually the dominant theme. PEG ratios were invented in this sector.

## In Practice...

- As a general rule of thumb, the following table provides a way of picking a multiple for a sector

<i>Sector</i>	<i>Multiple Used</i>	<i>Rationale</i>
Cyclical Manufacturing	PE, Relative PE	Often with normalized earnings
High Tech, High Growth	PEG	Big differences in growth across firms
High Growth/No Earnings	PS, VS	Assume future margins will be good
Heavy Infrastructure	EV/EBITDA	Losses/ Big depreciation charges
Financial Services	PBV	Book value often marked to market
Retailing	PS VS	If leverage is similar across firms If leverage is different

## Reviewing: The Four Steps to Understanding Multiples

---

- Define the multiple
  - Check for consistency
  - Make sure that they are estimated uniformly
- Describe the multiple
  - Multiples have skewed distributions: The averages are seldom good indicators of typical multiples
  - Check for bias, if the multiple cannot be estimated
- Analyze the multiple
  - Identify the companion variable that drives the multiple
  - Examine the nature of the relationship
- Apply the multiple



# Real Options: Fact and Fantasy

Aswath Damodaran

## Underlying Theme: Searching for an Elusive Premium

---

- Traditional discounted cashflow models under estimate the value of investments, where there are options embedded in the investments to
  - Delay or defer making the investment (delay)
  - Adjust or alter production schedules as price changes (flexibility)
  - Expand into new markets or products at later stages in the process, based upon observing favorable outcomes at the early stages (expansion)
  - Stop production or abandon investments if the outcomes are unfavorable at early stages (abandonment)
- Put another way, real option advocates believe that you should be paying a premium on discounted cashflow value estimates.

## A Real Option Premium

- In the last few years, there are some who have argued that discounted cashflow valuations under valued some companies and that a real option premium should be tacked on to DCF valuations. To understanding its moorings, compare the two trees below:

A bad investment..... Becomes a good one..

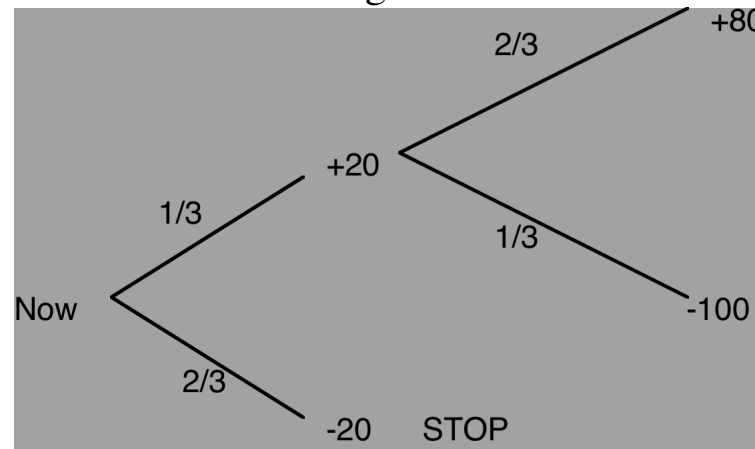
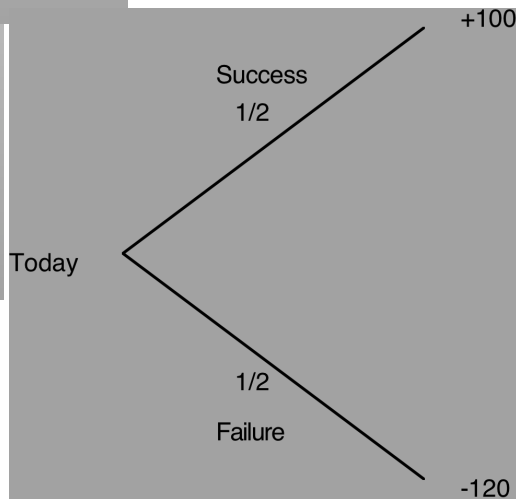

1. Learn at relatively low cost
2. Make better decisions based on learning



## Three Basic Questions

---

- When is there a real option embedded in a decision or an asset?
- When does that real option have significant economic value?
- Can that value be estimated using an option pricing model?

## When is there an option embedded in an action?

---

- An option provides the holder with the **right** to buy or sell a specified quantity of an underlying asset at a fixed price (called a strike price or an exercise price) at or before the expiration date of the option.
- There has to be a clearly defined underlying asset whose value changes over time in unpredictable ways.
- The payoffs on this asset (real option) have to be contingent on an specified event occurring within a finite period.

# Payoff Diagram on a Call

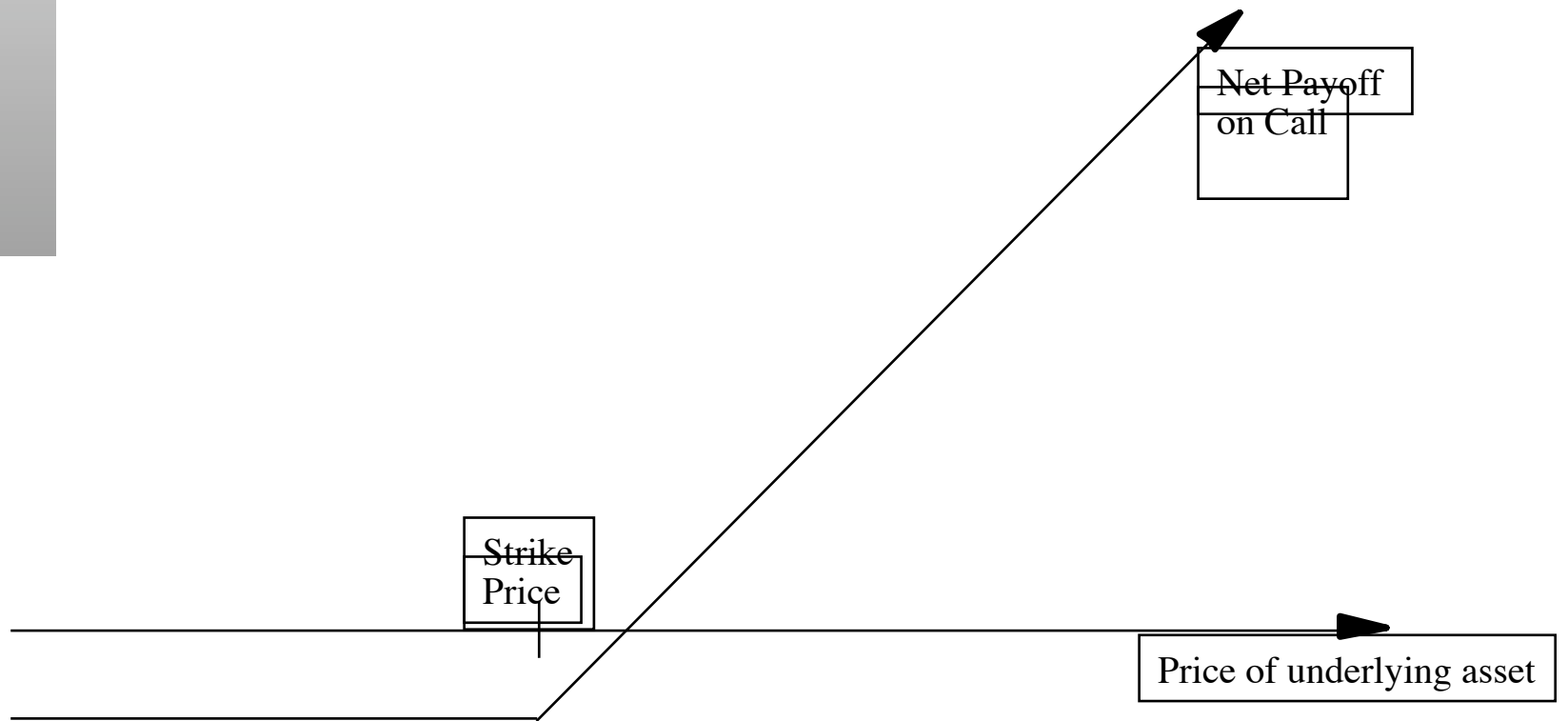

## Example 1: Product Patent as an Option

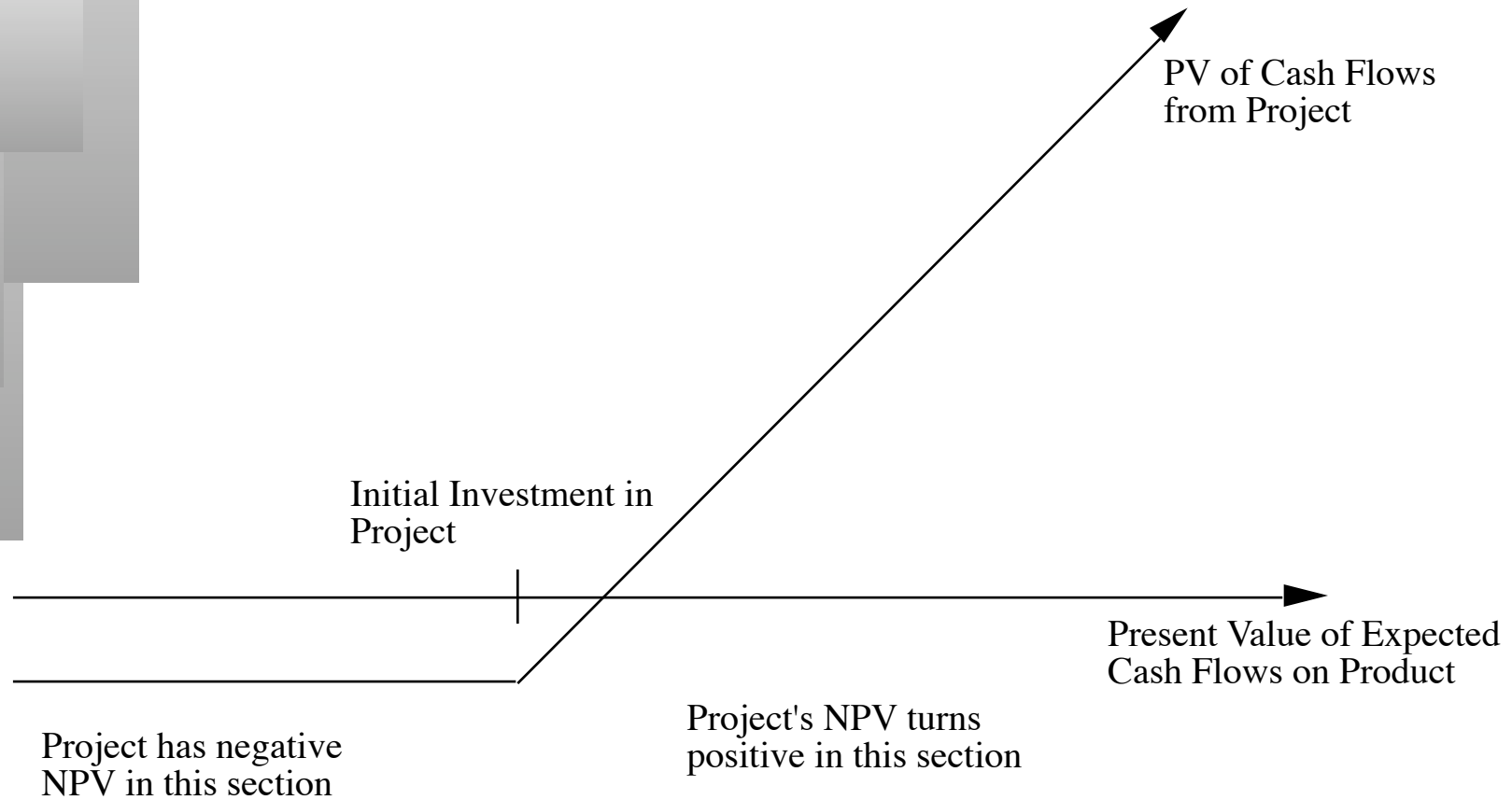

## Example 2: Undeveloped Oil Reserve as an option

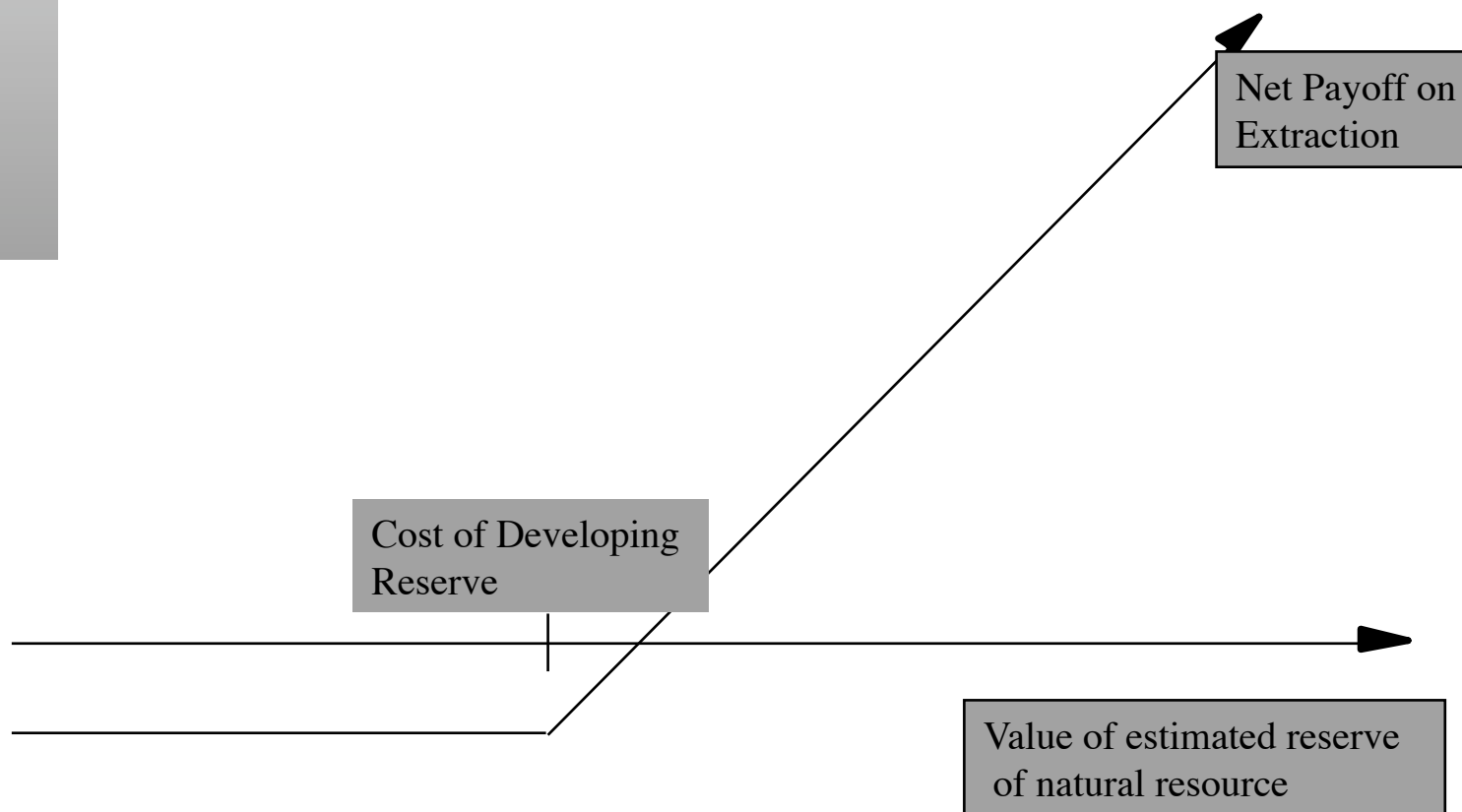

## Example 3: Expansion of existing project as an option

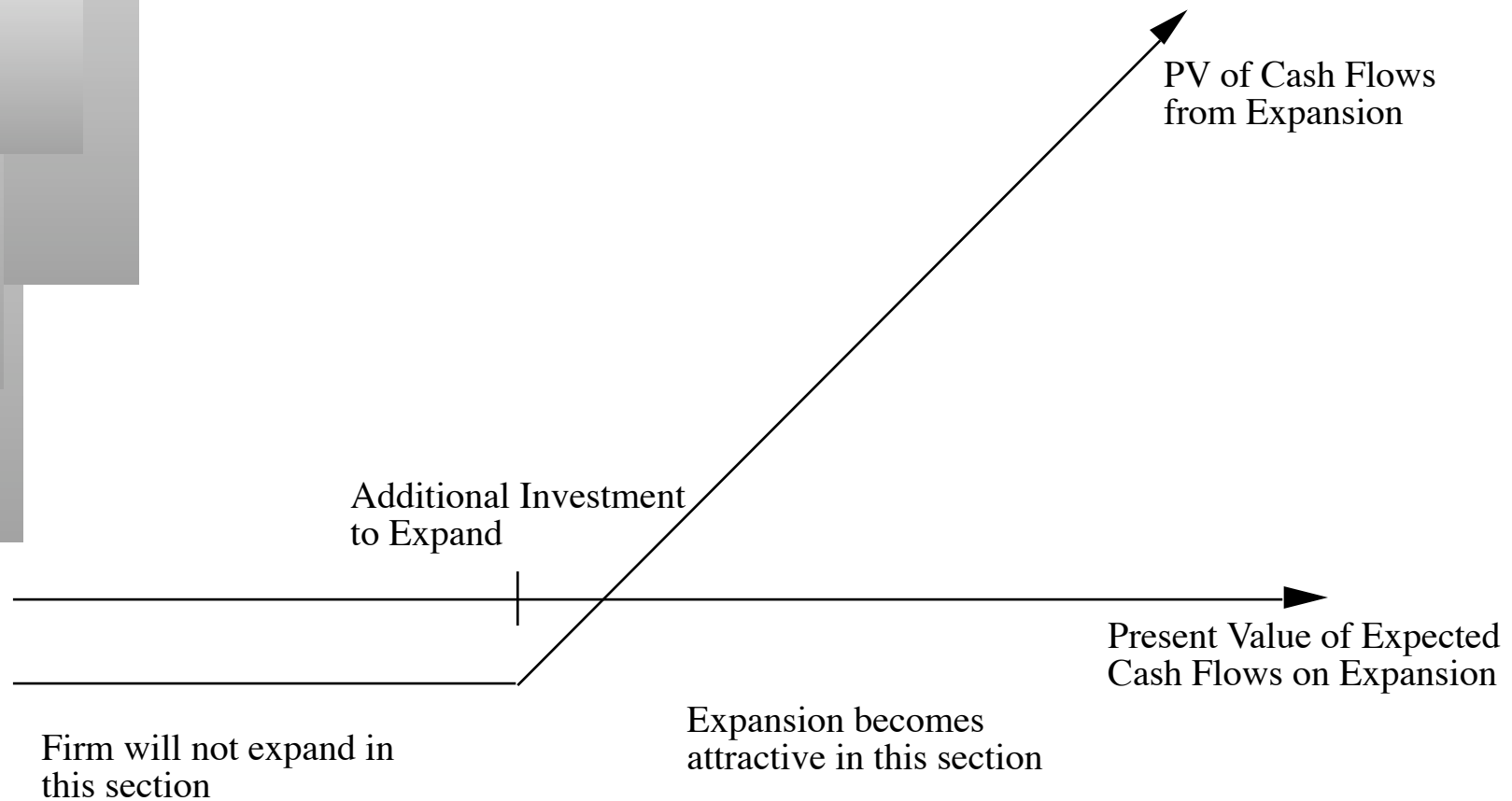

## When does the option have significant economic value?

---

- For an option to have significant economic value, there has to be a restriction on competition in the event of the contingency. In a perfectly competitive product market, no contingency, no matter how positive, will generate positive net present value.
- At the limit, real options are most valuable when you have exclusivity - you and only you can take advantage of the contingency. They become less valuable as the barriers to competition become less steep.

## Exclusivity: Putting Real Options to the Test

---

- **Product Options: Patent on a drug**
  - Patents restrict competitors from developing similar products
  - Patents do not restrict competitors from developing other products to treat the same disease.
- **Natural Resource options: An undeveloped oil reserve or gold mine.**
  - Natural resource reserves are limited.
  - It takes time and resources to develop new reserves
- **Growth Options: Expansion into a new product or market**
  - Barriers may range from strong (exclusive licenses granted by the government - as in telecom businesses) to weaker (brand name, knowledge of the market) to weakest (first mover).



## Determinants of option value

---

- Variables Relating to Underlying Asset
  - Value of Underlying Asset; as this value increases, the right to buy at a fixed price (calls) will become more valuable and the right to sell at a fixed price (puts) will become less valuable.
  - Variance in that value; as the variance increases, both calls and puts will become more valuable because all options have limited downside and depend upon price volatility for upside.
  - Expected dividends on the asset, which are likely to reduce the price appreciation component of the asset, reducing the value of calls and increasing the value of puts.
- Variables Relating to Option
  - Strike Price of Options; the right to buy (sell) at a fixed price becomes more (less) valuable at a lower price.
  - Life of the Option; both calls and puts benefit from a longer life.
- Level of Interest Rates; as rates increase, the right to buy (sell) at a fixed price in the future becomes more (less) valuable.

# The Building Blocks for Option Pricing Models: Arbitrage and Replication

---

- The objective in creating a replicating portfolio is to use a combination of riskfree borrowing/lending and the underlying asset to create the same cashflows as the option being valued.
  - Call = Borrowing + Buying  $\Delta$  of the Underlying Stock
  - Put = Selling Short  $\Delta$  on Underlying Asset + Lending
  - The number of shares bought or sold is called the **option delta**.
- The principles of arbitrage then apply, and the value of the option has to be equal to the value of the replicating portfolio.

# The Binomial Option Pricing Model

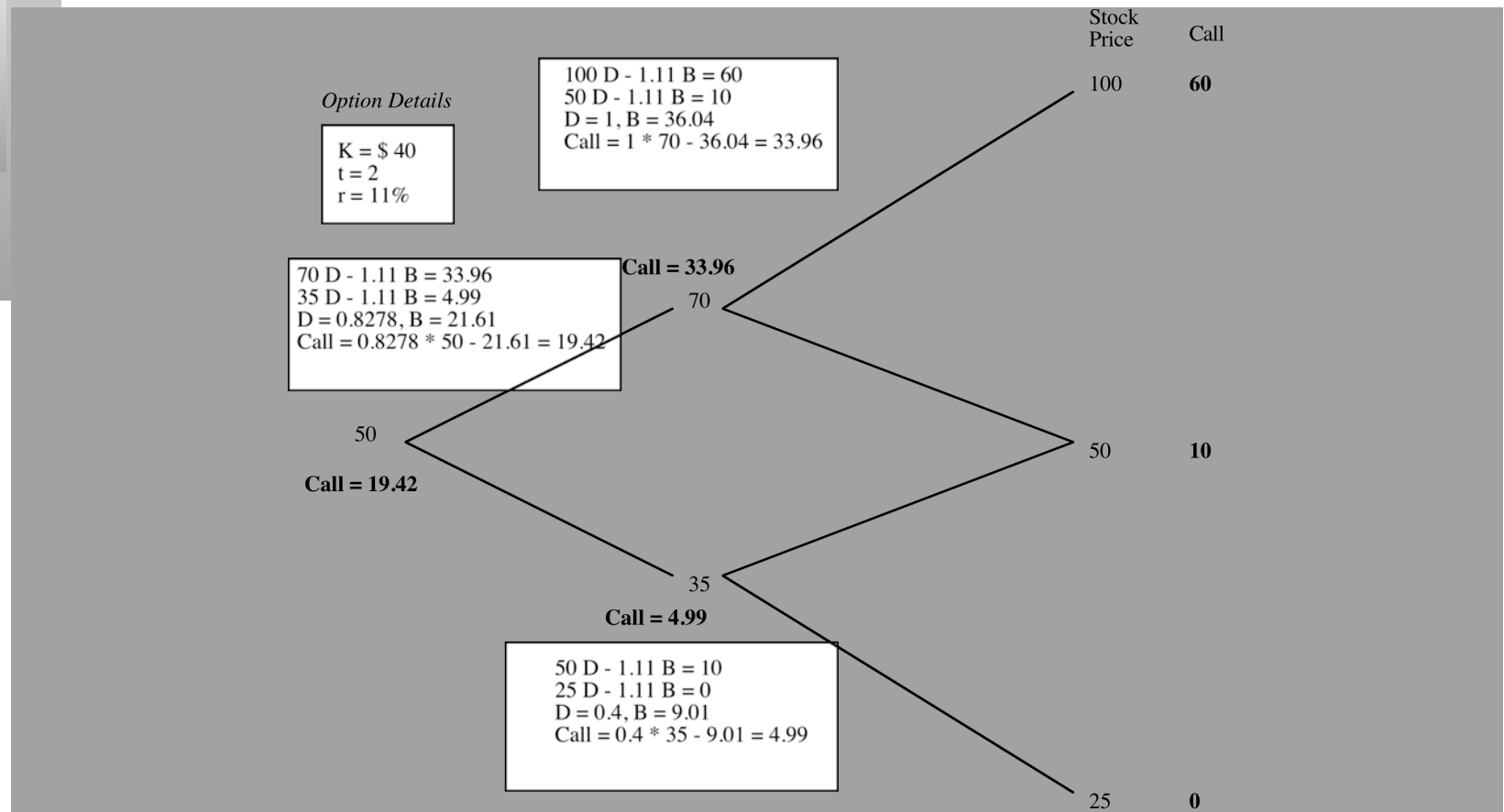

## The Limiting Distributions....

---

- As the time interval is shortened, the limiting distribution, as  $t \rightarrow 0$ , can take one of two forms.
  - If as  $t \rightarrow 0$ , **price changes become smaller**, the limiting distribution is the normal distribution and the **price process is a continuous one**.
  - If as  $t \rightarrow 0$ , **price changes remain large**, the limiting distribution is the poisson distribution, i.e., a **distribution that allows for price jumps**.
- **The Black-Scholes model** applies when the **limiting distribution is the normal distribution**, and explicitly assumes that the price process is continuous and that there are no jumps in asset prices.

## The Black Scholes Model

---

Value of call =  $S N(d_1) - K e^{-rt} N(d_2)$

where,

$$d_1 = \frac{\ln\left(\frac{S}{K}\right) + \left(r + \frac{\sigma^2}{2}\right) t}{\sigma \sqrt{t}}$$

- $d_2 = d_1 - \sigma \sqrt{t}$
- The replicating portfolio is embedded in the Black-Scholes model. To replicate this call, you would need to
  - Buy  $N(d_1)$  shares of stock;  $N(d_1)$  is called the option delta
  - Borrow  $K e^{-rt} N(d_2)$

# The Normal Distribution

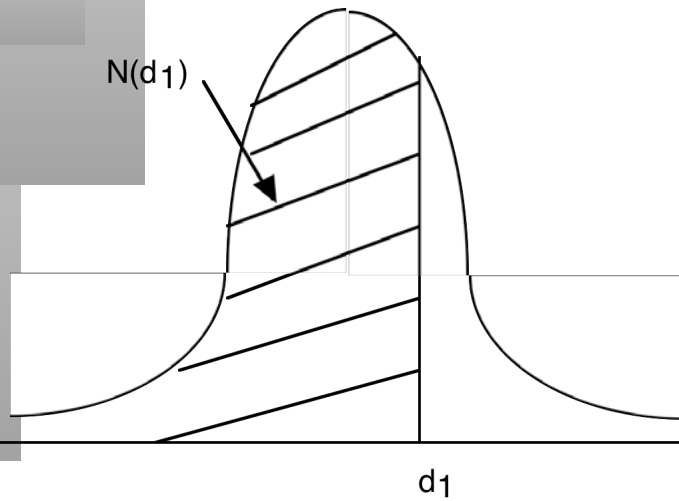

$d$	$N(d)$	$d$	$N(d)$	$d$	$N(d)$
-3.00	0.0013	-1.00	0.1587	1.05	0.8531
-2.95	0.0016	-0.95	0.1711	1.10	0.8643
-2.90	0.0019	-0.90	0.1841	1.15	0.8749
-2.85	0.0022	-0.85	0.1977	1.20	0.8849
-2.80	0.0026	-0.80	0.2119	1.25	0.8944
-2.75	0.0030	-0.75	0.2266	1.30	0.9032
-2.70	0.0035	-0.70	0.2420	1.35	0.9115
-2.65	0.0040	-0.65	0.2578	1.40	0.9192
-2.60	0.0047	-0.60	0.2743	1.45	0.9265
-2.55	0.0054	-0.55	0.2912	1.50	0.9332
-2.50	0.0062	-0.50	0.3085	1.55	0.9394
-2.45	0.0071	-0.45	0.3264	1.60	0.9452
-2.40	0.0082	-0.40	0.3446	1.65	0.9505
-2.35	0.0094	-0.35	0.3632	1.70	0.9554
-2.30	0.0107	-0.30	0.3821	1.75	0.9599
-2.25	0.0122	-0.25	0.4013	1.80	0.9641
-2.20	0.0139	-0.20	0.4207	1.85	0.9678
-2.15	0.0158	-0.15	0.4404	1.90	0.9713
-2.10	0.0179	-0.10	0.4602	1.95	0.9744
-2.05	0.0202	-0.05	0.4801	2.00	0.9772
-2.00	0.0228	0.00	0.5000	2.05	0.9798
-1.95	0.0256	0.05	0.5199	2.10	0.9821
-1.90	0.0287	0.10	0.5398	2.15	0.9842
-1.85	0.0322	0.15	0.5596	2.20	0.9861
-1.80	0.0359	0.20	0.5793	2.25	0.9878
-1.75	0.0401	0.25	0.5987	2.30	0.9893
-1.70	0.0446	0.30	0.6179	2.35	0.9906
-1.65	0.0495	0.35	0.6368	2.40	0.9918
-1.60	0.0548	0.40	0.6554	2.45	0.9929
-1.55	0.0606	0.45	0.6736	2.50	0.9938
-1.50	0.0668	0.50	0.6915	2.55	0.9946
-1.45	0.0735	0.55	0.7088	2.60	0.9953
-1.40	0.0808	0.60	0.7257	2.65	0.9960
-1.35	0.0885	0.65	0.7422	2.70	0.9965
-1.30	0.0968	0.70	0.7580	2.75	0.9970
-1.25	0.1056	0.75	0.7734	2.80	0.9974
-1.20	0.1151	0.80	0.7881	2.85	0.9978
-1.15	0.1251	0.85	0.8023	2.90	0.9981
-1.10	0.1357	0.90	0.8159	2.95	0.9984
-1.05	0.1469	0.95	0.8289	3.00	0.9987
-1.00	0.1587	1.00	0.8413		

# When can you use option pricing models to value real options?

---

- The notion of a replicating portfolio that drives option pricing models makes them most suited for valuing real options where
  - The underlying asset is traded - this yields not only observable prices and volatility as inputs to option pricing models but allows for the possibility of creating replicating portfolios
  - An active marketplace exists for the option itself.
  - The cost of exercising the option is known with some degree of certainty.
- When option pricing models are used to value real assets, we have to accept the fact that
  - The value estimates that emerge will be far more imprecise.
  - The value can deviate much more dramatically from market price because of the difficulty of arbitrage.

## Valuing a Product Patent as an option: Avonex

- Biogen, a bio-technology firm, has a patent on Avonex, a drug to treat multiple sclerosis, for the next 17 years, and it plans to produce and sell the drug by itself. The key inputs on the drug are as follows:

PV of Cash Flows from Introducing the Drug Now =  $S = \$ 3.422$  billion

PV of Cost of Developing Drug for Commercial Use =  $K = \$ 2.875$  billion

Patent Life =  $t = 17$  years    Riskless Rate =  $r = 6.7\%$  (17-year T.Bond rate)

Variance in Expected Present Values =  $\sigma^2 = 0.224$  (Industry average firm variance for bio-tech firms)

Expected Cost of Delay =  $y = 1/17 = 5.89\%$

$d1 = 1.1362$      $N(d1) = 0.8720$

$d2 = -0.8512$      $N(d2) = 0.2076$

Call Value =  $3,422 \exp^{(-0.0589)(17)} (0.8720) - 2,875 (\exp^{(-0.067)(17)} (0.2076)) = \$ 907$   
million



## Valuing an Oil Reserve

---

- Consider an offshore oil property with an estimated oil reserve of 50 million barrels of oil, where the cost of developing the reserve is \$ 600 million today.
- The firm has the rights to exploit this reserve for the next twenty years and the marginal value per barrel of oil is \$12 per barrel currently (Price per barrel - marginal cost per barrel). There is a 2 year lag between the decision to exploit the reserve and oil extraction.
- Once developed, the net production revenue each year will be 5% of the value of the reserves.
- The riskless rate is 8% and the variance in  $\ln(\text{oil prices})$  is 0.03.

## Valuing an oil reserve as a real option

- Current Value of the asset =  $S$  = Value of the developed reserve discounted back the length of the development lag at the dividend yield =  $\$12 * 50 / (1.05)^2 = \$ 544.22$
- (If development is started today, the oil will not be available for sale until two years from now. The estimated opportunity cost of this delay is the lost production revenue over the delay period. Hence, the discounting of the reserve back at the dividend yield)
- Exercise Price = Present Value of development cost =  $\$12 * 50 = \$600$  million
- Time to expiration on the option = 20 years
- Variance in the value of the underlying asset = 0.03
- Riskless rate = 8%
- Dividend Yield = Net production revenue / Value of reserve = 5%

## Valuing the Option

---

- Based upon these inputs, the Black-Scholes model provides the following value for the call:

$$d1 = 1.0359 \quad N(d1) = 0.8498$$

$$d2 = 0.2613 \quad N(d2) = 0.6030$$

- Call Value =  $544.22 \exp^{(-0.05)(20)} (0.8498) - 600 (\exp^{(-0.08)(20)} (0.6030)) = \$ 97.08$  million
- This oil reserve, though not viable at current prices, still is a valuable property because of its potential to create value if oil prices go up.
- Extending this concept, the value of an oil company can be written as the sum of three values:

$$\begin{aligned} \text{Value of oil company} &= \text{Value of developed reserves (DCF valuation)} \\ &+ \text{Value of undeveloped reserves (Valued as option)} \end{aligned}$$

## An Example of an Expansion Option

---

- Ambev is considering introducing a soft drink to the U.S. market. The drink will initially be introduced only in the metropolitan areas of the U.S. and the cost of this “limited introduction” is \$ 500 million.
- A financial analysis of the cash flows from this investment suggests that the present value of the cash flows from this investment to Ambev will be only \$ 400 million. Thus, by itself, the new investment has a **negative NPV of \$ 100 million**.
- If the initial introduction works out well, Ambev **could go ahead with a full-scale introduction to the entire market with an additional investment of \$ 1 billion** any time over the next 5 years. While the current expectation is that the cash flows from having this investment is only \$ 750 million, there is considerable uncertainty about both the potential for the drink, leading to significant variance in this estimate.

## Valuing the Expansion Option

---

- Value of the Underlying Asset (S) = PV of Cash Flows from Expansion to entire U.S. market, if done now = \$ 750 Million
- Strike Price (K) = Cost of Expansion into entire U.S market = \$ 1000 Million
- We estimate the standard deviation in the estimate of the project value by using the annualized standard deviation in firm value of publicly traded firms in the beverage markets, which is approximately 34.25%.
  - Standard Deviation in Underlying Asset's Value = 34.25%
- Time to expiration = Period for which expansion option applies = 5 years

**Call Value= \$ 234 Million**

## One final example: Equity as a Liquidation Option

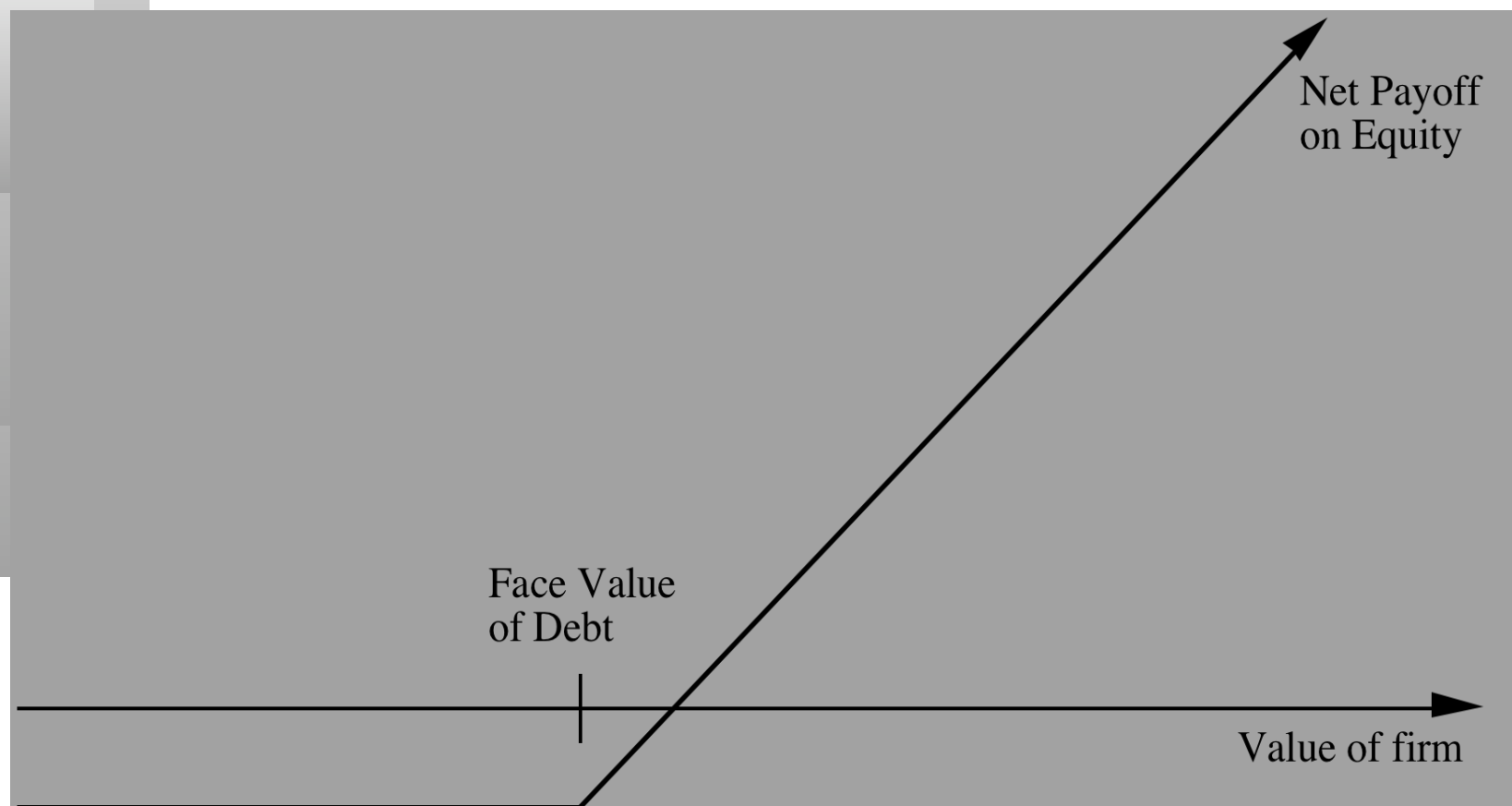

## Application to valuation: A simple example

---

- Assume that you have a firm whose assets are currently valued at \$100 million and that the standard deviation in this asset value is 40%.
- Further, assume that the face value of debt is \$80 million (It is zero coupon debt with 10 years left to maturity).
- If the ten-year treasury bond rate is 10%,
  - how much is the equity worth?
  - What should the interest rate on debt be?

## Valuing Equity as a Call Option

- Inputs to option pricing model
  - Value of the underlying asset =  $S$  = Value of the firm = \$ 100 million
  - Exercise price =  $K$  = Face Value of outstanding debt = \$ 80 million
  - Life of the option =  $t$  = Life of zero-coupon debt = 10 years
  - Variance in the value of the underlying asset =  $\sigma^2$  = Variance in firm value = 0.16
  - Riskless rate =  $r$  = Treasury bond rate corresponding to option life = 10%
- Based upon these inputs, the Black-Scholes model provides the following value for the call:
  - $d1 = 1.5994$                        $N(d1) = 0.9451$
  - $d2 = 0.3345$                        $N(d2) = 0.6310$
- Value of the call =  $100 (0.9451) - 80 \exp^{(-0.10)(10)} (0.6310) = \$75.94$  million
- Value of the outstanding debt =  $\$100 - \$75.94 = \$24.06$  million
- Interest rate on debt =  $(\$ 80 / \$24.06)^{1/10} - 1 = 12.77\%$



## The Effect of Catastrophic Drops in Value

---

- Assume now that a catastrophe wipes out half the value of this firm (the value drops to \$ 50 million), while the face value of the debt remains at \$ 80 million. What will happen to the equity value of this firm?
  - It will drop in value to \$ 25.94 million [ \$ 50 million - market value of debt from previous page]
  - It will be worth nothing since debt outstanding > Firm Value
  - It will be worth more than \$ 25.94 million

## Valuing Equity in the Troubled Firm

---

- Value of the underlying asset =  $S$  = Value of the firm = \$ 50 million
- Exercise price =  $K$  = Face Value of outstanding debt = \$ 80 million
- Life of the option =  $t$  = Life of zero-coupon debt = 10 years
- Variance in the value of the underlying asset =  $\sigma^2$  = Variance in firm value = 0.16
- Riskless rate =  $r$  = Treasury bond rate corresponding to option life = 10%

## The Value of Equity as an Option

---

- Based upon these inputs, the Black-Scholes model provides the following value for the call:
  - $d1 = 1.0515$                        $N(d1) = 0.8534$
  - $d2 = -0.2135$                        $N(d2) = 0.4155$
- Value of the call =  $50 (0.8534) - 80 \exp^{(-0.10)(10)} (0.4155) = \$30.44$  million
- Value of the bond =  $\$50 - \$30.44 = \$19.56$  million
- The equity in this firm drops by, because of the option characteristics of equity.
- This might explain why stock in firms, which are in Chapter 11 and essentially bankrupt, still has value.

## Equity value persists ..

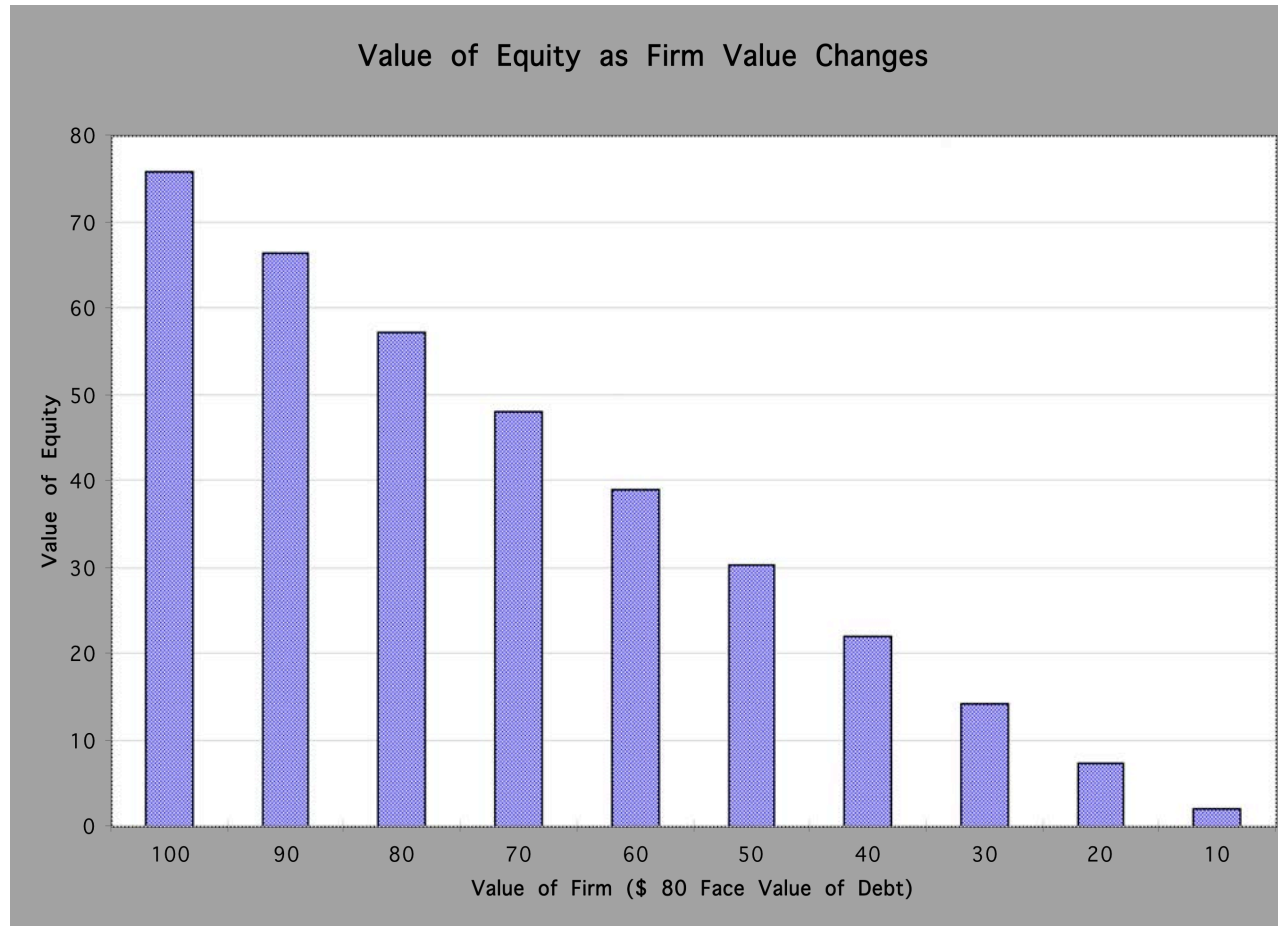

## Obtaining option pricing inputs in the real worlds

Input	Estimation Process
Value of the Firm	<ul style="list-style-type: none"> <li>• Cumulate market values of equity and debt (or)</li> <li>• Value the <u>assets in place</u> using FCFF and WACC (or)</li> <li>• Use cumulated market value of assets, if traded.</li> </ul>
Variance in Firm Value	<ul style="list-style-type: none"> <li>• If stocks and bonds are traded,</li> </ul> $\sigma_{\text{firm}}^2 = w_e^2 \sigma_e^2 + w_d^2 \sigma_d^2 + 2 w_e w_d \rho_{ed} \sigma_e \sigma_d$ <p>where <math>\sigma_e^2</math> = variance in the stock price  <math>w_e</math> = MV weight of Equity  <math>\sigma_d^2</math> = the variance in the bond price      <math>w_d</math> = MV weight of debt</p> <ul style="list-style-type: none"> <li>• If not traded, use variances of similarly rated bonds.</li> <li>• Use average firm value variance from the industry in which company operates.</li> </ul>
Value of the Debt	<ul style="list-style-type: none"> <li>• If the debt is short term, you can use only the face or book value of the debt.</li> <li>• If the debt is long term and coupon bearing, add the cumulated nominal value of these coupons to the face value of the debt.</li> </ul>
Maturity of the Debt	<ul style="list-style-type: none"> <li>• Face value weighted duration of bonds outstanding (or)</li> <li>• If not available, use weighted maturity</li> </ul>

## Valuing Equity as an option - Eurotunnel in early 1998

- Eurotunnel has been a financial disaster since its opening
  - In 1997, Eurotunnel had earnings before interest and taxes of -£56 million and net income of -£685 million
  - At the end of 1997, its book value of equity was -£117 million
- It had £8,865 million in face value of debt outstanding
  - The weighted average duration of this debt was 10.93 years

Debt Type	Face Value	Duration
Short term	935	0.50
10 year	2435	6.7
20 year	3555	12.6
Longer	1940	18.2
<i>Total</i>	<i>£8,865 mil</i>	<i>10.93 years</i>

## The Basic DCF Valuation

---

- The value of the firm estimated using projected cashflows to the firm, discounted at the weighted average cost of capital was £2,312 million.
- This was based upon the following assumptions –
  - Revenues will grow 5% a year in perpetuity.
  - The COGS which is currently 85% of revenues will drop to 65% of revenues in yr 5 and stay at that level.
  - Capital spending and depreciation will grow 5% a year in perpetuity.
  - There are no working capital requirements.
  - The debt ratio, which is currently 95.35%, will drop to 70% after year 5. The cost of debt is 10% in high growth period and 8% after that.
  - The beta for the stock will be 1.10 for the next five years, and drop to 0.8 after the next 5 years.
  - The long term bond rate is 6%.

## Other Inputs

---

- The stock has been traded on the London Exchange, and the annualized std deviation based upon  $\ln$  (prices) is 41%.
- There are Eurotunnel bonds, that have been traded; the annualized std deviation in  $\ln(\text{price})$  for the bonds is 17%.
  - The correlation between stock price and bond price changes has been 0.5. The proportion of debt in the capital structure during the period (1992-1996) was 85%.
  - Annualized variance in firm value  
 $= (0.15)^2 (0.41)^2 + (0.85)^2 (0.17)^2 + 2 (0.15) (0.85)(0.5)(0.41)(0.17) = 0.0335$
- The 15-year bond rate is 6%. (I used a bond with a duration of roughly 11 years to match the life of my option)



## Valuing Eurotunnel Equity and Debt

- Inputs to Model
  - Value of the underlying asset =  $S$  = Value of the firm = £2,312 million
  - Exercise price =  $K$  = Face Value of outstanding debt = £8,865 million
  - Life of the option =  $t$  = Weighted average duration of debt = 10.93 years
  - Variance in the value of the underlying asset =  $\sigma^2$  = Variance in firm value = 0.0335
  - Riskless rate =  $r$  = Treasury bond rate corresponding to option life = 6%
- Based upon these inputs, the Black-Scholes model provides the following value for the call:
  - $d1 = -0.8337$                        $N(d1) = 0.2023$
  - $d2 = -1.4392$                        $N(d2) = 0.0751$
- Value of the call =  $2312 (0.2023) - 8,865 \exp^{(-0.06)(10.93)} (0.0751) = \text{£}122$  million
- Appropriate interest rate on debt =  $(8865/2190)^{(1/10.93)} - 1 = 13.65\%$

## Back to Lemmings...

