



Temporal Resolution of Uncertainty and Dynamic Choice Theory

David M. Kreps; Evan L. Porteus

Econometrica, Volume 46, Issue 1 (Jan., 1978), 185-200.

Stable URL:

<http://links.jstor.org/sici?sici=0012-9682%28197801%2946%3A1%3C185%3ATROUAD%3E2.0.CO%3B2-N>

Your use of the JSTOR archive indicates your acceptance of JSTOR's Terms and Conditions of Use, available at <http://www.jstor.org/about/terms.html>. JSTOR's Terms and Conditions of Use provides, in part, that unless you have obtained prior permission, you may not download an entire issue of a journal or multiple copies of articles, and you may use content in the JSTOR archive only for your personal, non-commercial use.

Each copy of any part of a JSTOR transmission must contain the same copyright notice that appears on the screen or printed page of such transmission.

Econometrica is published by The Econometric Society. Please contact the publisher for further permissions regarding the use of this work. Publisher contact information may be obtained at <http://www.jstor.org/journals/econosoc.html>.

Econometrica

©1978 The Econometric Society

JSTOR and the JSTOR logo are trademarks of JSTOR, and are Registered in the U.S. Patent and Trademark Office. For more information on JSTOR contact jstor-info@umich.edu.

©2003 JSTOR

TEMPORAL RESOLUTION OF UNCERTAINTY AND DYNAMIC CHOICE THEORY

BY DAVID M. KREPS AND EVAN L. PORTEUS¹

We consider dynamic choice behavior under conditions of uncertainty, with emphasis on the timing of the resolution of uncertainty. Choice behavior in which an individual distinguishes between lotteries based on the times at which their uncertainty resolves is axiomatized and represented, thus the result is choice behavior which cannot be represented by a single cardinal utility function on the vector of payoffs. Both descriptive and normative treatments of the problem are given and are shown to be equivalent. Various specializations are provided, including an extension of "separable" utility and representation by a single cardinal utility function.

CONSIDER THE FOLLOWING idealization of a dynamic choice problem with uncertainty. At each in a finite, discrete sequence of times $t=0, 1, \dots, T$, an individual must choose an *action* d_t . His choice is constrained by what we temporarily call the *state* at time t , x_t . Then some random event takes place, determining an immediate *payoff* z_t to the individual and the next state x_{t+1} . The probability distribution of the pair (z_t, x_{t+1}) is determined by the action d_t .

The standard approach in analyzing this problem, which we will call the payoff vector approach, assumes that the individual's choice behavior is representable as follows: He has a von Neumann-Morgenstern utility function U defined on the *vector* of payoffs (z_0, z_1, \dots, z_T) . Each strategy (which is a contingent plan for choosing actions given states) induces a probability distribution on the vector of payoffs. So the individual's choice of action is that specified by any *optimal* strategy, any strategy which maximizes the expectation of utility among all strategies (assuming sufficient conditions so that an optimal strategy exists).

This paper presents an axiomatic treatment of the dynamic choice problem which is more general than the payoff vector approach, but which still permits tractable analysis. The fundamental difference between our treatment and the payoff vector approach lies in our treatment of the *temporal resolution* of uncertainty: In our models, uncertainty is "dated" by the time of its resolution, and the individual regards uncertainties resolving at different times as being different. For example, consider a situation in which a fair coin is to be flipped. If it comes up heads, the payoff vector will be $(z_0, z_1) = (5, 10)$; if it is tails, the vector will be $(5, 0)$. Because $z_0 = 5$ in either case, the coin flip can take place at either time 0 or time 1. It will not matter when the flip occurs to someone who has cardinal utility on the vector of payoffs. But an individual can obey our axioms and prefer either one to the other.

One justification for our approach is the well known "timeless-temporal" or "joint time-risk" feature of some models (usually models which are not "complete"). For example, preferences on income streams which are induced from primitive preferences on consumption streams in general depend upon when the

¹The authors gratefully acknowledge the comments and suggestions of Professors J. M. Harrison and Robert Wilson. This research was supported in part by a grant from the Atlantic Richfield Foundation to the Graduate School of Business, Stanford University.

uncertainty concerning future income resolves (see Spence and Zeckhauser [9]). Our treatment gives a framework within which such effects can be modeled, without overburdening the model with the detail of the primitive preferences.²

The second (and, we believe, the more important) justification is that the relevance of the time of resolution arises naturally in a dynamic choice setting. Following work on the theory of dynamic choice under certainty, such as Hammond [3] and Peleg and Yaari [6], we first consider the individual's choice behavior at each distinct time and then we consider how his choice behavior at different times is related. At a single time, the individual chooses from among actions, identified as probability distributions on immediate payoff and next state pairs, and we assume standard axioms which make these choices representable by a cardinal utility function on such pairs. Then a "temporal consistency" axiom is given which knits together these representations: The result is a preference structure in which the time of resolution may be relevant.

This approach, essentially descriptive, is developed in Sections 1, 2, and 3. In Section 1, formal definitions and constructions of dynamic choice problems, states, and actions are given both mathematically and diagrammatically (as decision trees). Axioms and results for choice behavior at a single time are given in Section 2. We rely on standard theories of cardinal utility (especially Fishburn [1]), so details and proofs are omitted. Section 3 presents the "temporal consistency" axiom and its consequences for representation of choice behavior. Also, the complete representation theorem is illustrated by a simple example.

An alternative approach to preferences in dynamic choice problems, equivalent to that given in Sections 1, 2, and 3, is developed in Section 4. This is a more normative approach which clarifies the issue of temporal resolution of uncertainty and provides an easy comparison with the payoff vector approach. Taken as primitive are the individual's preferences among objects called *temporal lotteries*, from which choices in dynamic choice problems are derived. This formulation parallels the payoff vector approach, where preferences on lotteries are primitive and dynamic choices are induced. Thus the difference between the two is seen to lie in the definition of a temporal lottery, which formalizes the temporal aspect of uncertainty.

In Section 5, we examine the consequences of assuming that the individual prefers earlier resolution of uncertainty to later or vice versa. Then we show that our approach is equivalent to the payoff vector approach if and only if the individual is indifferent to the time of resolution.

In our treatment, choice behavior at time t is allowed to depend on the payoffs received up to time t (z_0, \dots, z_{t-1}). The consequences of assuming that time t choices are independent of previous payoffs are discussed in Section 6, and comparisons are made with similar separability assumptions in the payoff vector approach.

² Briefly, the issue can be illustrated as follows. If in the example the coin flip determines your income for the next two years, you probably prefer to have the coin flipped now, so that you are better able to budget your income for consumption purposes. In later work we will explore the connection between such "induced preferences" and the preference systems analyzed here.

We conclude in Section 7 with some miscellaneous discussion. In particular, relaxation of the "temporal consistency" axiom (in the spirit of Hammond [3] and Peleg and Yaari [6]) is touched upon.

Work similar to that presented here, concerning preferences for "certain-uncertain" pairs, has been done independently by Selden [8].

To keep mathematical detail to a minimum, standard proofs are often just sketched and sometimes omitted, and the axioms employed (particularly our continuity axiom) are stronger than is strictly necessary (but see Section 7).

Much of the content of this study lies in the definitions of dynamic choice problems and temporal lotteries—objects which allow us to "date" uncertainty by the time of its resolution. The reader is forewarned that the mathematical definitions of these objects are quite complex. The diagrammatic representations (as decision trees and probability trees) which follow the mathematical definitions should be read together with the mathematics.

1. MATHEMATICAL AND DIAGRAMMATIC REPRESENTATION

We assume given a finite integer T and, for each time t ($t = 0, 1, \dots, T$), a set Z_t of possible payoffs. We assume that each Z_t is a compact Polish (i.e., complete separable metric) space. A generic element of Z_t is denoted by z_t . Let $Y_1 = Z_0$ and, for $t = 2, \dots, T+1$, let $Y_t = Y_{t-1} \times Z_{t-1}$. The set Y_t is called the set of payoff histories up to (but not including) time t , with generic element $y_t = (z_0, \dots, z_{t-1})$. Note that Y_{T+1} is the set of complete payoff vectors. For $k < t$, $z_k(y_t)$ and $y_k(y_t)$ will denote the projections onto Z_k and Y_k , respectively.

Next, let D_T be the set of Borel probability measures on Z_T , endowed with the Prohorov metric (the metric of weak convergence), and, recursively, let X_t be the set of nonempty closed subsets of D_t , endowed with the Hausdorff metric, and let D_{t-1} be the set of Borel probability measures on $Z_{t-1} \times X_t$, endowed with the Prohorov metric. These constructions are possible because of the following two results from analysis.

LEMMA 1: *If Z and X are compact Polish spaces and D is the set of Borel probability measures on $Z \times X$, then D is a compact Polish space under the Prohorov metric (cf. Parthasarathy [5, Ch. 2, especially Theorems 6.2 and 6.4]).*

LEMMA 2: *If D is a compact Polish space and X is the set of nonempty closed subsets of D , then X is a compact Polish space under the Hausdorff metric (cf. Kuratowski [4]).*

(For notational convenience, we sometimes will write Y_t and y_t when $t = 0$ and X_{t+1} and x_{t+1} when $t = T$. In such cases, Y_0 and X_{T+1} may be thought of as any convenient singleton sets, and D_T as the set of Borel probability measures on $Z_T \times X_{T+1}$.)

DEFINITIONS: A *dynamic choice problem* (over $\{Z_t\}$) from time t to T is any element x_t of X_t . An *action* at time t is any element d_t of D_t .

Recall the description given at the beginning of the paper. At each time t , the individual chooses an action, constrained by what we called the state. The action chosen determines a probability distribution over the next payoff-state pair. In formalizing these notions, we simply define an action as the probability distribution itself. And the term "state" is replaced by "choice problem", which is defined as a closed set of actions. (In the standard terminology of dynamic programming, something like $D_t(x_t)$ is used to denote the set of actions feasible at state x_t . Here, in contrast, x_t itself is that set.)

Our constructions can be represented diagrammatically by *decision trees*. Suppose $T = 1$ and $Z_0 = Z_1 = [0, 10]$. The space D_1 , the space of actions at time 1, is the space of probability distributions on Z_1 . Diagrammatically, $d_1 \in D_1$ is a *chance node* (depicted by a circle) with outcomes in Z_1 . For example, one element in D_1 , called $d_1(a)$, a .6 chance at 2 and a .4 chance at 6, is drawn as in Figure 1.

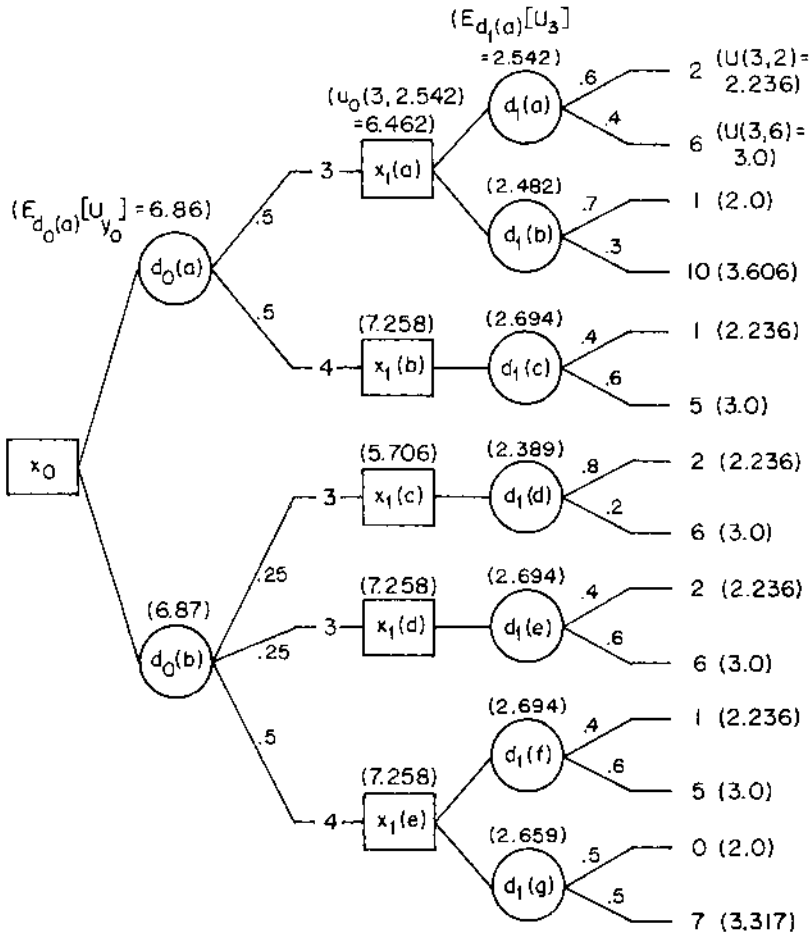

FIGURE 1.

(Ignore the expressions and numbers in the parentheses in Figure 1. These illustrate concepts developed later.) Another element of D_1 , called $d_1(b)$ and also drawn in Figure 1, is a .7 chance at 1 and a .3 chance at 10.

Elements of X_1 , decision problems commencing at time 1, are nonempty closed subsets of D . For example, $x_1(a) = \{d_1(a), d_1(b)\}$ is in X_1 and is depicted as in Figure 1.

Elements of D_0 are probability distributions on $Z_0 \times X_1$. One example is $d_0(a)$ as depicted in Figure 1: This represents equal chances at prizes $(3, x_1(a))$ and $(4, x_1(b))$. Finally, an element x_0 from X_0 is drawn as shown. In all of these drawings, we have depicted only probability distributions with finite supports and closed subsets which are finite. More general cases are clearly encompassed in our mathematical framework.

Notational conventions which we employ include the following: For $z_t \in Z_t$ and $x_{t+1} \in X_{t+1}$, the distribution in D_t which is degenerate at (z_t, x_{t+1}) is denoted simply by (z_t, x_{t+1}) . Given $d_t \in D_t$, we write $d_t \in X_t$ in place of $\{d_t\} \in X_t$ for the (closed) subset of D_t which contains the single element d_t . Combining these, we can write (z_t, d_{t+1}) for both the element of D_t which is degenerate at $(z_t, d_{t+1}) \in Z_t \times X_{t+1}$ and for the singleton set it forms (in X_t). Continuing in this fashion, $(z_t, z_{t+1}, \dots, z_k, x_{k+1})$ will denote the action at time t (element of D_t) which yields, with certainty and without any intervening (nontrivial) choice, payoffs z_j for $j = t, \dots, k$ and the choice problem x_{k+1} at time $k + 1$. It also denotes the singleton set that this action forms.

Each set D_t is a mixture space: For $\alpha \in [0, 1]$ and $d, d' \in D_t$, there is an element in D_t which "is" d with probability α and d' with probability $1 - \alpha$. Let $(\alpha; d, d')$ denote this element.³

For each real valued bounded measurable function f on $Z_t \times X_{t+1}$ and for each $d \in D_t$, the integral of f with respect to the measure d is denoted by $E_d[f]$.

2. CHOICE BEHAVIOR AT A POINT IN TIME

At time t , the individual chooses from a (nonempty closed) subset of D_t . That is, he faces a dynamic choice problem x_t and must choose a member of x_t . His choices are allowed to depend on the history of previous payoffs, y_t , and are assumed to be consistent in the following sense.

AXIOM 2.1: For each t and y_t , the individual's choices from closed subsets of D_t are representable by a complete and transitive binary relation \succsim_{y_t} on D_t .

Note that the individual's choice behavior is assumed to be independent of the dynamic choice problem he is facing; we do not write \succsim_{y_t, x_t} . This constitutes an assumption of "independence of irrelevant alternatives". The induced indifference and strict preference relations are denoted by \sim_{y_t} and $>_{y_t}$, respectively.

³ Formally, for A a Borel measurable subset of $Z_t \times X_{t+1}$, the measure assigned by $(\alpha; d, d')$ to A is $\alpha d(A) + (1 - \alpha)d'(A)$.

AXIOM 2.2 (Continuity): For each t and y_t , \succsim_{y_t} is continuous.⁴

This axiom is stronger than necessary for our eventual objectives, but it is made to keep mathematical detail from dominating the exposition: It partially justifies the restriction of our attention to closed subsets of D_t , because with continuous preferences, an individual may be assumed to be indifferent between any subset of actions and the closure of that subset (but see footnote 5).

AXIOM 2.3 (Substitution): For each t and y_t , if $d, d' \in D_t$ are such that $d \succ_{y_t} d'$, then $(\alpha; d, d'') \succ_{y_t} (\alpha; d', d'')$ for all $\alpha \in (0, 1)$ and for all $d'' \in D_t$.

These three axioms are sufficient to allow the application of the machinery of cardinal utility theory (see, e.g., Fishburn [1, Theorem 10.1]).

LEMMA 3: Axioms 2.1, 2.2, and 2.3 are necessary and sufficient for there to exist, for each y_t , a (bounded) continuous function $U_{y_t}: Z_t \times X_{t+1} \rightarrow \mathbb{R}$ such that for $d, d' \in D_t$, $d \succsim_{y_t} d'$ if and only if $E_d[U_{y_t}] \geq E_{d'}[U_{y_t}]$.

The proof is omitted, but note that in the necessity half, continuity of the U_{y_t} will give Axiom 2.2. The functions U_{y_t} are, of course, unique up to a positive affine transformation.

The function U_{y_t} can be extended to D_t by defining $U_{y_t}(d) = E_d[U_{y_t}]$ and then to X_t by defining $U_{y_t}(x) = \max_{d \in x} U_{y_t}(d)$. Because x is compact and U_{y_t} is continuous on D_t , the maximum is attained. The extension to D_t makes U_{y_t} a (continuous) representation of \succsim_{y_t} , and the extension to X_t makes U_{y_t} a (continuous) representation of the extension of \succsim_{y_t} to X_t by the rule: $x \succsim_{y_t} x'$ if for each $d' \in x'$ there exists a $d \in x$ such that $d \succsim_{y_t} d'$. Using the compactness of x , we can alternatively define: $x \succsim_{y_t} x'$ if there exists $d \in x$ such that for all $d' \in x'$, $d \succsim_{y_t} d'$. Note that \succsim_{y_t} extended to X_t in this manner is complete, transitive, and continuous.⁵

3. TEMPORAL CONSISTENCY AND THE REPRESENTATION THEOREM

Preferences at different times are tied together by the following.

AXIOM 3.1 (Temporal consistency): For all t , $y \in Y_t$, $z \in Z_t$ and $x, x' \in X_{t+1}$, $(z, x) \succsim_y (z, x')$ at time t if and only if $x \succsim_{(y,z)} x'$ at time $t+1$.⁶

The motivation for this key axiom runs as follows. Suppose that at time t with payoff history y , the individual has a choice between the two (degenerate) actions

⁴ That is, for each y_t and d_t , the sets $\{d'_t \in D_t: d'_t \succsim_{y_t} d_t\}$ and $\{d'_t \in D_t: d'_t \preccurlyeq_{y_t} d_t\}$ are both closed (in the weak convergence topology).

⁵ If \succsim_{y_t} is extended to all subsets of D_t by these definitions, then they are not equivalent. The latter yields a transitive but incomplete binary relation, while the former yields a complete and transitive ordering. Note also that the former does not yield indifference between a subset of D_t and its closure.

⁶ Alternatively: $(z, x) \succsim_y (z, x')$ if and only if for each $d' \in x'$ there exists $d \in x$ such that $d \succsim_{(y,z)} d'$.

(z, x) and (z, x') , and he selects (z, x) (so that $(z, x) \succcurlyeq_y (z, x')$). Then the axiom requires that when the payoff history is (y, z) , he cannot strictly prefer x' to x . Doing so would make him "inconsistent" in that he would "regret" his earlier choice. Similarly, if at time $t + 1$ with payoff history (y, z) he weakly prefers x to x' , then he cannot at time t strictly prefer (z, x') to (z, x) when the history is y . For in doing so, he is "inconsistent" as he strictly prefers (z, x') although it leads with certainty to an immediate payoff identical to that of (z, x) and a subsequent decision problem which at time $t + 1$ will not be viewed as better. (An alternative justification for Axiom 3.1, more consistent with the normative approach taken in Section 4, will be given there.)

A consequence of Axiom 3.1 is that every relation \succcurlyeq_{y_t} can be reconstructed from \succcurlyeq_{y_0} as follows: If $y_t = (z_0, \dots, z_{t-1}) \in Y_t$ and $x, x' \in X_t$ are fixed, then $x \succcurlyeq_{y_t} x'$ if and only if $(z_0, \dots, z_{t-1}, x) \succcurlyeq_{y_0} (z_0, \dots, z_{t-1}, x')$. Axiom 3.1 also allows us to tie together the functions U_{y_t} provided by Lemma 3 as follows.

LEMMA 4: *Axioms 2.1, 2.2, 2.3, and 3.1 are necessary and sufficient for there to exist functions U_{y_t} as in Lemma 3 and, for fixed $\{U_{y_t}\}$, unique functions*

$$u_{y_t} : \{(z, \gamma) \in Z_t \times R : \gamma = U_{(y_t, z)}(x) \text{ for some } x \in X_{t+1}\} \rightarrow R$$

which are strictly increasing in their second argument and which satisfy

$$(1) \quad U_{y_t}(z, x) = u_{y_t}(z, U_{(y_t, z)}(x))$$

for all $y \in Y_t$, $z \in Z_t$, and $x \in X_{t+1}$.

PROOF: Assume that the four axioms hold and fix the functions U_{y_t} as provided by Lemma 3. Equation (1) serves to define the u_{y_t} uniquely if we show that $U_{(y_t, z)}(x) = U_{(y_t, z)}(x')$ implies $U_{y_t}(z, x) = U_{y_t}(z, x')$. But this is a trivial consequence of Axiom 3.1. That u_{y_t} is strictly increasing in its second argument is similarly an easy consequence of Axiom 3.1.

Conversely, if functions U_{y_t} and u_{y_t} with the given properties exist, then Axioms 2.1, 2.2, and 2.3 follow from Lemma 3. And if for $y \in Y_t$, $z \in Z_t$ and $x, x' \in X_{t+1}$, $x \succcurlyeq_{(y, z)} x'$, then $U_{(y_t, z)}(x) \succcurlyeq U_{(y_t, z)}(x')$ and, by the monotonicity of u_{y_t} , $U_{y_t}(z, x) = u_{y_t}(z, U_{(y_t, z)}(x)) \succcurlyeq u_{y_t}(z, U_{(y_t, z)}(x')) = U_{y_t}(z, x')$, thus $(z, x) \succcurlyeq_y (z, x')$. Repeating the argument with strict preferences and strict inequalities, using the strict monotonicity of u_{y_t} , yields Axiom 3.1. Q.E.D.

Alternative (and perhaps clearer) forms of equation (1) are

$$(2) \quad U_{y_t}(z, x) = u_{y_t}(z, \max_{d \in x} E_d[U_{(y_t, z)}]) = \max_{d \in x} u_{y_t}(z, E_d[U_{(y_t, z)}]).$$

The role played by the functions u_{y_t} is clear if we write

$$u_{y_t}(z, \gamma) = U_{y_t}(z, U_{(y_t, z)}^{-1}(\gamma)),$$

where Axiom 3.1 guarantees that the choice of $x \in U_{(y_t, z)}^{-1}(\gamma)$ can be made arbitrarily. Thus we see that the u_{y_t} act to "convert" from the utility scale used at

time $t + 1$ to the scale used at time t . As we shall see, this conversion is not simply a “renormalization” but must involve the attitude of the individual to the resolution of uncertainty at time t vs. at time $t + 1$.

Nothing is said in Lemma 4 about the continuity of the u_y . In fact, we can show that each u_y is continuous in its second argument. But unless care is taken in specifying the collection $\{U_{y_t}\}$, continuity of u_y in its first argument may fail. The trick is to pick U_{y_t} which are continuous not only in (z_t, x_{t+1}) but in (y_t, z_t, x_{t+1}) —if this is done then the u_{y_t} are continuous in (y_t, z_t, γ) . As we are about to see, Axiom 3.1 enables us to do this, thus enabling us to give the following “continuous” version of Lemma 4.

THEOREM 1: *Axioms 2.1, 2.2, 2.3, and 3.1 are necessary and sufficient for there to exist a continuous function $U: Y_{T+1} \rightarrow R$ and, for $t = 0, \dots, T - 1$, continuous functions $u_t: Y_t \times Z_t \times R \rightarrow R$, strictly increasing in their third argument, so that if we define $U_{y_T}(z_T) = U(y_T, z_T)$ and, recursively,*

$$(3) \quad U_{y_t}(z_t, x_{t+1}) = \max_{d \in x_{t+1}} u_t(y_t, z_t, E_d[U_{y_t}(z_t)]),$$

then for all y_t and $d, d' \in D_t, d \succcurlyeq_{y_t} d'$ if and only if $E_d[U_{y_t}] \succcurlyeq E_{d'}[U_{y_t}]$. (That is, $\{U_{y_t}\}$ satisfies Lemma 3.)

PROOF: We only sketch the proof. Assuming the four axioms, let U_{y_0} be as guaranteed by Lemma 3. For each y_t , there exist x' and x'' in X_t such that $x' \succcurlyeq_{y_t} x \succcurlyeq_{y_t} x''$ for all $x \in X_t$. Fix the version of U_{y_t} as in Lemma 3 so that $U_{y_t}(x') = U_{y_0}(y_t, x')$ and $U_{y_t}(x'') = U_{y_0}(y_t, x'')$. (Use Axiom 3.1 to ensure that $x' \sim_{y_t} [\text{resp.}, >_{y_t}] x''$ implies $U_{y_0}(y_t, x') = [\text{resp.}, >] U_{y_0}(y_t, x'')$.) Show that for these $\{U_{y_t}\}$, if $y_t(n) \rightarrow y_t$ and $x_t^n \rightarrow x_t$, then $U_{y_t(n)}(x_t^n) \rightarrow U_{y_t}(x_t)$. Now produce $\{u_{y_t}\}$ as in Lemma 4, and show that they are continuous in (y_t, x_t, γ) . Extend them arbitrarily so that they are continuous for all $\gamma \in R$. Then $U(y_{T+1}) = U_{y_T}(x_T)$ and $u_t(y_t, x_t, \gamma) = u_{y_t}(x_t, \gamma)$ will satisfy the theorem.

Conversely, if we have U and u_t as described, we can apply the necessity half of Lemma 4 once we show that the derived U_{y_t} are continuous in (z_t, x_{t+1}) . This is easily done inductively. Q.E.D.

This is our basic representation theorem. Notice that it explicitly involves only U and the functions u_t —these serve to define implicitly the functions U_{y_t} . Our machinations concerning the continuity of the u_t were required for the necessity half of the theorem, in order to ensure that the U_{y_t} derived from U and the u_t are continuous.

To aid in understanding this theorem, it is helpful to “solve” a dynamic choice problem. Consider the problem x_0 depicted in Figure 1, where $T = 1$ and $Z_0 = Z_1 = [0, 10]$, and an individual whose choice behavior is represented by $U(z_0, z_1) = (z_0 + z_1)^{1/2}$ and $u_0(z_0, \gamma) = \gamma^2$ (for $\gamma \geq 0$). Analysis of this problem is given in Figure 1. First, $U_{y_1}(z_1) = U(y_1, z_1)$ is computed for each “complete branch”. For the uppermost branch where $(z_0, z_1) = (3, 2)$, we have $U(3, 2) =$

2.236. After computing each of these, $E_{d_1}[U_{y_1}]$ is computed for each $d_1 \in D_1$. For example, $E_{d_1(a)}[U_{(3)}] = (.6)(2.236) + (.4)(3.) = 2.542$. Similarly, $E_{d_1(b)}[U_{(3)}] = 2.482$. Thus $d_1(a) >_{(3)} d_1(b)$ —at time 1, when $y_1 = (3)$ and the individual faces the problem $x_1(a)$, he chooses action $d_1(a)$. And therefore $U_{(3)}(x_1(a)) = \max_{d \in x_1(a)} U_{(3)}(d) = 2.542$. Now we can use equation (3) to compute $U_{y_0}(3, x_1(a)) = u_0(3, 2.542) = (2.542)^2 = 6.462$. This is done for each $x_1 \in X_1$, with values obtained as indicated. Now $E_d[U_{y_0}]$ is computed for each $d \in D_0$; we find $E_{d_0(a)}[U_{y_0}] = 6.86$ and $E_{d_0(b)}[U_{y_0}] = 6.87$. Thus $d_0(b) >_{y_0} d_0(a)$. At time 0, action $d_0(b)$ is taken.

4. TEMPORAL RESOLUTION OF UNCERTAINTY AND TEMPORAL LOTTERIES

Consider the dynamic choice problem depicted in Figure 2, which corresponds to the following story: A fair coin is to be flipped and based on the outcome, the individual either receives payoffs $(z_0, z_1) = (5, 0)$ or $(5, 10)$. Since $z_0 = 5$ in both cases, it is feasible to have the coin flipped either at $t = 1$ (which is $d_0(a)$) or at $t = 0$ (which is $d_0(b)$). This individual obeys the four axioms of Sections 2 and 3, and his choice behavior is represented by U and u_0 as given in the previous example. We calculate $E_{d_0(a)}[U_{y_0}] = 9.33$ and $E_{d_0(b)}[U_{y_0}] = 10$, so he strictly prefers to have the coin flipped at $t = 0$, as shown in the figure. But suppose his choices were represented by U as above and $u_0(z_0, \gamma) = \gamma^{1/2}$ (for $\gamma > 0$). Then $E_{d_0(a)}[U_{y_0}] = 1.748$ and $E_{d_0(b)}[U_{y_0}] = 1.732$, and he strictly prefers to have the coin flipped at $t = 1$. Obviously, the four axioms have not resulted in von Neumann-Morgenstern utility on the vector of payoffs, as any individual whose choice behavior is representable in that manner will be indifferent between $d_0(a)$ and $d_0(b)$.

In order to compare our treatment with the payoff vector approach, it is helpful to recast our treatment in a different but equivalent form. This equivalent form resembles the payoff vector approach in which one takes as primitive the individual's preferences on the space of *lotteries* of payoff vectors, and from these preferences one induces choices in dynamic choice problems. We define objects called *temporal lotteries* in which uncertainty is "dated" by the time of its

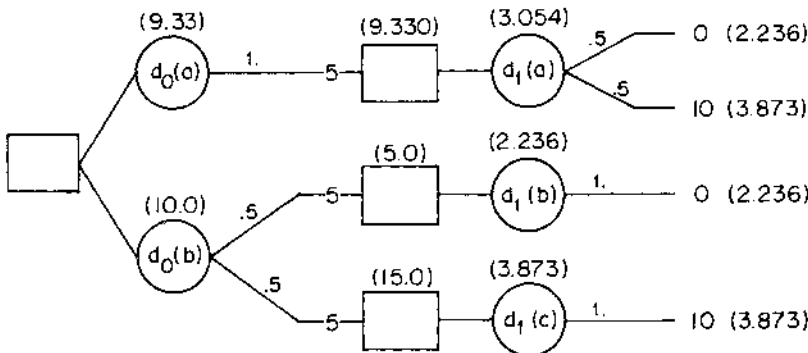

FIGURE 2.

resolution. (Temporal lotteries form a subset of the space of dynamic choice problems, namely dynamic choice problems where all choices are trivial. They are depicted by probability trees.) Axioms are given for the individual's preferences on the space of temporal lotteries and a representation theorem is proved. Then we show that if choice behavior in dynamic choice problems is induced in a natural way from the individual's preferences on the space of temporal lotteries, the choice behavior obtained satisfies the four axioms of Sections 2 and 3. Conversely, if one takes as primitive dynamic choice behavior as described in Sections 2 and 3, then the induced preferences on the subspace of temporal lotteries satisfy the three axioms of this section.

Let $D_T^* = D_T$ and, recursively, let X_t^* be the set of all singleton subsets of D_t^* , and let D_{t-1}^* be the set of all Borel probability measures on $Z_{t-1} \times X_t^*$. Elements of D_t^* and X_t^* correspond to decision trees (beginning, respectively, with time t chance and choice nodes) where all choice nodes are singleton. If the choice nodes were suppressed, elements of D_t^* (and X_t^*) when drawn would be *probability trees*. The degenerate choice nodes are not suppressed, however, so that we are able to relate these objects with the previously defined actions and dynamic choice problems. Clearly, $D_t^* \subseteq D_t$ and $X_t^* \subseteq X_t$.

Next, let $P_t(y_t)$ be the subset of D_0^* of decision trees whose chance nodes for times $k = 0, 1, \dots, t-1$ are degenerate with immediate payoffs given by y_t . Verbally, $d_0 \in D_0^*$ is in $P_t(y_t)$ (for some y_t) if no uncertainty resolves in d_0 before time t . An element of $P_t(y_t)$ is denoted by $p_t = (y_t, d_t)$ where $d_t \in D_t^*$. Note that if $y_k(y_t) = y_k$ for $k \leq t$, then $P_k(y_k) \supseteq P_t(y_t)$. Also, $P_0(y_0) = D_0^*$.

DEFINITIONS: Elements of D_0^* are called *temporal lotteries*. Elements of $P_t(y_t)$ (for any t and y_t) are called *temporal lotteries resolving from time t* .

Examples can be culled from Figure 2. Both $d_0(a)$ and $d_0(b)$ are in D_0^* and $d_1(a)$, $d_1(b)$, and $d_1(c)$ are in D_1^* . In $d_0(a)$, there is no uncertainty until time $t = 1$ and the first payoff is 5, so $d_0(a) \in P_1(5)$. Also, $d_0(a)$ can be written $(5, d_1(a))$. In $d_0(b)$, there is no uncertainty concerning z_0 but $d_0(b) \notin P_1(5)$ because there is uncertainty which is resolved at time 0 concerning x_1 .

The space $P_0(y_0) = D_0^*$ is a mixture space; if p and p' are in D_0^* and $\alpha \in [0, 1]$, then $(\alpha; p, p')$ is in D_0^* . But suppose p and p' are also in $P_t(y_t)$ for some y_t . Write $p = (y_t, d_t)$ and $p' = (y_t, d'_t)$ for $d_t, d'_t \in D_t^*$. For $\alpha \in [0, 1]$, we have $(\alpha; d_t, d'_t)$ is in D_t^* , thus $(y_t, (\alpha; d_t, d'_t))$ is in $P_t(y_t)$. Note carefully the difference— $(\alpha; p, p')$ is p and p' "mixed at time 0", while $(y_t, (\alpha; d_t, d'_t))$ is p and p' "mixed at time t ". A final bit of notation: For p and p' in $P_t(y_t)$, $\alpha \in [0, 1]$ and $k \leq t$, let $(k, \alpha; p, p')$ denote p and p' "mixed at time k " (which is in $P_k(y_k(y_t))$). In this new notation, $(\alpha; p, p')$ is denoted by $(0, \alpha; p, p')$. Of course, $(t, \alpha; p, p')$ does not make sense unless both p and p' are in $P_t(y_t)$ for some y_t .

For example, two elements of $P_1(5)$ are $p(a) = (5, 0)$ ($z_0 = 5$ and $z_1 = 0$, both with certainty) and $p(b) = (5, 10)$. We can construct $(1, .5; p(a), p(b))$ which is $d_0(a)$ and $(0, .5; p(a), p(b)) = d_0(b)$ in Figure 2. The only difference between $d_0(a)$ and $d_0(b)$ is when the uncertainty resolves.

Taken as primitive in this approach is a binary relation on D_0^* which represents the individual's (weak) preferences on D_0^* . It is denoted by \succsim , with $>$ and \sim denoting the induced strict preference and indifference relations, respectively. Three axioms concerning the relation \succsim are posed.

AXIOM 4.1: *The relation \succsim is complete and transitive on D_0^* .*

AXIOM 4.2 (Continuity): *The relation \succsim is continuous on D_0^* .*

AXIOM 4.3 (Temporal substitution): *If $p, p' \in P_t(y_t)$ satisfy $p > p'$, then $(t, \alpha; p, p'') > (t, \alpha; p', p'')$ for all $\alpha \in (0, 1)$ and $p'' \in P_t(y_t)$.*

Axioms 4.1 and 4.2 are clearly analogous to Axioms 2.1 and 2.2, respectively. Axiom 4.3 is roughly analogous to Axiom 2.3, although we shall see that Axiom 3.1 (temporal consistency) and Axiom 2.3 are needed to derive 4.3. We do not give a temporal consistency axiom in our second approach, as we have only one binary relation, \succsim , instead of a collection of relations \succsim_{y_t} .⁷

THEOREM 2: *The existence of a relation \succsim on D_t^* satisfying Axioms 4.1, 4.2, and 4.3 is necessary and sufficient for there to exist continuous functions $U^*: Y_{T+1} \rightarrow R$ and $u_t^*: Y_t \times Z_t \times R \rightarrow R$ ($t = 0, \dots, T-1$) such that (i) each u_t^* is strictly increasing in its third argument, and (ii) if one defines $U_{y_T}^*: Z_T \rightarrow R$ by $U_{y_T}^*(z_T) = U^*(y_T, z_T)$ and, recursively, $U_{y_t}^*: Z_t \times X_{t+1} \rightarrow R$ by*

$$(4) \quad U_{y_t}^*(z_t, d_{t+1}) = u_t^*(y_t, z_t, E_{d_{t+1}}[U_{(y_t, z_t)}^*]),$$

then for $p = (y_t, d_t)$ and $p' = (y_t, d'_t)$ in $P_t(y_t)$, $p \succsim p'$ if and only if $E_{d_t}[U_{y_t}^] \succsim E_{d'_t}[U_{y_t}^*]$.*

PROOF: The proof is obtained by mimicking the proofs of Lemmas 3 and 4 and Theorem 1. Note that Axiom 4.3 acts as the usual substitution principle on each $p_t(y_t)$ taken separately, allowing us to construct the functions $U_{y_t}^*$. Q.E.D.

Given a relation \succsim on D_0^* which satisfies Axioms 4.1, 4.2, and 4.3, we are able to use the representation given by Theorem 2 to induce choice behavior in dynamic choice problems which satisfies Axioms 2.1, 2.2, 2.3, and 3.1 as follows.

COROLLARY 1: *Given a relation \succsim on D_0^* which satisfies Axioms 4.1, 4.2, and 4.3 and functions U^* and u_t^* representing \succsim in the sense of Theorem 2, define $U_{y_T}: Z_T \rightarrow R$ by $U_{y_T}(z_T) = U^*(y_T, z_T)$, and, recursively, define $U_{y_t}: Z_t \times X_{t+1} \rightarrow R$ by*

$$(5) \quad U_{y_t}(z_t, x_{t+1}) = \max_{d \in x_{t+1}} u_t^*(y_t, z_t, E_d\{U_{(y_t, z_t)}\}).$$

⁷ Alternatively, we could begin with relations \succsim_{y_t} on D_t^* and include a "consistency" axiom of the form: \succsim_{y_t} on D_t^* "agrees" with \succsim_{y_0} on $P_t(y_t)$. Cf. footnote 8.

If binary relations \succsim_{y_t} on D_t are defined by $d_t \succsim_{y_t} d'_t$ if $E_{d_t}[U_{y_t}] \succsim E_{d'_t}[U_{y_t}]$, then the collection $\{\succsim_{y_t}\}$ satisfies Axioms 2.1, 2.2, 2.3, and 3.1. Furthermore, the relations \succsim_{y_t} defined by equation (5) are determined by \succsim and do not otherwise depend on the particular functions U^* and u_t^* used to represent \succsim . Finally, \succsim_{y_0} restricted to D_0^* coincides with \succsim .

PROOF: That \succsim_{y_t} satisfies Axioms 2.1, 2.2, 2.3, and 3.1 follows from the necessity half of Theorem 1. A straightforward argument by backward induction yields the last two statements. Q.E.D.

The following is the converse to Corollary 1.

COROLLARY 2: Given relations \succsim_{y_t} on the sets D_t which satisfy Axioms 2.1, 2.2, 2.3, and 3.1, if we let \succsim denote the restriction of \succsim_{y_0} to D_0^* , then \succsim satisfies Axioms 4.1, 4.2, and 4.3. Furthermore, if functions U^* and u_t^* represent \succsim in the sense of Theorem 2, and from U^* and u_t^* we construct functions U_{y_t} via equation (5), then the functions U_{y_t} represent the relations \succsim_{y_t} in the sense of Theorem 1.

The second part of the corollary can be rephrased as follows: The individual's preferences for temporal lotteries completely and unambiguously specify his dynamic choice behavior, if that choice behavior satisfies the first four axioms.

PROOF: Axioms 2.1 and 2.2 trivially imply Axioms 4.1 and 4.2, respectively. To show Axiom 4.3, let $p = (y_t, d)$, $p' = (y_t, d')$, and $p'' = (y_t, d'')$ be from $P_t(y_t)$ and let $\alpha \in (0, 1)$. If $p > p'$, then by Axiom 3.1 $d >_{y_t} d'$. By Axiom 2.3, this yields $(\alpha; d, d'') >_{y_t} (\alpha; d', d'')$ and so, by Axiom 3.1 again, $(t, \alpha; p, p'') = (y_t, (\alpha; d, d'')) > (y_t, (\alpha; d', d'')) = (t, \alpha; p', p'')$. For the second part, note that if functions U and u_t represent the relations \succsim_{y_t} in the sense of Theorem 1, then they represent \succsim in the sense of Theorem 2. The second part of Corollary 1 therefore applies. Q.E.D.

Corollaries 1 and 2 establish the equivalence between the two treatments we have given (assuming that equation (5) is used to define the relations \succsim_{y_t} from \succsim). However, we feel that there is a significant philosophical difference between them: The treatment of Sections 1, 2, and 3 is felt to be descriptive in comparison with the normative approach of taking preferences on D_0^* as primitive. In particular, compare the roles played by Axiom 3.1 in the first treatment and by equation (5) in the second. From a normative point of view, the individual's preferences for dynamic choice problems should be derived from the "prospects" for future payoffs that the problems represent according to the individual's preferences for temporal lotteries.⁸ Equation (5) is explicitly this derivation. But in a descriptive theory, one's choices at the various times for lotteries on $Z_t \times X_{t+1}$

⁸ In this normative approach, it seems natural to begin with a single, perforce consistent, preference relation on the space of temporal lotteries, although this rules out consideration of changing preferences as in Hammond [3] and Peleg and Yaari [6].

are the primitive data. One might interpret Axiom 3.1, as saying that the revealed "value" that the individual attaches to the x_t is derived from the "prospects" for future payoffs that the x_t entail. But we prefer to view Axiom 3.1 as saying only that revealed choice behavior at different times is consistent, without attaching this sort of normative meaning to it.

Comparisons with the payoff vector approach are most easily made by examining our second treatment. The fundamental difference is in the (often implicit) "reduction of compound lotteries" assumption in the payoff vector approach. In many treatments (e.g., Herstein and Milnor [2]), the space from which the individual is choosing is the space of lotteries on Y_{T+1} , so a compound lottery is identified implicitly by the simple lottery that it reduces to, no matter when its uncertainty resolves. In other treatments (e.g., Raiffa [7]), this is made explicit (in Raiffa, it is derived from his "Fundamental Observation")—the individual chooses from among compound lotteries but is indifferent between a compound lottery and the simple lottery that it reduces to. But in our treatment, the space of objects being chosen from is the space of temporal lotteries. There is a well defined notion of the time at which uncertainty resolves, and although there is an implicit "reduction of compound lotteries" axiom for uncertainty that resolves at a single time, there is no axiom which says or implies that uncertainties at two different times are equivalent or can be "reduced". Instead, if p and p' are from $P_t(y_t)$ for some $t \geq 1$ and some y_t , the individual distinguishes between $(t, \alpha; p, p')$ and $(t - 1, \alpha; p, p')$, saying that the uncertainty resolves one period later in the first than in the second, and he may thereupon prefer one to the other.

5. PREFERENCES FOR EARLIER OR LATER RESOLUTION OF UNCERTAINTY

In this section, we give the consequences for our representation of assuming that the individual prefers earlier resolution of uncertainty to later or vice versa. Also, we give the additional necessary condition to reduce our treatment to the payoff vector approach—that when uncertainty resolves is unimportant to the individual.

THEOREM 3. *Suppose the individual's choice behavior obeys Axioms 2.1, 2.2, 2.3, and 3.1 and, as guaranteed by Theorem 1, his choice behavior is represented by functions U and u_t . Construct $\{U_{y_t}\}$ and, for each t, y_t , and z_t , let $\Gamma(y_t, z_t) = \{\gamma \in R : \gamma = U_{(y_t, z_t)}(x_{t+1}) \text{ for some } x_{t+1} \in X_{t+1}\}$. (The set $\Gamma(y_t, z_t)$ is the set of values γ which are "relevant" for $u_t(y_t, z_t, \cdot)$.) Then for fixed $t < T, y_t$, and z_t ,*

$$(t, \alpha; p, p') \geq [\text{resp., } \leq, \sim](t + 1, \alpha; p, p')$$

for all $\alpha \in [0, 1]$, and $p, p' \in P_{t+1}(y_t, z_t)$ if and only if $u_t(y_t, z_t, \gamma)$ is convex [resp., concave, affine] in γ for all $\gamma \in \Gamma(y_t, z_t)$.

PROOF: Fix t, y_t , and z_t , and let $\gamma, \gamma' \in \Gamma(y_t, z_t)$ with $\gamma = U_{(y_t, z_t)}(d)$ and $\gamma' = U_{(y_t, z_t)}(d')$ where $d, d' \in D_{t+1}^*$. (A standard argument shows that $d, d' \in D_{t+1}^*$ can be

assumed.) Let $p = (y_t, z_t, d)$ and $p' = (y_t, z_t, d')$. Then for $\alpha \in [0, 1]$,

$$\begin{aligned} (t, \alpha; p, p') &\succcurlyeq (t+1, \alpha; p, p') \quad \text{if and only if} \\ U_{y_t}((\alpha; (z_t, d), (z_t, d'))) &\succcurlyeq U_{y_t}(z_t, (\alpha; d, d')) \quad \text{if and only if} \\ \alpha U_{y_t}(z_t, d) + (1-\alpha)U_{y_t}(z_t, d') &\succcurlyeq U_{y_t}(z_t, (\alpha; d, d')) \quad \text{if and only if} \\ \alpha u_t(y_t, z_t, \gamma) + (1-\alpha)u_t(y_t, z_t, \gamma') &\succcurlyeq u_t(y_t, z_t, \alpha\gamma + (1-\alpha)\gamma'). \end{aligned}$$

Repeating this argument for \preccurlyeq and \sim gives the result. Q.E.D.

The necessary and sufficient conditions for $u_t(y_t, z_t, \gamma)$ to be strictly convex or concave for $\gamma \in \Gamma(y_t, z_t)$ are easy extensions of these results and are left to the reader. Also, it is possible to combine this notion of preference for earlier or later resolution of uncertainty with the standard notions of risk averse or risk seeking preferences to obtain results such as: If the individual is risk averse for lotteries resolving entirely at time 0 and if he prefers earlier resolution of uncertainty, then he is risk averse for lotteries which resolve at any time. (Results of this sort will be given in subsequent work.)

Returning momentarily to the example at the beginning of Section 4, we can see Theorem 3 at work. If $u_0(z_0, \gamma) = \gamma^2$ (for $\gamma \geq 0$), then u_0 is convex and so, as verified computationally, the individual prefers that the coin flip take place at $t = 0$. But if $u_0(z_0, \gamma) = \gamma^{1/2}$, u_0 is concave, and he prefers the flip at $t = 1$.

If we assume that the timing of resolution is inconsequential to the individual, we obtain the payoff vector approach.

AXIOM 5.1: For all $t \geq 1$, $y_t, \alpha \in [0, 1]$ and $p, p' \in P_t(y_t)$, $(t, \alpha; p, p') \sim (t-1, \alpha; p, p')$.⁹

COROLLARY 3: Axioms 2.1, 2.2, 2.3, 3.1, and 5.1 are necessary and sufficient for the individual's choices to be representable by a single (von Neumann-Morgenstern) utility function U on Y_{T+1} , by which we mean: In the representation of Theorem 1, we can take $u_t(y_t, z_t, \gamma) = \gamma$ for all t, y_t , and z_t .

PROOF: We can select U and u_t in Theorem 1 so that for the induced U_{y_t} , $U_{y_t}(x'_t) = U_{y_0}(y_t, x'_t)$ and $U_{y_t}(x''_t) = U_{y_0}(y_t, x''_t)$ where x'_t and x''_t may depend on y_t and $x'_t \succ_{y_t} x''_t$ unless \succ_{y_t} is void. (See the proof of Theorem 1.) But then for all x_t , $U_{y_t}(x_t) = U_{y_0}(y_t, x_t)$, because Theorem 3 and Axiom 5.1 yield that $U_{y_0}(y_t, \cdot)$ is a (positive) affine transformation of $U_{y_t}(\cdot)$, and they agree at two distinct values (except in the trivial case, for which the proof is obvious). And as u_t must satisfy $u_t(y_t, z_t, U_{(y_t, z_t)}(x_{t+1})) = U_{y_t}(z_t, x_{t+1})$, we have $u_t(y_t, z_t, U_{y_0}(y_t, z_t, x_{t+1})) = U_{y_0}(y_t, z_t, x_{t+1})$, or $u_t(y_t, z_t, \gamma) = \gamma$.

The necessity half is a trivial consequence of Theorem 3. Q.E.D.

6. PAYOFF HISTORY INDEPENDENCE

In this section we consider the consequences of assuming that the individual's choices at time t are independent of past payoffs.

⁹ It suffices to have the stated property for only the most and least preferred elements of $P_t(y_t)$, instead of for all $p, p' \in P_t(y_t)$.

AXIOM 6.1: If $d, d' \in D_t$ satisfy $d \succcurlyeq_{y_t} d'$ for some y_t , then $d \succcurlyeq_{y_t} d'$ for all $y_t \in Y_t$.

COROLLARY 4: Axioms 2.1, 2.2, 2.3, 3.1, and 6.1 are necessary and sufficient for there to exist continuous functions $U: Z_T \rightarrow R$ and $u_t: Z_t \times R \rightarrow R$ ($t = 0, \dots, T-1$) such that the u_t are strictly increasing in their second argument and, if we define $U_T: Z_T \rightarrow R$ by $U_T \equiv U$ and, recursively, $U_t: Z_t \times X_{t+1} \rightarrow R$ by $U_t(z, x) = \max_{d \in x} u_t(z, E_d[U_{t+1}])$, then for $d, d' \in D_t$, $d \succcurlyeq_{y_t} d'$ for all y_t if and only if $E_d[U_t] \succcurlyeq_{E_{d'}}[U_t]$.

PROOF: Suppose the five axioms hold. Arbitrarily select $y'_T \in Y_T$ and let $y'_t = y_t(y'_T)$. Obtain $U': Y_{T+1} \rightarrow R$ and $u'_t: Y_t \times Z_t \times R \rightarrow R$ as in Theorem 1. Set $U(z_T) = U'(y'_T, z_T)$ and $u_t(z_t, \gamma) = u'_t(y'_t, z_t, \gamma)$. Then inductively, $U_t(z_t, x_{t+1}) = U'_t(z_t, x_{t+1})$. Applying Axiom 6.1 gives the result. The necessity half is trivial.

Q.E.D.

Of course, we cannot combine Corollaries 3 and 4 to say that if Axioms 2.1, 2.2, 2.3, 3.1, 5.1, and 6.1 all hold, then the individual's choices can be represented by $U: Z_T \rightarrow R$ and $u_t: Z_t \times R \rightarrow R$ where $u_t(z_t, \gamma) = \gamma$. Each proof required that particular versions of the U_{y_t} be selected, and these versions may differ. Instead, we have the well known result for separable cardinal utility: If all the axioms hold, choices can be represented by $U: Z_T \rightarrow R$ and $u_t: Z_t \times R \rightarrow R$ where $u_t(z_t, \gamma) = a_t(z_t) + b_t(z_t) \cdot \gamma$, for $b_t(z_t) > 0$.

7. DISCUSSION

The feature that most clearly distinguishes our treatment from previous work is its focus on the temporal aspect of uncertainty. Our approach to dynamic choice problems and temporal lotteries explicitly models uncertainty as "attached" to a certain time. Although reduction of compound uncertainty at a single time is implicit, reduction of uncertainty at several different times is not allowed. Our treatment is no more nor less than an application of standard cardinal utility theory to this expanded conception of a "mixture space". (Note that if attention is restricted to choice problems/temporal lotteries where all uncertainty resolves at $t = 0$, there is a single "mixing" of prizes and one gets the payoff vector approach.)

It is this temporal character of uncertainty which has led to our results and not "temporal inconsistency" (in the sense of Hammond [3] or Peleg and Yaari [6]). This is clear from Theorem 2 and Corollary 1, where we show that our axioms are equivalent to the supposition of a single (perforce consistent) preference relation, albeit on the larger domain of temporal lotteries. It is possible, however, to give analyses of "inconsistent choice behavior" in the spirit of the cited papers, by relaxing Axiom 3.1. (Equivalently, one can posit for each t and y_t preference relations \succcurlyeq_{y_t} on D_t^* which are not consistent and legislate, in place of equation (5), "naive" or "sophisticated" choice behavior. In either approach, the troublesome issue of "ties" for sophisticated choice comes up exactly as in the analyses of inconsistent choice behavior under certainty.)

We conclude with two technical points. The assumptions that each Z_t is

compact and that choices/preferences are continuous are more necessary for mathematical reasons than may be apparent. If Z_T , say, is not compact, then D_T will be Polish but also not compact and X_T as topologized will not be separable. And if \succsim_{y_T} is not continuous, then we cannot even partially justify looking only at closed subsets of D_T in forming X_T , so that topologizing X_T is difficult. Relaxing either or both of these assumptions is not fatal, but the required constructions are much more involved.

Stanford University

Manuscript received August, 1976; revision received February, 1977.

REFERENCES

- [1] FISHBURN, PETER C.: *Utility Theory for Decision Making*. New York: John Wiley and Sons, 1970.
- [2] HERSTEIN, I. N., AND JOHN MILNOR: "An Axiomatic Approach to Measurable Utility", *Econometrica*, 21 (1953), 291-297.
- [3] HAMMOND PETER J.: "Changing Tastes and Coherent Dynamic Choice," *Review of Economic Studies*, 43 (1976), 159-173.
- [4] KURATOWSKI, C.: *Topologie*, Vol. 2. Warsaw: Polska Akademia, 1950.
- [5] PARTHASARATHY, K. R.: *Probability Measures on Metric Spaces*. New York: Academic Press, 1967.
- [6] PELEG, B., AND M. E. YAARI: "On the Existence of a Consistent Course of Action when Tastes are Changing," *Review of Economic Studies*, 40 (1973), 391-401.
- [7] RAIFFA, HOWARD: *Decision Analysis*. Reading, Massachusetts: Addison-Wesley Publishing Company, 1968.
- [8] SELDEN, L.: "A New Representation of Preferences over 'Certain \times Uncertain' Consumption Pairs: The 'Ordinal-Certainty Equivalent' Hypothesis," unpublished manuscript, University of Pennsylvania, 1976.
- [9] SPENCE, MICHAEL, AND RICHARD ZECKHAUSER: "The Effect of Timing of Consumption Decisions and the Resolution of Lotteries on the Choice of Lotteries," *Econometrica*, 40 (1972), 401-403.